

innovating to save lives



an affiliate of Johns Hopkins University

# Cervical Cancer Prevention Guidelines for Low-Resource Settings

Jhpiego is an international, non-profit health organization affiliated with The Johns Hopkins University. For nearly 40 years, Jhpiego has empowered front-line health workers by designing and implementing effective, low-cost, hands-on solutions to strengthen the delivery of health care services for women and their families. By putting evidence-based health innovations into everyday practice, Jhpiego works to break down barriers to high-quality health care for the world's most vulnerable populations.

Jhpiego  
Brown's Wharf  
1615 Thames Street  
Baltimore, Maryland 21231-3492, USA  
<http://www.jhpiego.org>

Copyright© 2005 by Jhpiego. All rights reserved. Reprinted in 2007 with updated information. Reprinted 2008.

Authors: Paul D. Blumenthal  
Noel McIntosh

Editors: Sandra Crump  
Sonia Elabd  
Dana Lewison

Production Assistance: Deborah Raynor  
Youngae Kim

ISBN: 0-929817-85-0

TRADEMARKS: All brand names and product names are trademarks or registered trademarks of their respective companies.

Funding provided by the Bill and Melinda Gates Foundation through the Alliance for Cervical Cancer Prevention.

Printed in the United States of America.



innovating to save lives



an affiliate of Johns Hopkins University

# Cervical Cancer Prevention Guidelines for Low-Resource Settings

With funding from the Bill and Melinda Gates Foundation  
through the Alliance for Cervical Cancer Prevention

# TABLE OF CONTENTS

<b>PREFACE AND ACKNOWLEDGMENTS</b> .....	xi
<b>ABBREVIATIONS AND ACRONYMS</b> .....	xii
<b>ONE INTRODUCTION</b>	
Magnitude of the Problem .....	1-1
Background.....	1-1
HIV/AIDS, HPV Infection, and Cervical Cancer.....	1-3
Risk Factors for HPV and Cervical Cancer .....	1-4
Preventing Cervical Cancer .....	1-5
Treatment.....	1-10
Factors Affecting Choice of Treatment .....	1-11
Managing Precancerous Cervical Disease.....	1-13
Treating Women with Unconfirmed Disease .....	1-14
Links to Other Reproductive Health Services .....	1-14
References.....	1-16
<b>TWO HUMAN PAPILLOMAVIRUS AND CERVICAL CANCER</b>	
Background.....	2-1
The Virus .....	2-2
How HPV Induces Cancer.....	2-3
Risk Factors for Cervical Cancer.....	2-4
Preventing Cervical Cancer .....	2-5
Primary Prevention .....	2-6
Secondary Prevention .....	2-8
References.....	2-8
<b>THREE PATHOPHYSIOLOGY OF CERVICAL CANCER</b>	
Background.....	3-1
Key Considerations for Low-Resource Settings.....	3-2
Anatomy and Physiology of the Normal Cervix.....	3-2
Appearance of the Cervix in Normal and Abnormal States .....	3-4
References.....	3-11

## **FOUR TALKING WITH WOMEN ABOUT CERVICAL CANCER**

Background .....	4-1
Client Rights .....	4-2
Confidentiality .....	4-3
Privacy .....	4-3
Who Should Talk with a Woman.....	4-4
Being a Good Counselor.....	4-4
Counseling prior to VIA Testing .....	4-5
Counseling prior to Cryotherapy .....	4-5
Counseling Following Cryotherapy.....	4-6
Questions Frequently Asked by Women .....	4-7
References.....	4-10

## **FIVE PREVENTING INFECTION IN HEALTHCARE WORKERS**

Background.....	5-1
The Disease Transmission Cycle.....	5-2
How Risky Healthcare Work Is.....	5-2
Making Infection Prevention Programs Work.....	5-4
How Healthcare Can Be Made Safer.....	5-4
What to Do if Exposure Occurs.....	5-7
Maintenance of a Safe Environment.....	5-8
References.....	5-8

## **SIX CLIENT ASSESSMENT AND VIA TESTING**

Background.....	6-1
Who Should Be Tested .....	6-1
When to Perform VIA.....	6-2
Client Assessment.....	6-2
Instruments and Supplies .....	6-5
Visual Inspection with Acetic Acid (VIA) .....	6-7
References and Further Reading.....	6-12

## **SEVEN TREATMENT AND FOLLOWUP**

Background .....	7-1
Outpatient Treatment Procedures .....	7-2
Cryotherapy Treatment and Referral .....	7-7
Instruments and Equipment .....	7-10
Cryotherapy Procedure .....	7-13
Routine Followup .....	7-19
References.....	7-20

# APPENDICES

## A TESTS FOR CERVICAL CANCER SCREENING

Automated Pap Smear.....	A-1
Cervicography™.....	A-2
Colposcopy .....	A-3
HPV.....	A-4
Pap Smear .....	A-5
VIA .....	A-6
VIAM.....	A-6
Thin-Layer Pap Smear Preparation (ThinPrep™).....	A-7
VILI.....	A-8

## B SCREENING TEST QUALITIES AND THEIR INTERPRETATION

Commonly Measured Test Qualities .....	B-1
Factors to Consider when Comparing the Quality of Research Test Results.....	B-2
Reference or Gold Standard.....	B-2
Verification or Workup Bias.....	B-3
References.....	B-4

## C INFECTION PREVENTION PROCESSES

Decontamination .....	C-2
Cleaning .....	C-5
High-Level Disinfection .....	C-5
Sterilization .....	C-12
References.....	C-13

## D TECHNICAL OVERVIEW OF THE CRYOTHERAPY SYSTEM

Anatomy of the System.....	D-1
Preparing for Use .....	D-3
The Freeze-Clear-Freeze Technique.....	D-5
Post-Procedure Processing.....	D-6
Storage .....	D-8

## E TROUBLESHOOTING WITH THE CRYOTHERAPY SYSTEM

## F PROCESSING SURGICAL GLOVES

How to Decontaminate and Clean Surgical Gloves before Sterilization or High-Level Disinfection (HLD) .....	F-1
How to Sterilize Surgical Gloves.....	F-2

How to High-Level Disinfect Surgical Gloves by Steaming.....	F-3
References.....	F-5

**G                    PERFORMING BREAST AND PELVIC EXAMINATIONS**

Introduction.....	G-1
Purpose.....	G-1
Before Starting.....	G-2
Tips When Performing Breast and Pelvic Examinations.....	G-2
Getting Ready .....	G-3
Performing a Breast Examination.....	G-3
Breast Self-Examination (BSE).....	G-9
Most Commonly Asked Questions about Breast Examinations.....	G-12
Performing a Pelvic Examination.....	G-14
Lower Abdominal and Groin Examination.....	G-14
External Genital Examination.....	G-17
Speculum Examination .....	G-20
Bimanual Examination.....	G-24
Rectovaginal Examination.....	G-29
Completing the Examination.....	G-31
Most Commonly Asked Questions about Pelvic Examinations.....	G-32
References.....	G-33
Learning Guide for Breast Examinations .....	G-35
Checklist for Breast Examinations .....	G-37
Learning Guide for Pelvic Examinations.....	G-39
Checklist for Pelvic Examinations.....	G-43

**H                    PERCEIVED BARRIERS TO PROVIDING CERVICAL CANCER  
PREVENTION SERVICES**

Barriers and Potential Solutions .....	H-1
Availability of Basic Supplies and Equipment.....	H-3
Summary .....	H-3
Reference .....	H-4

**GLOSSARY**

**ADDITIONAL READING**

## TABLES AND FIGURES

Figure 1-1	Estimated Number of New Cervical Cancer Cases per Year	1-1
Figure 1-2	Natural History of Cervical Cancer—Current Understanding	1-2
Figure 1-3	Incidence of Cervical Cancer, by Age	1-3
Table 1-1	Odds Ratio of CIN among HIV-Positive Women Compared to HIV-Negative Women	1-5
Table 1-2.	Reduction in Cumulative Cervical Cancer Rate with Different Frequencies of Screening	1-7
Table 1-3	Test Qualities of VIA in Primary Healthcare Setting (Phase 2)	1-8
Table 1-4	Test Qualities of VIA when Performed as Primary Screening Method in Low-Resource Settings	1-10
Table 1-5	Advantages and Disadvantages of Cryotherapy and LEEP for Use in Low-Resource Settings	1-12
Table 1-6	Provision of Cervical Cancer Prevention Services (by Level of Healthcare Facility and Staff)	1-16
Figure 2-1	Electron Photomicrograph of Human Papillomavirus	2-2
Table 2-1	Risk Factors for Cervical Cancer	2-4
Figure 3-1	Natural History of Cervical Cancer—Current Understanding	3-1
Figure 3-2	The Cervix at Puberty	3-2
Figure 3-3	The Cervix during the Reproductive Years	3-3
Figure 3-4	The Cervix at Menopause	3-3
Figure 3-5	Normal Cervix	3-8
Figure 3-6	Microanatomy of Dysplasia	3-8
Table 4-1	Expected Side Effects of Cryotherapy	4-6
Figure 4-1	Warning Signs	4-7
Figure 5-1	The Disease Transmission Cycle	5-3

Figure 6-1	Sample Flow Diagram for Cervical Cancer Prevention	6-3
Figure 6-2	Sample Cervical Cancer Prevention Record Form	6-4
Table 6-1	VIA Classification Relative to Clinical Findings	6-7
Figure 6-3	Clinical Significance and Location of Acetowhite Lesions	6-7
Figure 6-4	Possible Links between VIA Testing and Treatment	6-11
Table 7-1	Cervical Cancer Treatment Options	7-1
Table 7-2	Comparison of Treatment Options	7-2
Table 7-3	Cryotherapy for Treatment of CIN: Key Studies with at Least 1 Year of Followup	7-3
Table 7-4	Expected Side Effects of Cryotherapy	7-4
Figure 7-1	LEEP	7-5
Table 7-5	LEEP Success Rates	7-5
Table 7-6	Comparison of Treatment Modalities	7-6
Table 7-7	Recommended Referral Actions	7-8
Figure 7-2	Sample Flow Diagram for Cervical Cancer Prevention	7-9
Figure 7-3	Cryotherapy System	7-11
Figure 7-4	Cryotip and Protective Sleeve	7-12
Figure 7-5	Applying the Cryotip to the Cervix	7-16
Figure 7-6	Freezing Process with Cryotherapy Unit	7-17
Figure 7-7	Warning Signs	7-19
Table 7-8	Treatment Status and Recommended Action	7-20
Figure B-1	Organization of Data to Measure Test Qualities	B-1
Table C-1	Infection Prevention Guidelines for Processing Instruments, Surgical Gloves and Other Items	C-1

Table C-2	Preparing a Dilute Chlorine Solution from Liquid Bleach (Sodium Hypochlorite Solution) for Decontamination and HLD	C-3
Figure C-1	Formula for Making a Dilute Chlorine Solution from Concentrated Solution	C-3
Table C-3	Preparing a Dilute Chlorine Solution from Dry Powder	C-4
Figure C-2	Formula for Making a Dilute Chlorine Solution from Dry Powder	C-4
Figure C-3	Steamer Used for HLD	C-7
Figure C-4	Temperature Rise in Gloves as a Function of Tray Position	C-7
Table C-4	Preparing and Using Chemical Disinfectants	C-9
Figure D-1	Cryotherapy System	2
Figure D-2	Choosing an Appropriate Gas Cylinder	2
Figure D-3	Additional Instructions for Tightening Regulator Fittings	3
Figure D-4	British and US Regulator Fittings	4
Figure D-5	Removing Protector Tube from Probe	5
Figure D-6	Installing Cryotip	5
Figure D-7	Applying Freeze-Clear-Freeze Technique	6
Figure D-8	Removing Cryotip	7
Figure D-9	Placing Protector Tube on Probe	7
Figure D-10	Removing Plastic Sleeve and Inserting Rubber Stopper	7
Figure D-11	Gas Cylinder Secured to Wall	9
Table E-1	Following-Up on Commonly Encountered Problems	E-1
Figure F-1	Preparing Gloves for Autoclaving (Steam Sterilization)	F-2
Table F-1	Tips to Help Avoid Glove Problems	F-3
Figure F-2	Gloves in Steamer Pan	F-4
Figure G-1	Appearance of Breasts (Hands at Sides)	G-4

Figure G-2	Breast Puckering or Dimpling	G-5
Figure G-3	Appearance of Breasts (Left to Right): Arms over Head, Hands on Hips, Leaning Forward	G-5
Figure G-4	Spiral Technique of Breast Examination	G-6
Figure G-5	Checking for Nipple Discharge (Left Breast)	G-7
Figure G-6	Checking the Axilla (Left Breast)	G-7
Figure G-7	Breast Self-Examination	G-11
Figure G-8	Average Size of Lumps Detected	G-13
Figure G-9	Palpating the Abdomen	G-15
Figure G-10	Woman Positioned for Pelvic Examination on Table with Stirrups	G-17
Figure G-11	Woman Positioned for Pelvic Examination on Table without Stirrups	G-17
Figure G-12	External Genitalia	G-18
Figure G-13	Checking the Skene's Glands	G-19
Figure G-14	Checking the Bartholin's Glands	G-20
Figure G-15	Inserting the Speculum	G-21
Figure G-16	Rotating the Speculum	G-22
Figure G-17	Opening the Speculum Blades	G-22
Figure G-18	Speculum in Place with Blades Open	G-23
Figure G-19	Removing the Speculum	G-24
Figure G-20	Inserting the Fingers into the Vagina	G-25
Figure G-21	Checking Cervical Movement	G-26
Figure G-22	Palpation of an Anteriorly Directed Uterus	G-26
Figure G-23	Feeling a Retroverted Uterus	G-27
Figure G-24	Locating the Ovary	G-28
Figure G-25	Performing a Rectovaginal Examination	G-30

# PREFACE AND ACKNOWLEDGMENTS

This reference manual is designed for use by trainers and healthcare providers who are embarking on a cervical cancer prevention program that will focus on visual inspection with acetic acid (VIA) and/or cryotherapy as the core programmatic elements.

The information and guidelines contained in this manual were derived from a variety of sources, including field experiences, results of both published and unpublished scientific works and input from many expert reviewers. Moreover, the specific concepts, principles and procedural recommendations provided in this manual have been extensively and successfully used in a variety of field settings, most notably in El Salvador, Ghana, Malawi, Peru, the Philippines, Thailand, and Zimbabwe, as part of either training, research or service delivery projects.

The material is arranged both according to established principles of medical education (epidemiology, pathophysiology, clinical intervention) and according to the order in which knowledge and skills might be gradually acquired during training. The general approach of competency-based training described in the manual has been used extensively in a wide variety of settings worldwide.

Although this manual could be used alone in training in providing VIA and cryotherapy services, it is intended to be used as an integral part of a comprehensive learning package that includes a handbook for participants, a trainer's guide, an interactive CD-ROM of cervical images, a set of flash cards containing cervical images and questions, an "atlas" of cervical images, a companion manual on performance support, and anatomic models.

We wish to acknowledge the contributions of the many colleagues and collaborators who played a part in the development of this manual as reviewers and trainers. Because of their assistance and persistence, the manual is a much better resource than it would otherwise have been. They include: Ann Blouse, Dr. Khunying Kobchitt Limpaphayom, Dr. Pisake Lumbiganon, Dr. Somkeart Srisupundit, Dr. Bundit Chumworathayee, Dr. Sunguanchoke Luanrattanakorn, Dr. Suwaree Paojirasinchai, Dr. Sumontha Prasertpan, Dr. Choochai Tamthanakitphisan, Dr. Tinnakorn Sirasapoom, Dr. Wachara Eamratsameekool, Dr. Samrat Podapol, Dr. Sydney Adadevoh, Dr. Sylvia Deganus, Saifuddin Ahmed, Dr. Margo Lauterbach, Dr. Ricky Lu, Mark Fritzler, Karen Mazziott, Sara Slade, and Sapna Sharma. A special thanks goes to Dr. Fredrik Broekhuizen whose dedication to detail and consistency improved the document immensely.

## ABBREVIATIONS AND ACRONYMS

AAT	Acetic acid test
ACCP	Alliance for Cervical Cancer Prevention
AIDS	Acquired immunodeficiency syndrome
ARV	Antiretroviral
ASCUS	Atypical cells of uncertain significance
CDC	The US Centers for Disease Control and Prevention
CIN	Cervical intraepithelial neoplasia
CIS	Carcinoma <i>in situ</i>
DHLY	Discounted health life year
FCF	Freeze-clear-freeze
HAART	Highly active antiretroviral therapies
HBV	Hepatitis B virus
HGSIL	High-grade squamous intraepithelial lesion
HIV	Human immunodeficiency virus
HLD	High-level disinfection
HPV	Human papillomavirus
IARC	International Agency for Research on Cancer
LEEP	Loop electrosurgical excision procedure
LGSIL	Low-grade squamous intraepithelial lesion
Pap smear	Papanicolaou smear
PLWHA	People living with HIV/AIDS
ROC	Receiver operating characteristic
SCJ	Squamocolumnar junction
SIL	Squamous intraepithelial lesion
STI	Sexually transmitted infection
T-zone	Transformation zone
UNAIDS	The Joint United Nations Programme on HIV/AIDS
US	United States
VIA	Visual inspection with acetic acid
VIAM	Visual inspection with acetic acid and magnification
WHO	World Health Organization

## ONE

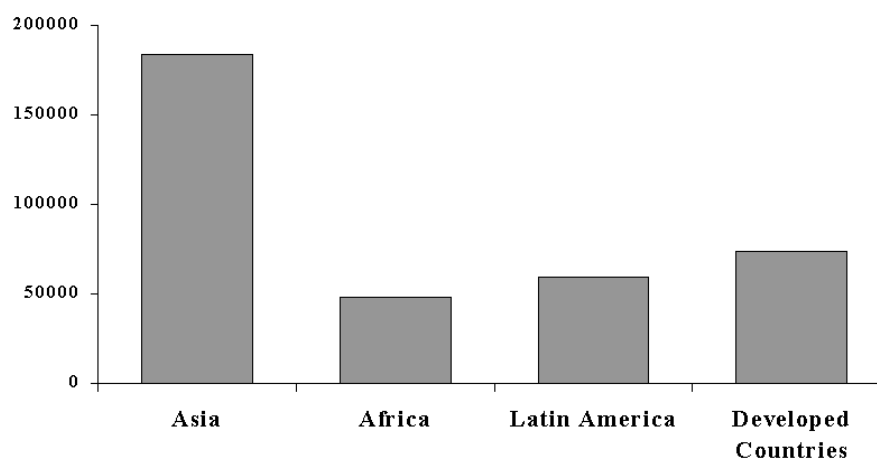
# INTRODUCTION

### MAGNITUDE OF THE PROBLEM

Cervical cancer is an important health problem for women throughout the world. It is the third most common cancer in women—affecting more than 1.4 million women worldwide (Ferlay et al. 2001). Each year, more than 460,000 new cases occur and about 231,000 women die of the disease (Parkin 2000; Sherris and Herdman 2000).

As shown in **Figure 1-1**, cervical cancer is a particularly significant problem in developing countries, where about 80% of new cervical cancer cases occur every year.

**Figure 1-1. Estimated Number of New Cervical Cancer Cases per Year**



Source: Parkin 2000.

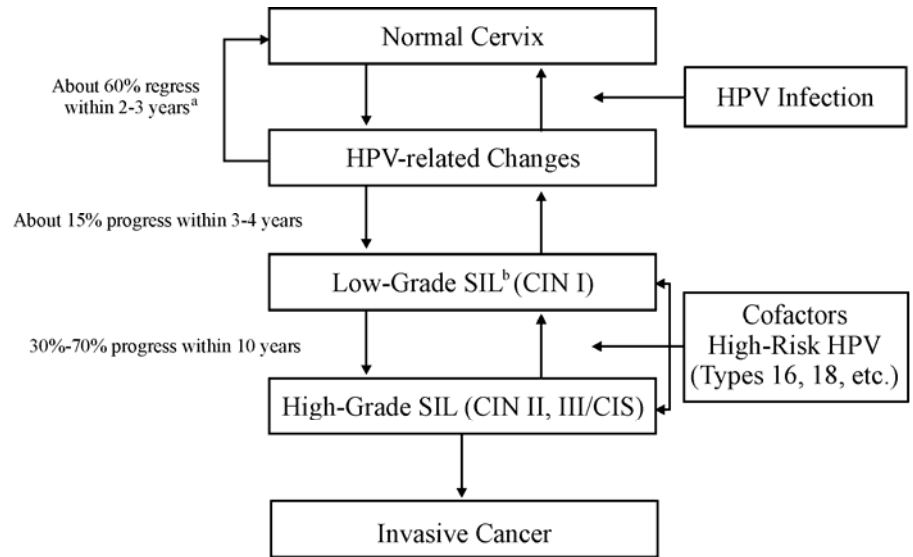
### BACKGROUND

Nearly all (99.7%) cervical cancers are directly linked to previous infection with one or more types of human papillomavirus (HPV), one of the most prevalent sexually transmitted infections in the world (Judson 1992; Walboomers et al. 1999). Of the more than 50 types of HPV that infect the genital tract, 15 to 20 types are linked to cervical cancer. Four of those types—16, 18, 31, and 45—are most often detected in cervical cancer cases, and type 16 accounts for half of the cases worldwide (Bosch et al. 1995).

HPV infections often do not cause symptoms. The most common signs of infection are small pink or red warts that appear in the genital area and

itching or burning in the genital area. After a woman becomes infected with HPV, the infection may remain locally stable, may regress spontaneously, or if the cervix is affected, may develop into low-grade squamous intraepithelial lesions (LGSILs), which are also called mild cervical intraepithelial neoplasia (CIN I) or early dysplasia. Most low-grade (CIN I) lesions disappear without treatment or do not progress, particularly those that occur in younger women (**Figure 1-2**). It is estimated that for every 1 million women infected, 10% (about 100,000) will develop precancerous changes in their cervical tissue. These precancerous changes are observed most frequently in women between ages 30 and 40.

**Figure 1-2. Natural History of Cervical Cancer—Current Understanding**



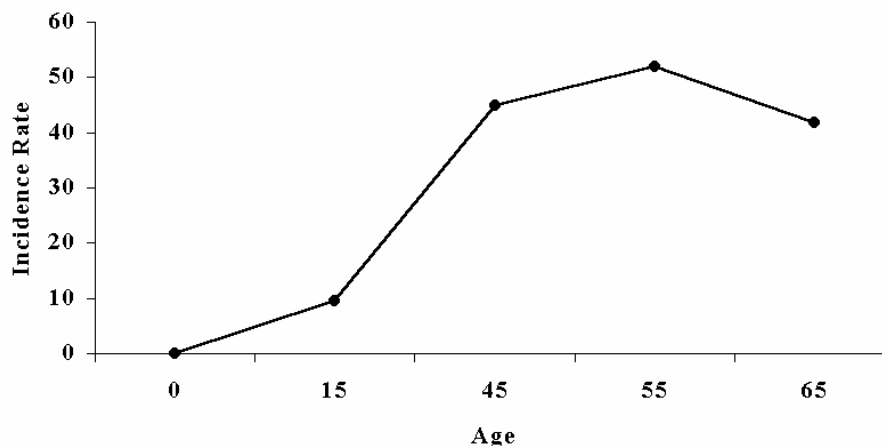
<sup>a</sup> Prevalent cases will have a lower regression rate.

<sup>b</sup> For definitions of SIL, CIN and CIS, see Glossary. For an illustration of the cellular changes with each, see page 3-8.

Source: PATH 1997.

About 8% of the women who develop these changes will develop pre-cancer limited to the outer layers of the cervical cells (carcinoma *in situ* [CIS]), and about 1.6% will develop invasive cancer unless the precancerous lesion or CIS is detected and treated. Progression to cervical cancer from high-grade squamous intraepithelial lesions (HGSILs) generally takes place over a period of 10 to 20 years (**Figure 1-3**). Although rare, some precancer lesions become cancerous over a shorter time interval—within a year or two (Hildesheim et al. 1999).

Although HPV-related lesions (e.g., warts) can be treated, currently there is no cure for HPV infection. Once infected, a person is most likely infected for life. In most cases, an active infection is controlled by the immune system and becomes dormant over time. It is not possible, however, to predict whether or when the virus will become active again.

**Figure 1-3. Incidence of Cervical Cancer, by Age**

Source: Ferlay et al. 2001.

## HIV/AIDS, HPV INFECTION, AND CERVICAL CANCER

Globally, the HIV epidemic continues to take its toll on men and women. The Joint United Nations Programme on HIV/AIDS (UNAIDS) estimates that 39.5 million people were living with HIV/AIDS (PLWHA) in 2006, and almost half of the adults (48%) afflicted with the disease are women (UNAIDS 2006). Heterosexual contact is the essential mode of HIV transmission in an increasing number of new cases. Its confluence with HPV infection, one of the most common STIs, affects the natural history of HPV and its associated diseases. A number of studies have consistently shown that in HIV-seropositive women, HPV infection is detected more frequently and tends to resolve with more difficulty than in HIV-seronegative women—and HPV-associated diseases including genital warts, dysplasias and squamous cell cancers are more difficult to treat (Moscicki and Jay 2000). A 2000 study highlighted the importance of screening programs after finding that one in five HIV-infected women developed dysplasias within three years (Ellerbrock TV et al. 2000). According to a recent World Health Organization (WHO) publication, in areas where HIV is endemic, cervical cancer screening results may be positive for precancerous lesions in up to 15–20% of the target population (WHO 2006).

In 1993, the US Centers for Disease Control and Prevention (CDC) included cervical squamous cell cancer in the expanded definition of an AIDS-defining illness (CDC 1992). Antiretroviral (ARV) treatment has improved the quality of life of PLWHAs, allowing them to live longer. Where there is increased access to effective ARVs, high-quality reproductive health care becomes ever more important—including screening for cervical cancer. While it is known that HIV accelerates the progression of precancerous lesions, the effect of highly active antiretroviral therapies (HAART) on this progression is not yet clear.

WHO generally recommends that women should be offered the same cervical cancer screening options irrespective of their HIV status.

## **RISK FACTORS FOR HPV AND CERVICAL CANCER**

Epidemiologic studies have identified a number of factors that play a significant role in the development of CIN (Palank 1998). The risk factors for HPV acquisition and cervical cancer include the following:

- Sexual activity before age 20
- Multiple sexual partners
- Exposure to sexually transmitted infection (STI)
- Mother or sister with cervical cancer
- Previous abnormal Papanicolaou (Pap) smear
- Smoking
- Immunosuppression:
  - HIV/AIDS
  - Chronic corticosteroid use

The type and pattern of sexual activity, especially in adolescents, are major factors in determining whether a person becomes infected with HPV. The number of sexual partners that adolescents have before age 20 may be quite large, and each of their partners also may have had multiple partners. As a result, this pattern of sexual activity increases the risk of exposure to STIs, especially HPV.

Another risk factor is having a blood relative (mother or sister) with cervical cancer. Magnusson, Sparen and Gyllensten (1999) compared the incidence of dysplasia and CIS in relatives of women with disease and in age-matched controls. They found a significant familial clustering among biological, but not adoptive, relatives. For biological mothers the relative risk was 1.8, whereas for adoptive mothers the relative risk was 1.1 (relative risk for controls was 1). For biological full sisters the relative risk was even higher (1.9), whereas it was 1.1 for nonbiological sisters. These data provide strong epidemiological evidence of a genetic link to the development of cervical cancer and its precursors.

Suppression of the immune system (e.g., HIV/AIDS infection) also is an important risk factor because it makes the cells lining the lower genital tract (vulva, vagina and cervix) more easily infected by the cancer-inducing types of HPV (Stentella et al. 1998). There is substantial evidence that HIV-positive women are at increased risk of developing precancerous lesions (Judson 1992). In two studies, both from high HIV

prevalence areas, a statistically significant association between HIV and CIN was reported (**Table 1-1**). Because the number of adolescents, as well as adults, with HIV is rising in most countries where cervical cancer is largely untreated, cervical cancer rates are expected to continue increasing.

**Table 1-1. Odds Ratio\* of CIN Among HIV-Positive Women Compared to HIV-Negative Women**

AUTHOR	COUNTRY	DATE	ODDS RATIO
Miotti et al.	Malawi	1996	2.2 (1.10–4.8)
Maggwa et al.	Kenya	1993	2.69 (1.29–5.49)

\* Compares likelihood of CIN occurring in HIV-positive group with likelihood in HIV-negative group.

Other less common conditions that cause immunosuppression include those requiring chronic corticosteroid treatment, such as asthma or lupus (McDonald 1999). Women also increase their risk for CIN by engaging in other behaviors that are known to suppress the immune system, such as use of recreational drugs, alcohol and cigarettes. Nicotine and the byproducts of smoking are thought to increase a woman's relative risk for cervical cancer by concentrating in the cervical mucus and decreasing the immune capability of Langerhan's cells to protect cervical tissue from invading oncogenic factors, such as HPV infection (Ylitalo et al. 1999).

## PREVENTING CERVICAL CANCER

**Primary Prevention** Preventing HPV infection will prevent cervical cancer. This primary prevention approach, however, presents greater challenges than for most other STIs. Although condoms significantly reduce the risk of infection of HIV, there is no conclusive evidence that condoms reduce the risk of HPV infection. Studies have suggested, however, that condoms may provide some protection against HPV-associated diseases, including cervical neoplasia (NIAID 2001).

The most effective way to prevent cervical cancer would be to develop a vaccine against HPV. The benefits of such a vaccine would be particularly significant in developing countries, where women's healthcare services are minimal or severely limited. A vaccine, however, would protect a person against only some types of HPV. There may be subtypes within these virus types that would not be prevented by the vaccine. In addition, the types of HPV associated with cervical disease vary by geographical area. Therefore, a vaccine against HPV would need to contain a mixture of several virus types (Groopman 1999; Stewart et al. 1996).

## *Introduction*

Despite these problems, at least two vaccines are available that can protect women from cancer-linked papillomaviruses (HPV types 16 and 18): bivalent (Cervarix®) and quadrivalent (Gardasil®) vaccines. Both are considered prophylactic vaccines and preferably given prior to natural exposure to HPV types 16 and 18 (Wright et al. 2006). It will most likely be several years, however, before either vaccine will be affordable in developing countries. There have also been attempts to produce a therapeutic vaccine, which would boost the immune system of someone who is already infected and cause the cancer to regress or even disappear. This vaccine is targeted to inactivate the E6 and E7 proteins, those viral proteins that block the action of the cell growth regulating proteins (Rb and p53) (Massimi and Banks 1997).

Until a protective vaccine is widely available, primary prevention must focus on reducing the behaviors and risks that increase a person's risk of becoming infected. Risk reduction counseling related to the risk factors listed above should be incorporated into all levels of the healthcare system, especially those dealing with young people, and should inform adolescents that practices designed to minimize the risk of STI or HIV exposure (e.g., the use of male or female condoms) may not be as effective for HPV prevention. In addition, vigorous efforts to discourage adolescents, especially young girls, from starting smoking and initiating sexual activity should be widely and continually disseminated.

## **Secondary Prevention**

Women who are already infected with HPV should be screened to determine whether they have early, easily treatable precancerous lesions (i.e., screening). If lesions are found, they should be treated before they progress to cancer. Although the Pap smear is the most well-established method of screening women for precancerous lesions, other approaches to screening women at risk for cervical cancer have been investigated. These include visual screening, HPV tests and automated cytology screening. **Appendix A** lists a number of cervical cancer screening tests and their technical components, benefits and limitations.

## **Screening**

For screening programs to have an impact on the incidence of cervical cancer, they need to screen as many women as possible. Ideally, the programs would screen 80% of the population at risk. Then, those women who are identified as having precancerous lesions need to have those lesions treated before they progress to cancer. When coverage is high, it is not necessary to screen women annually to have an impact on disease incidence. For example, if all women ages 35–64 who have had one negative Pap smear were to be screened every 5 years (and all those with dysplasia treated), the estimated incidence of cervical cancer could be reduced by about 84% (**Table 1-2**). Screening these women even every 10 years would reduce the incidence by an estimated 64%.

**Table 1-2. Reduction in Cumulative Cervical Cancer Rate with Different Frequencies of Screening**

FREQUENCY OF SCREENING* IN YEARS	REDUCTION (%) IN CUMULATIVE RATE
1	93.5
2	92.5
3	90.8
5	83.6
10	64.1

\* Screening all women age 35–64 who have had at least one previous negative Pap smear.

Source: IARC 1986.

Rates of cervical cancer are higher in developing countries in part because those countries lack effective screening programs. Because the majority of cervical cancer cases occur among women in developing countries, screening methods need to be both effective at detecting precancerous changes and feasible in settings with limited resources. Pap smear-based programs have been difficult to establish and maintain in many developing countries because they involve many complex and costly steps. Pap smear or cytology-based screening may seem relatively simple, but it involves taking an adequate smear, having the necessary equipment and supplies, processing and analyzing the specimen, and communicating the information back to the woman so appropriate next steps can be agreed upon. If any of these steps are unreliable or logistically burdensome, the entire prevention program can fail and, with it, the potential for any public health benefit (Gaffikin et al. 1997). Many, if not all, of these steps can be problematic in low-resource settings. For example, in a number of countries, Pap smears are offered only in urban areas by a small private sector facility or at referral facilities. And, even in these settings, trained cytotechnicians and cytopathologists are scarce, and turnaround times for processing and analyzing specimens can be long. Because women do not receive their results promptly, many do not return to the clinic for their results and become lost to followup.

Recent data indicate that visual inspection of the cervix using acetic acid (VIA) is at least as effective as Pap smears in detecting disease and may be associated with fewer logistic and technical constraints. In 1994, a study was conducted in South Africa in which VIA and Pap smears were performed in a mobile unit that was equipped to process smears on site (Megevand et al. 1996). In this study, either immediately after or within a few days of screening, a gynecologist performed colposcopy to confirm disease. The positive predictive value for VIA was found to be similar to that of Pap smears, and the authors concluded that “naked-eye visualization of the cervix after application of diluted acetic acid... warrants consideration as an alternative to cytologic screening.”

Three studies conducted in India during the late 1990s provided additional evidence that VIA is a viable alternative to Pap smear as a primary screening test. In a study by Londhe, George and Seshadri, 372 women underwent VIA, Pap smear and colposcopy in a gynecology outpatient clinic. VIA identified high-grade (CIN I-II) lesions in 78% of the women diagnosed with high-grade lesions using colposcopy—3.5 times more women than were identified using Pap smear. The authors concluded that “the advantage of the acetic acid test lies in its easy technique, low cost and high sensitivity which are important factors for determining the efficacy of any screening program in developing countries.”

In another study in India involving approximately 3,000 women, VIA and Pap smears performed by cytotechnicians demonstrated very similar performance (sensitivity ratio of 1.05) in detecting moderate or severe dysplasia (Sankaranarayanan et al. 1998). The approximate specificity of VIA in this study was 92.2%, compared to 91.3% for Pap smears. In another study (Sankaranarayanan et al. 1999), in which nurses were trained to perform VIA and Pap smears, VIA had a significantly higher rate than Pap smears of detecting more moderate or severe lesions. VIA was, however, significantly less specific than Pap smears. The authors concluded that “the non-invasive nature and easy applicability of the test coupled with immediate availability of results...makes VIA an attractive screening test.”

In 1999, a study of more than 10,000 women in Zimbabwe addressed the question of whether VIA can effectively distinguish diseased from nondiseased cervixes. In Phase 2 of this study, in which direct test quality estimates were calculated, the reported sensitivity of VIA (77%) was higher than that of the Pap smear, whereas the specificity (64%) was lower (University of Zimbabwe/JHPIEGO Cervical Cancer Project 1999) (**Table 1-3**).

**Table 1-3. Test Qualities of VIA in Primary Healthcare Setting (Phase 2)**

TEST	SENSITIVITY (%)*	SPECIFICITY (%)*	POSITIVE PREDICTIVE VALUE (%)*	NEGATIVE PREDICTIVE VALUE (%)*
VIA (n = 2,130)	77 (70–82)	64 (62–66)	19	96
Pap smear (n = 2,092)	44 (35–51)	91 (37–51)	33	94

\* 95% Confidence Interval

Source: University of Zimbabwe/JHPIEGO Cervical Cancer Project 1999.

An important finding from the Zimbabwe study was that nurse-midwives quickly learned to perform VIA in a primary healthcare setting and could correctly identify women with no disease, those suitable for immediate treatment and those requiring referral for advanced disease. The key to

their performance was training. During a week-long, competency-based training course, participants used a specially designed VIA cervical atlas and practiced VIA on pelvic models before working with patients. During the first few months of the project, the nurse-midwives also received supplemental training in the work setting.

Since these initial studies were conducted and their results published, a large group of subsequent studies has been conducted, many of these building on the information and design innovations that were present in the studies mentioned above. A summary article of evidence to date cited multiple studies that report the test qualities of VIA (Gaffikin, 2003). It was suggested that VIA is comparable to the Pap test as a cervical cancer screening tool. A large study by Denny et al. (2002) “confirmed the utility of DVI [direct visual inspection of the cervix after the application of 5% acetic acid] as a primary screening test.” Similarly, the results of a study by Rodriguez-Reyes et al. (2002) revealed a high sensitivity and negative predictive value for CIN I and CIN II using the acetic acid test (AAT). Gaffikin et al. (2003) furthermore emphasized the research that supports the potential usefulness of VIA in low-resource settings. In their study, Singh et al. (2001) also concluded “screening for cervical precancerous and cancerous lesions using visual inspection aided by acetic acid may be a suitable low-cost and a feasible alternative modality for control of cervical cancer in a resource poor setting.” Further, as a result of all of these studies, a variety of professional organizations—including the American College of Obstetricians and Gynecologists, the Royal College of Obstetricians and Gynaecologists, the Canadian Society of Obstetricians and Gynecologists and the International Federation of Gynecology and Obstetrics (FIGO)—have all endorsed VIA as a viable option for screening in low-resource settings (ACOG 2004).

**Table 1-4** summarizes the results of a number of VIA test quality studies performed to date that confirm the usefulness of VIA as a screening tool in low-resource settings. Based on the results of these studies, VIA has been characterized as a proven, simple alternative for identifying women with precancerous cervical lesions (Kitchener and Symonds 1999; Parkin and Sankaranarayanan 1999; Sankaranarayanan, Budukh and Rajkumar 2001).

**Table 1-4. Test Qualities of VIA when Performed as Primary Screening Method in Low-Resource Settings**

STUDY	COUNTRY	NUMBER OF CASES	DETECTION OF HGSIL <sup>a</sup> AND CANCER	
			SENSITIVITY <sup>b</sup>	SPECIFICITY <sup>b</sup>
Belinson (2001)	China	1,997	71%	74%
Denny et al. (2000)	South Africa	2,944	67%	84%
Sankaranarayanan et al. (1999)	India	1,351	96%	68%
University of Zimbabwe/JHPIEGO (1999)	Zimbabwe	2,148	77%	64%
Sankaranarayanan et al. (1998)	India	2,935	90%	92%
Megevand et al. (1996)	South Africa	2,426	65%	98%
Sankaranarayanan and Wesley (unpublished)	India	2,462	84%	90%
Sankaranarayanan et al. (2004)	India	56,939	76.8%	85.5%

<sup>a</sup> HGSIL = high-grade squamous intraepithelial lesion

<sup>b</sup> Estimated from the number provided in the manuscript and does not reflect adjustment(s) for verification bias.

*Adapted from:* Belinson et al. (2001); Denny et al. (2000); Megevand et al. (1996); Sankaranarayanan et al. (1999); Sankaranarayanan et al. (1998); Sankaranarayanan and Wesley (unpublished); and University of Zimbabwe/JHPIEGO Cervical Cancer Project (1999).

**In summary**, VIA can be considered for use in low-resource settings because it:

- Can effectively identify most precancerous lesions
- Is noninvasive, easy to perform and inexpensive
- Can be performed by all levels of healthcare workers in almost any setting
- Provides immediate results that can be used to inform decisions and actions regarding treatment
- Requires supplies and equipment that are readily available locally

## TREATMENT

In order for cervical cancer prevention programs to be truly effective and of public health value, testing should be linked to appropriate treatment for any precancerous lesions detected.

### What Lesions Need to Be Treated?

There is clear consensus that high-grade (CIN II–III) lesions should be treated because they are more likely than low-grade lesions (CIN I) to progress to cancer. Published studies indicate that most low-grade lesions will regress spontaneously and thus do not require treatment. When close followup or histological confirmation is not feasible or possible, treatment of acetowhite lesions (which could be low-grade or high-grade

lesions, or a false positive) may be advisable, particularly if the treatment is not highly invasive or associated with serious side effects, complications or long-term sequelae.

## **FACTORS AFFECTING CHOICE OF TREATMENT**

Because precancerous lesions of the cervix occur most frequently in women who are still in their childbearing years—30s and 40s—it is important to recognize and consider the method’s effect on fertility as well as its safety in pregnancy. Other factors to be considered include the following:

- Method effectiveness
- Safety and potential side effects
- Who is allowed (or legally able) to provide treatment, and what training they need to become qualified to provide it
- The size, extent, severity and site of the lesion
- Acceptability (to women) of treatment offered
- Equipment and supplies required
- Availability of method
- Cost or affordability of method

### **Inpatient Versus Outpatient Treatment**

In developed countries, treatment of a precancerous cervical condition has changed from an inpatient surgical procedure (e.g., cone biopsy and hysterectomy) to simpler, safer outpatient procedures, such as cryotherapy, laser vaporization, electrosurgery and loop electrosurgical excision procedure (LEEP). Inpatient procedures are associated with serious complications, such as hemorrhage and infection. In addition, these procedures are expensive and require anesthesia, operating rooms and hospital beds.

Over the years, there has been much discussion about which outpatient method is best in terms of safety, efficacy and cost. Outpatient methods can be used either to destroy tissue (cryotherapy, laser vaporization or electrosurgery) or remove it (LEEP). Cryotherapy, which freezes cells using a liquid coolant (compressed carbon dioxide or nitrous oxide gas), is very effective in treating high-grade (CIN II–III) lesions, has a low rate of complications, does not require electricity, and is easy to use and inexpensive. These factors make cryotherapy most suitable for low-resource settings compared to other outpatient methods. Cryotherapy, however, does not provide a tissue specimen for histologic examination. During LEEP, a portion of or the entire squamocolumnar junction (SCJ) is removed, thereby providing a surgical specimen and reducing the possibility of missing invasive cancer. In many low-resource settings, however, the facilities, equipment and personnel necessary to perform histologic evaluation often

are not available. Because LEEP requires more equipment and has more potentially serious complications than cryotherapy, it may be best suited to facilities where medical backup is available.

There are some differences in effectiveness rates between cryotherapy and LEEP, especially when lesion size is large. A recent randomized clinical trial, however, showed that, overall, the differences were not statistically significant (Mitchell et al. 1998). This study also demonstrated that LEEP had a higher rate of complication (8%) than cryotherapy (2%). Although these differences were not statistically significant, the main difference in complications among the procedures was the higher risk of postoperative bleeding with LEEP (3%) versus cryotherapy (0%). In this study, less than 1% of women developed cervical stenosis or pelvic infection regardless of the type of procedure used. **Table 1-5** summarizes the advantages and disadvantages of cryotherapy and LEEP when used in low-resource settings.

**Table 1-5. Advantages and Disadvantages of Cryotherapy and LEEP for Use in Low-Resource Settings**

TREATMENT	ADVANTAGES	DISADVANTAGES
<b>Cryotherapy</b>	<ul style="list-style-type: none"> <li>● Effective with mild and moderate lesions (85–95% cure rate)</li> <li>● Inexpensive</li> <li>● Nonphysician can perform</li> <li>● No local anesthesia required</li> <li>● No electricity required</li> <li>● Associated with few complications/side effects</li> <li>● Can be performed during pregnancy</li> </ul>	<ul style="list-style-type: none"> <li>● Variable success rate with large, severe lesions (70–90% cure rate)</li> <li>● Destructive (leaves no tissue sample for confirmatory diagnosis)</li> <li>● Difficult to determine exact amount of tissue destroyed</li> <li>● Associated with profuse watery discharge for 4–6 weeks following treatment</li> <li>● Requires access to and resupply of coolant (CO<sub>2</sub> or N<sub>2</sub>O)</li> </ul>
<b>LEEP</b>	<ul style="list-style-type: none"> <li>● Effective (90–96% cure rate)</li> <li>● Enables tissue sampling for diagnosis</li> <li>● Associated with few complications/side effects</li> </ul>	<ul style="list-style-type: none"> <li>● More expensive than cryotherapy</li> <li>● Primary side effect is peri-operative bleeding (3–8%)</li> <li>● Physician required to perform</li> <li>● Requires local anesthesia</li> <li>● Requires electricity (but could be battery powered)</li> <li>● Requires resupply of loops</li> <li>● Should not be performed during pregnancy</li> </ul>

Compared to other methods of treatment, it is relatively easy to train different cadres of healthcare providers to use cryotherapy (Blumenthal et al. 2005). This advantage, combined with its low cost and high efficacy rate, make it appropriate for low-resource settings where only nurses or nurse-midwives are posted.

## **MANAGING PRECANCEROUS CERVICAL DISEASE**

In developed countries, to reduce the number of times a woman needs to visit the clinic, many screening programs have adopted a “see-and-treat” approach to managing precancerous cervical lesions. A screen-and-treat approach means that after receiving a positive Pap smear result, a woman has a colposcopic examination and, if colposcopically indicated, is immediately offered treatment with LEEP without waiting for histologic confirmation.

The management approach described in this manual uses a modified version of the screen-and-treat approach. This “single visit” approach links VIA with treatment using cryotherapy. Using this approach, women with VIA-positive results and for whom cryotherapy is indicated are offered treatment. The main advantage of this approach is that it reduces the number of women who are lost to followup. This loss often occurs when women have to return to the clinic for the screening test results, diagnostic followup and possible treatment.

In addition, performing VIA and cryotherapy during the same visit can occur at the lowest level of the healthcare system, where the majority of at-risk women will go at least once in their lives. Given that the healthcare providers most often posted to such low-level facilities are nurses or nurse-midwives, this approach assumes that both testing and treatment can be performed competently by these or similar cadres of healthcare personnel. The disadvantage of the screen-and-treat approach is that because VIA has a considerable false-positive rate, a proportion of women who are VIA-positive do not have precancerous lesions. The lower the prevalence of disease in the population being screened, the higher the number of women with false positive results who may agree to receiving treatment immediately after VIA.

As of 2004, there is now one study with published results from a project using the single visit approach in conjunction with VIA.

## **TREATING WOMEN WITH UNCONFIRMED DISEASE**

In studies conducted to date in relatively high prevalence areas, the positive predictive value of VIA has been between 10% and 35%. This means, using a single visit or screen-and-treat approach, that between 6.5 to 9 of every 10 women in similar populations who test positive on VIA do not have a high-grade (CIN II–III) lesion and would be offered immediate treatment (Sankaranarayanan 2001). Because of the low morbidity reported in published studies associated with cryotherapy, however, treatment with cryotherapy of all women with a VIA-positive result may be cost-effective because of the likelihood of preventing the disease from progressing to cervical cancer (Goldie et al. 2001; Mandelblatt et al. 2001). In settings where women are not likely to return for any followup after testing, some degree of over-treatment may be necessary in order to provide treatment to those who have disease that is more likely to progress to cancer (Lonky et al. 1997).

While over-treatment of some women may translate into extra costs to the healthcare system as well as the unnecessary discomfort and potential side effects for women with false-positive results, most women are unlikely to have the opportunity to have a diagnostic test confirming their true disease state. In such an environment, offering to treat suspicious precancerous lesions, which in actuality represent either no disease, low-grade (CIN I) lesions or high-grade (CIN II–III) lesions, also could be considered a *preventive* measure against developing of cervical cancer. This is because cryotherapy has the potential to significantly reduce the probability of developing cancer or precancerous lesions (Lonky et al. 1997). In many low-resource settings, it is standard practice to use cryotherapy or electrocautery to treat chronic cervicitis. In such instances, either procedure resolves cervicitis and possibly reduces cervical ectopy, which could have a long-term protective effect against HPV and HIV. Finally, recurrences of disease after cryotherapy are more likely to involve one or more types of HPV other than the type present at the time of treatment. By contrast, recurrences seen after excisional treatment (e.g., LEEP) tend to be of the same type (Nuovo, Banbury and Calayag 1991). Thus, if a woman who is VIA-positive is infected by one of the high-risk HPV types and is treated by cryotherapy, this treatment could eliminate her existing oncogenic HPV type and possibly prevent her from ever developing a precancerous lesion.

## **LINKS TO OTHER REPRODUCTIVE HEALTH SERVICES**

Linking cervical cancer screening and treatment services with other reproductive health services is essential and logical. Yet these services are completely separate in much of the world. This separation leaves women without access to reproductive healthcare and contributes

significantly to women's poor overall health status. The integration of cervical cancer prevention with existing reproductive health services clearly answers the call to make cervical cancer prevention "accessible through the primary healthcare system, to all individuals of appropriate ages as soon as possible" (ICPD 1994). Testing, treatment and the necessary followup care for gynecological cancers are considered an integral part of reproductive health by a range of international organizations and were included in the Cairo Programme of Action (Jones 1999).

**Table 1-6** provides information on the cervical cancer screening and treatment services that are appropriate at different healthcare facility levels and highlights the need for community involvement to promote awareness of cervical cancer prevention. There is now general agreement that the interventions needed to save the lives and preserve the health of women must be part of a broad strategy to improve reproductive health. This strategy implies that interventions should be applied holistically within a general health context that promotes equity in access to and quality of care. Finally, in order to make the best use of existing resources, these essential services should be integrated into and operate through the existing primary healthcare systems.

As shown in **Table 1-6**, the district-level health system is the basic unit in developing countries for planning and implementing the interventions outlined in this manual. The district provides a mechanism for linking families and communities with health centers and hospitals in a functional, cost-effective manner. Through district-based implementation of interventions, it is possible to ensure that health services are available as close as possible to people's homes. Treatment procedures for precancerous disease of the cervix should be carried out by the healthcare worker who is closest to the community and competent to perform them safely and effectively. The person best equipped to provide community-based, technologically appropriate, safe and cost-effective care to women during their reproductive lives is usually the nurse or midwife who works in the community near the women she serves. She can ensure that the healthcare system serves women fairly and effectively and that the health services available respond to the needs of the people.

More information concerning programmatic aspects related to starting and managing a cervical cancer prevention program can be found in *Planning and Implementing Cervical Cancer Prevention and Control Programs: A Manual for Managers*, published in 2005 by the Alliance for Cervical Cancer Prevention.

Table 1-6. Provision of Cervical Cancer Prevention Services (by Level of Healthcare Facility and Staff)

LEVEL	STAFF MAY INCLUDE	SERVICES	REQUIREMENTS
<b>Community</b>	<ul style="list-style-type: none"> <li>Community leaders<sup>a</sup></li> <li>Women's groups</li> <li>Community health workers</li> </ul>	<ul style="list-style-type: none"> <li>Recognition of importance of cervical cancer</li> <li>Referral to facilities where screening is available</li> <li>Palliative (supportive) care</li> </ul>	<p>Community mobilization</p> <p>Information, education, and communication: radio messages, pamphlets, and other public information</p> <p>Training and access to necessary supplies</p>
<b>Primary Level<sup>b</sup></b> <b>(Primary Health, Family Planning or Polyclinics)</b>	Nurses, midwives or physician assistants	<p>Above activities, plus:</p> <ul style="list-style-type: none"> <li>Counseling (sexual and cancer risk)</li> <li>VIA</li> <li>Treatment with cryotherapy or referral</li> </ul>	<p>Pelvic exam</p> <p>Infection prevention</p> <p>Basic equipment, CO<sub>2</sub> and supplies</p>
<b>First Referral Level</b> <b>(District Hospital)</b>	<p>Above plus:</p> <ul style="list-style-type: none"> <li>Medical officers</li> <li>Nurse midwives</li> <li>(Ob/Gyn specialists)</li> </ul>	<p>Above activities (VIA, cryotherapy), plus:</p> <ul style="list-style-type: none"> <li>Visual Inspection of the cervix using acetic acid and low-power magnification (VIAM) or HPV testing</li> <li>LEEP or cone biopsy</li> <li>Simple hysterectomy</li> </ul>	<p>Limited specialty hospital</p> <p>Lab with HPV assessment capability</p> <p>LEEP machine and thin wire loops</p> <p>General anesthesia</p>
<b>Secondary and Tertiary Level</b> <b>(Regional or Referral Hospital)</b>	<p>Above plus:</p> <ul style="list-style-type: none"> <li>Ob/Gyn specialists</li> <li>(Ob/Gyn oncologists)</li> <li>(Radiotherapist)</li> </ul>	<p>Above activities, plus:</p> <ul style="list-style-type: none"> <li>Full diagnostics (colposcopy, biopsy, HPV)</li> <li>Radical surgery</li> <li>Radiotherapy</li> </ul>	<p>Full specialty hospital</p> <p>Radiation therapy services</p> <p>Chemotherapy</p>

<sup>a</sup> Knowledgeable people, local nongovernmental organizations and private groups

<sup>b</sup> Level where VIA and cryotherapy are appropriate

## REFERENCES

Alliance for Cervical Cancer Prevention (ACCP). 2004. *Planning and Implementing Cervical Cancer Prevention and Control Programs: A Manual for Managers*. ACCP.

Alliance for Cervical Cancer Prevention (ACCP). 2003. Effectiveness, safety, and acceptability of cryotherapy: A systematic literature review. *Cervical Cancer Prevention Issues in Depth*, No. 1. (January).

American College of Obstetricians and Gynecologists. 2004. ACOG Statement of Policy: Cervical cancer prevention in low-resource settings. *Obstetrics & Gynecology* 103: 607–609.

Belinson JL et al. 2001. Cervical cancer screening by simple visual inspection after acetic acid. *Obstetrics & Gynecology* 98(3): 441–444.

Blumenthal et al. 2005. Training for cervical cancer prevention programs in low-resource settings: Focus on visual inspection with acetic acid and cryotherapy [Review]. *International Journal of Gynecology and Obstetrics*. 89(Suppl 2): S30–S37.

Bosch FX et al. 1995. Prevalence of human papillomavirus in cervical cancer: A worldwide perspective. *Journal of the National Cancer Institute* 87(11): 796–802.

CDC. 1992. 1993 Revised classification system for HIV infection and expanded surveillance case definition for AIDS among adolescents and adults. *Morbidity and Mortality Weekly Report* (MMWR). December 18, 1992.

Denny L et al. 2002. Direct visual inspection for cervical cancer screening: an analysis of factors influencing test performance. *Cancer* 94(6): 1699–1707.

Denny L et al. 2000. Evaluation of alternative methods of cervical cancer screening for resource-poor settings. *Cancer* 89: 826–833.

Ellerbrock TV et al. 2000. Incidence of cervical squamous intraepithelial lesions on HIV-infected women. *Journal of the American Medical Association* 283(8): 1031–1037.

Ferlay J et al. 2001. *Globocan 2000: Cancer Incidence, Mortality and Prevalence Worldwide*. IARC Press: Lyon, France.

Gaffikin L et al. 2003. Performance of visual inspection with acetic acid for cervical cancer screening: A qualitative summary of evidence to date. *Obstetrical and Gynecological Survey* 58(8): 543–550.

Gaffikin L et al. (eds). 1997. *Alternatives for Cervical Cancer Screening and Treatment in Low-Resource Settings*. Workshop Proceedings (21–22 May). JHPIEGO: Baltimore, Maryland.

Goldie SJ et al. 2001. Policy analysis of cervical cancer screening strategies in low-resource settings: Clinical benefits and cost-effectiveness. *Journal of the American Medical Association* 285: 3107–3115.

Groopman J. 1999. Contagion. *The New Yorker* 75(26): 44–49.

Hildesheim A et al. 1999. Risk factors for rapid-onset cervical cancer. *American Journal of Obstetrics and Gynecology* 180 (3): 571–577.

International Agency for Research on Cancer (IARC) Working Group on Evaluation of Cervical Cancer Screening Programmes. 1986. Screening for squamous cervical cancer: Duration of low risk after negative results of cervical cytology and its implication for screening policies. *British Medical Journal* 293: 659–664.

International Conference for Population and Development (ICPD). 1994. *The Cairo Conference: A Programme of Action for Reproductive Rights?* Center for Reproductive Law & Policy: Cairo, Egypt.

Jones SB. 1999. Cancer in developing countries: A call to action. *British Medical Journal* 39: 505–508.

Kitchener HC and P Symonds. 1999. Detection of cervical intraepithelial neoplasia in developing countries. *Lancet* 353: 856–857.

Londhe M, SS George and L Seshadri. 1997. Detection of CIN by naked eye visualization after application of acetic acid. *Indian Journal of Cancer* 34(2): 88–91.

Lonky NM et al. 1997. Selecting treatments for cervical disease. *OBG Management* (January): 60–70.

Maggwa BN et al. 1993. The relationship between HIV infection and cervical intraepithelial neoplasia among women attending two family planning clinics in Nairobi, Kenya. *AIDS* 7(5): 733–738.

Magnusson P, P Sparen and U Gyllensten. 1999. Genetic link to cervical tumors. *Nature* 400: 29–30.

Mandelblatt JS et al. 2002. Costs and benefits of different strategies to screen for cervical cancer in less-developed countries. *Journal of the National Cancer Institute* 94(19): 1469–1483.

Massimi P and L Banks. 1997. Repression of p53 transcriptional activity by the HPV E7 proteins. *Virology* 227(1): 255–259.

McDonald C. 1999. Cancer statistics, 1999: Challenges in minority populations. *CA—A Cancer Journal for Clinicians* 49(1): 6–7.

Megevand E et al. 1996. Acetic acid visualization of the cervix: An alternative to cytologic screening. *Obstetrics & Gynecology* 88: 383–386.

Miotti PG et al. 1996. Cervical abnormalities, human papillomavirus, and human immunodeficiency virus infections in women in Malawi. *Journal of Infectious Diseases* 173(3): 714–717.

Mitchell MF et al. 1998. A randomized clinical trial of cryotherapy, loop electrosurgical excision and laser vaporization for treatment of squamous intraepithelial lesions of the cervix. *Obstetrics & Gynecology* 92: 737–744.

Moscicki A and N Jay. 2000. HPV infection in women with HIV disease: Prevalence, risk and management. *AIDS Reader* 10(11): 659–668.

National Institute of Allergy and Infectious Diseases (NIAID). 2001. *Workshop Summary: Scientific Evidence on Condom Effectiveness for Sexually Transmitted Disease (STD) Prevention*. Workshop Report (12–13 June 2000). NIAID: Bethesda, Maryland.

Nuovo GJ, R Banbury and PT Calayag. 1991. Human papillomavirus types and recurrent cervical warts in immunocompromised women. *Modern Pathology* 4: 632–635.

Palank C. 1998. An introduction to colposcopy concepts, controversies and guidelines. *ADVANCE for Nurse Practitioners* 6(10): 45–50, 91.

Parkin DM and R Sankaranarayanan. 1999. Prevention of cervical cancer in developing countries. *Thai Journal of Obstetrics and Gynaecology* 11(Suppl 1): 3–20.

Parkin M. 2000. Personal communication. Cited in: Preventing cervical cancer in low-resource settings. *Outlook* 18(1): 1–8.

Rodriguez-Reyes ER et al. 2002. Acetic acid test: A promising screening test for early detection of cervical cancer. *Analytical and Quantitative Cytology and Histology* 24(3): 134–136.

Sankaranarayanan R. 2001. *Visual Inspection with Acetic Acid (VIA): Introduction, Training Issues, Definition of Test Outcomes*. Discussion document (27–30 March). WHO: Geneva.

Sankaranarayanan R and R Wesley. 2000. Unpublished document.

Sankaranarayanan R, AM Budukh and R Rajkumar. 2001. Effective screening programmes for cervical cancer in low- and middle-income developing countries. *Bulletin of the World Health Organization* 79(10): 954–962.

Sankaranarayanan R et al. 2004. Accuracy of visual screening for cervical neoplasia: Results from an IARC multicentre study in India and Africa. *International Journal of Cancer* 110(6): 907–913.

Sankaranarayanan R et al. 1999. Visual inspection with acetic acid in the early detection of cervical cancer and precursors. *International Journal of Cancer* 80: 161–163.

Sankaranarayanan R et al. 1998. Visual inspection of the uterine cervix after the application of acetic acid in the detection of cervical carcinoma and its precursors. *Cancer* 83(10): 2150–2156.

Sherris J and C Herdman. 2000. Preventing cervical cancer in low-resource settings. *Outlook* 18(1): 1–8.

Singh et al. 2001. Early detection of cervical cancer through acetic acid application—an aided visual inspection. *Singapore Medical Journal* 42(8): 351–354.

Stentella P et al. 1998. HPV and intraepithelial neoplasia recurrent lesions of the lower tract: Assessment of the immune system. *European Journal of Gynaecological Oncology* 19(5): 466–469.

Stewart AC et al. 1996. Intratype variation in 12 human papillomavirus types: A worldwide perspective. *Journal of Virology* 70(5): 3127–3136.

UNAIDS. December 2006. *2006 AIDS Epidemic Update*. UNAIDS: Geneva.

University of Zimbabwe/JHPIEGO Cervical Cancer Project. 1999. Visual inspection with acetic acid for cervical cancer screening: Test qualities in a primary care setting. *Lancet* 353(9156): 869–873.

Walboomers JMM et al. 1999. Human papillomavirus is a necessary cause of invasive cervical cancer worldwide. *Journal of Pathology* 189(1): 12–19.

World Health Organization (WHO). 1986. Control of cancer of the cervix uteri. A WHO meeting. *Bulletin of the World Health Organization* 64(4): 607–618.

WHO. 2006. *Comprehensive Cervical Cancer Control: A Guide to Essential Practice*. WHO: Geneva.

Wright T. 1999. Personal communication.

Wright TC et al. 2006. HPV vaccines and screening in the prevention of cervical cancer; conclusions from a 2006 workshop of international experts. *Vaccine* 24S3: S3/251–S3/261.

Ylitalo N et al. 1999. Smoking and oral contraceptives as risk factors for cervical intraepithelial neoplasia. *International Journal of Cancer* 81(3): 357–365.



## TWO

# HUMAN PAPILLOMAVIRUS AND CERVICAL CANCER

## BACKGROUND

HPV is the most prevalent sexually transmitted infection in the world, occurring at some point in up to 75% of sexually active women (Groopman 1999). Although HPV infection is widespread, few people know that they are infected because they seldom have symptoms. In men, for example, when the virus infects the cells of the urethra, there is rarely a discharge or visible lesions on the penis. Even less well known is the fact that nearly all cervical cancers (99.7%) are directly linked to previous infection with one or more of the oncogenic (cancer-inducing) types of HPV (Judson 1992; Walboomers et al. 1999). Although women usually are infected shortly after they become sexually active—in their teens, 20s or 30s—progression to cervical cancer generally takes place over a period of 10 to 20 years. In rare cases, some types of early lesions become cancerous over a shorter time interval—within a year or two.

It is estimated that for every 1 million women infected, about 10% (100,000) will develop precancerous changes in their cervical tissue (dysplasia). Of these women, about 8% (8,000) will develop early cancer limited to the outer layers of the cervical cells (CIS), and roughly 1,600 will develop invasive cancer unless the precancerous lesion or CIS is detected and treated. In addition to the link between HPV and cervical disease, there is growing evidence that people with HPV who engage in anal intercourse may be at high risk for precancerous anal lesions as well as squamous cell cancer. According to a study of homosexual men, about 60% of those who are HIV-negative carry the HPV virus, whereas nearly 95% of HIV-positive men have HPV (Moscicki et al. 1999). Moreover, these men have been found to carry the same types of papillomaviruses (e.g., types 16 and 18) that cause cervical cancer. Finally, women with active infection can transfer the virus to their newborns (vertical transmission) during delivery, which may cause papillomavirus infection in newborns and possible subsequent laryngeal papillomatosis (Cason, Rice and Best 1998).

Currently, there is no treatment for HPV infection. Once infected, a person is most likely infected for life. In most cases, an active infection is controlled by the immune system and becomes dormant over time. It is not possible, however, to predict whether or when the virus will become active again. For example, one recent study followed more than 600 female university students who were tested for HPV every 6 months (Groopman 1999). Over the course of 3 years, new HPV infections occurred in more than 40% of the women. Most infections lasted about 8

months and then subsided. After 2 years, however, about 10% of the women still carried active virus in the vagina and cervix. In this study, the persistent infections were most commonly associated with the virulent, cancer-linked types of HPV. As discussed below, certain types of HPV, as well as immune-deficient conditions (e.g., HIV/AIDS), are associated with persistence of disease.

## THE VIRUS

Papillomaviruses were first recognized many years ago as the cause of warts on the hands and feet or condyloma accuminata on the pubic area (penis and urethra in men or vulva and vagina in women). For years, warts were considered mainly bothersome or ugly, rather than a forerunner of cancer. Indeed, the virus types that cause warts on fingers and toes usually are not dangerous. The types that target the face, however, can increase a person's risk of developing skin cancer. Still others, which grow mainly in the mouth and produce pea-sized lumps, can develop into fatal squamous cell cancers (Terai et al. 1999).

The papillomavirus is relatively small—just two strands of DNA contained in a round shell, or envelope, that looks like a golf ball when enlarged under an electron microscope (**Figure 2-1**).

**Figure 2-1. Electron Photomicrograph of Human Papillomavirus**



*Source:* Stannard/Photo Researchers 1998.

Because HPV cannot be cultured, and a reliable serologic test was not available until recently, it has been difficult to collect accurate information about the incidence and course of HPV infections. For example, prior to the 1990s, the only way cervical infection with HPV could be detected was by examining cells from Pap smears microscopically or by looking at the cervix through a colposcope. Using

DNA testing, which is now commercially available, scientists have identified nearly 100 types of papillomavirus—more than 40 of which preferentially infect the genital area (Wright et al. 2006). It remains unknown, however, why certain types of HPV target the skin on the hands or feet while others attack the lining cells of the mouth, and still others the genitalia of both men and women (Terai et al. 1999).

A link between HPV infection and cervical cancer was first demonstrated in the early 1980s. The 40 papillomavirus types that preferentially infect the genital area infect primarily the cervix, vulva and vagina in women; the penis in men; and the urethra and anus in both sexes. Of these types, only four are most often found within cervical cancer cells (so-called “high-risk” types), with type 16 accounting for about half of the cases in the United States and Europe. In Latin America, by contrast, types 39 and 59 are the most prevalent, whereas type 45 is common in West Africa (Groopman 1999; Stewart et al. 1996). And, as mentioned previously, HPV is present in virtually all cases of cervical cancer (Walboomers et al. 1999). There are several commercially available tests for the presence of HPV DNA in developed and in some developing countries. While they are reasonably sensitive and specific (see **Appendices A and B**) for detection of cervical precancer, the tests are relatively expensive and beyond what many developing countries can afford.

## **HOW HPV INDUCES CANCER**

Cervical cancer is probably one of the best-known examples of how infection with a virus can lead to cancer. In humans and animals, cell division is regulated largely by two proteins—one called Rb and the other p53. Recently it has been found that two genes in HPV, the so called E6 and E7 genes, produce proteins that can attach themselves to Rb and p53 and block their effect on regulating cell division (Massimi and Banks 1997). When this effect is blocked, the infected cells reproduce without any control. Although the virus serves only as the initiating event, over time some of the wildly growing cells develop permanent changes in their genetic structure that cannot be repaired, and are closely associated with the development of precancer. Once these genetic changes occur, some may eventually turn into cancer cells. Importantly, the affected cells also produce abnormal proteins, and these proteins can be found in both the cervical secretions and in the circulation, which has implications for development of future tests.

In the early stages, virus-infected cervical cells may show only small changes in size and shape when examined microscopically. With time, however, not only do the cells expand and become more distorted, but their neat arrangement in rows or columns on the surface of the cervix is destroyed. These changes are consistent with those of cervical dysplasia or CIN of varying degrees of severity, as seen by the pathologist when

examining a biopsy specimen of cervical tissue. In some women these premalignant cells, if left untreated, will slowly replace the normal cells on the surface of the cervix and CIS will develop. Finally, when the cells begin to grow through the normal surface layer into the muscle and deeper tissues, full-blown cancer is present.

## **RISK FACTORS FOR CERVICAL CANCER**

Epidemiologic studies have identified a number of factors that play a significant role in the development of CIN, a precursor to cervical cancer (Palank 1998). As shown in **Table 2-1**, both the type and the pattern of sexual activity, especially in teenagers, are major factors in determining whether a person becomes infected with HPV. As a result of relaxed attitudes about sexuality among adolescents in many cultures, the number of sexual partners that teenagers have before age 20 can be quite large, and each of their partners also may have had multiple partners. As a consequence, this pattern of sexual activity increases their risk of exposure to STIs, especially HPV.

**Table 2-1. Risk Factors for Cervical Cancer**

<b>RISK FACTORS</b>
Sexual activity (< 20 years)
Multiple sexual partners
Exposure to STI
Mother or sister with cervical cancer
Previous abnormal Pap smear
Smoking
Immunosuppression:
• HIV/AIDS
• Chronic corticosteroid use (asthma and lupus)

Another risk factor is having a blood relative (mother or sister) with cervical cancer. Magnusson, Sparen and Gyllensten (1999) compared the incidence of dysplasia and CIS in relatives of women with disease and in age-matched controls. They found a significant familial clustering among biological, but not adoptive, relatives. For biological mothers compared to control cases, the relative risk was 1.8, whereas for adoptive mothers the relative risk was not significantly different from controls (1.1). For biological full sisters, the relative risk was even higher (1.9), versus 1.1 for nonbiological sisters. These data provide strong epidemiological evidence for a genetic link to the development of cervical cancer and its precursors.

Suppression of the immune system due to HIV infection also is an important risk factor because it makes the cells lining the lower genital tract (vulva, vagina and cervix) more easily infected by the cancer-inducing types of HPV (Stentella et al. 1998). Other less common conditions that cause immunosuppression include those requiring chronic corticosteroid treatment, such as asthma or lupus (McDonald 1999). Women also increase their risk for CIN by engaging in other behaviors known to suppress the immune system. These include the use of recreational drugs, alcohol and cigarettes. The latter is particularly important because while a decrease in smoking among men has occurred, the number of women who smoke has increased dramatically in recent years—especially in teenage girls (McDonald 1999). Nicotine and the byproducts of smoking are thought to increase a woman’s relative risk for cervical cancer by concentrating in the cervical mucus and decreasing the immune capability of Langerhan’s cells to protect cervical tissue from invading oncogenic factors, such as HPV infection (Ylitalo et al. 1999).

As mentioned in **Chapter 1**, there is substantial evidence that HIV-positive women are at increased risk of developing cervical cancer as well (Judson 1992). In two studies, both from high HIV prevalence areas, a statistically significant association between HIV and CIN was reported (**Table 1-1**, page 1-5). Because the number of adolescents, as well as adults, with HIV is rising in most countries where cervical cancer is largely untreated, cervical cancer rates are expected to continue increasing, especially in areas where STI and HIV/AIDS rates are high.

Finally, in many developing countries, women who have abnormal Pap smears frequently do not receive treatment at an early stage when cervical cancer could be prevented because:

- there are long delays in reading and reporting the results;
- it is difficult to locate the patient once the report becomes available;
- the cost of treatment is not affordable for many women, even when simple outpatient procedures are used; and
- there is a lack of equipment as well as healthcare providers trained to use and maintain it.

As a consequence, even in countries where Pap smears are available, many women may not get the treatment they need it.

## **PREVENTING CERVICAL CANCER**

As mentioned above, HPV is the most prevalent sexually transmitted infection in the world. Although condoms and other safe-sex practices protect against many STIs, including HIV/AIDS, they are not nearly as effective in preventing HPV infection. This is because the papillomavirus

lives in the skin (squamous) cells covering the pubic area (vulva and shaft of the penis) as well as the interior cells lining the vagina and cervix in women, and urethra and anus in both sexes. Condoms do not cover the entire shaft of the penis, nor do they block contact with pubic skin. Therefore, during intercourse, even with a condom, skin cells containing HPV can come in contact with a woman's vulva or vagina, enabling the virus ultimately to reach the cervix. In addition, the friction of sexual intercourse is believed to cause tiny, microscopic tears in the vaginal wall making transmission far more likely. Moreover, even dead cells shed during intercourse can contain the virus and remain infective for days (Roden, Lowy and Schiller 1997).

## **PRIMARY PREVENTION**

The most effective way to prevent cervical and other genital cancers would be a vaccine. Individuals would need to be immunized at an early age before they are sexually active. The benefits of such a vaccine would be particularly significant in developing countries, where women's healthcare services are minimal. Designing a vaccine, however, will not be easy because an individual's immune response appears to be specific to the type of HPV. For example, a person protected against type 16 would still be at risk of infection with other cancer-inducing types, such as 18 or 33. Furthermore, there appear to be subtypes or variants within type 16, and perhaps with other types as well. Finally, as mentioned above, the types of HPV associated with cervical disease vary by geographical area. With the increase in international travel, the various carcinogenic types soon will be spread throughout the world. Therefore, a vaccine that contained a mixture of several types would have to be created (Groopman 1999, Stewart et al. 1996).

Despite these problems, at least two vaccines are available that can protect women from cancer-linked papillomaviruses (HPV types 16 and 18): bivalent (Cervarix®) and quadrivalent (Gardasil®) vaccines. Both are considered prophylactic vaccines and preferably given prior to natural exposure to HPV types 16 and 18 (Wright et al. 2006). It will most likely be several years, however, before either vaccine will be affordable in developing countries. Blumenthal (2002) discusses the complexities of implementing a vaccination program and the need to continue secondary prevention programs in the interim, and stresses the difference between a vaccine and a vaccination program. Indeed, a vaccine itself is not effective unless a successful program exists to ensure availability, access and acceptability. Finally, there also are attempts to produce a therapeutic vaccine that would boost the immune system of someone who is already infected and cause the cancer to regress or even disappear. These vaccines

are targeted to inactivate the E6 and E7 proteins, the viral proteins that block the action of the cell growth regulating proteins (Rb and p53) (Massimi and Banks 1997).

Clinical trials have been conducted to study the effectiveness of both therapeutic and prophylactic HPV vaccines. In their review article, Schreckenberger and Kaufman (2004) conclude that while successful prophylactic HPV vaccines have entered large clinical trials, therapeutic HPV vaccines have been less successful. As a result, adjuvants (components that enhance the immune response) for systemic and local immune modulation will be mandatory for effective therapy. Similarly, a review article by Roden, Ling and Wu (2004) demonstrates the progress of preventative vaccine development. Preventative vaccines target proteins connected with the capsule of the virus and induce neutralizing antibody production. While therapeutic vaccines pose many challenges, multiple forms of vaccines are being tested that target HPV-16 E6 and E7, and each have their own advantages and disadvantages. In a landmark double blind placebo controlled study by Koutsky et al. (2002), an HPV-16 virus-like particle was used as the vaccine and yielded 100% efficacy for 768 women. However, the authors only assessed one subtype of HPV and it is likely that multiple vaccinations would be needed to induce immunity. Finally, currently tested vaccines require refrigeration, which can sometimes be a barrier to access in developing countries.

Until a protective vaccine is widely available and accessible, primary prevention must focus on continuing to change sexual practices and other behaviors that increase a person's risk of becoming infected, and secondary prevention programs must continue to screen and manage women with precancer or with cancer. Just as with the fight against HIV/AIDS, risk reduction counseling related to the risk factors listed above (**Table 2-1**) must be incorporated into all levels of the healthcare system, especially those dealing with young people. The messages must alert teenagers that practices designed to minimize the risk of exposure to HIV/AIDS and other STIs (e.g., the use of male or female condoms) may not be as effective for HPV prevention.<sup>1</sup> In addition, vigorous efforts to discourage adolescents, especially young girls, from starting smoking and initiating sexual activity must be widely and continually disseminated.

---

<sup>1</sup> A recent case-control study, however, has shown that male condom use, which significantly decreases the amount of infectious virus deposited in the vagina during sexual intercourse, offers substantial protection (Wen et al 1999).

## SECONDARY PREVENTION

As discussed in **Chapter 1**, although at present prevention of HPV infection is difficult, for women already infected the immediate need is to:

- identify those with early, easily treatable precancerous lesions; and
- cost-effectively treat them before the lesions progress to cancer.

Thus, the remaining chapters of this manual are devoted to providing health professionals working at all levels of the healthcare system with the necessary new knowledge they need to understand how to manage this problem in low-resource settings where Pap smears are not available. When this knowledge is combined with competency-based training in VIA and cryotherapy, healthcare providers should be able to effectively counsel women at risk of cervical cancer and to test, treat or refer women with cervical disease.

## REFERENCES

Blumenthal P. 2002. Immunization against cervical cancer: Who? When? Where? *Medscape General Medicine* 4(4). Available at <http://www.medscape.com/viewarticle/444979>.

Cason J, P Rice and JM Best. 1998. Transmission of cervical cancer-associated human papilloma viruses from mother to child. *Intervirolgy* 41(4–5): 213–218.

Groopman J. 1999. Contagion. *The New Yorker* 75(26): 44–49.

Judson FN. 1992. Interactions between human papillomavirus and human immunodeficiency virus infections. *IARC Scientific Publications* 119: 199–207.

Koutsky LA et al. 2002. A controlled trial of a human Papillomavirus type 16 vaccine. *New England Journal of Medicine* 347: 1645–1651.

Magnusson P, P Sparen and U Gyllensten. 1999. Genetic link to cervical tumors. *Nature* 400: 29–30.

Massimi P and L Banks. 1997. Repression of p53 transcriptional activity by the HPV E7 proteins. *Virology* 227(1): 255–259.

McDonald C. 1999. Cancer statistics, 1999: Challenges in minority populations. *CA—A Cancer Journal for Clinicians* 49(1): 6–7.

Moscicki AB et al. 1999. Risk factors for abnormal anal cytology in young heterosexual women. *Cancer Epidemiology, Biomarkers & Prevention* 8(2): 173–178.

Palank C. 1998. An introduction to colposcopy concepts, controversies and guidelines. *ADVANCE for Nurse Practitioners* 6(10): 45–50, 91.

Roden RB, M Ling and TC Wu. 2004. Vaccination to prevent and treat cervical cancer. *Human Pathology* 35(8): 971–982.

Roden RB, DR Lowy and JT Schiller. 1997. Papillomavirus is resistant to desiccation. *Journal of Infectious Diseases* 176(4): 1076–1079.

Schreckenberger C and AM Kaufman. 2004. Vaccination strategies for the treatment and prevention of cervical cancer. *Current Opinion in Oncology* 16: 485–491.

Stentella P et al. 1998. HPV and intraepithelial neoplasia recurrent lesions of the lower tract: assessment of the immune system. *European Journal of Gynaecological Oncology* 19(5): 466–469.

Stewart AC et al. 1996. Intratype variation in 12 human papillomavirus types: A worldwide perspective. *Journal of Virology* 70(5): 3127–3136.

Terai M et al. 1999. High prevalence of human papillomavirus in the normal oral cavity of adults. *Oral Microbiology and Immunology* 14(4): 201–205.

Walboomers JMM et al. 1999. Human papillomavirus is a necessary cause of invasive cervical cancer worldwide. *Journal of Pathology* 189(1): 12–19.

Wen LM et al. 1999. Risk factors for the acquisition of genital warts: Are condoms protective? *Sexually Transmitted Infections* 75: 312–316.

Wright TC et al. 2006. HPV vaccines and screening in the prevention of cervical cancer; conclusions from a 2006 workshop of international experts. *Vaccine* 24S3: S3/251–S3/261.

Ylitalo N et al. 1999. Smoking and oral contraceptives as risk factors for cervical intraepithelial neoplasia. *International Journal of Cancer* 81(3): 357–365.



## THREE

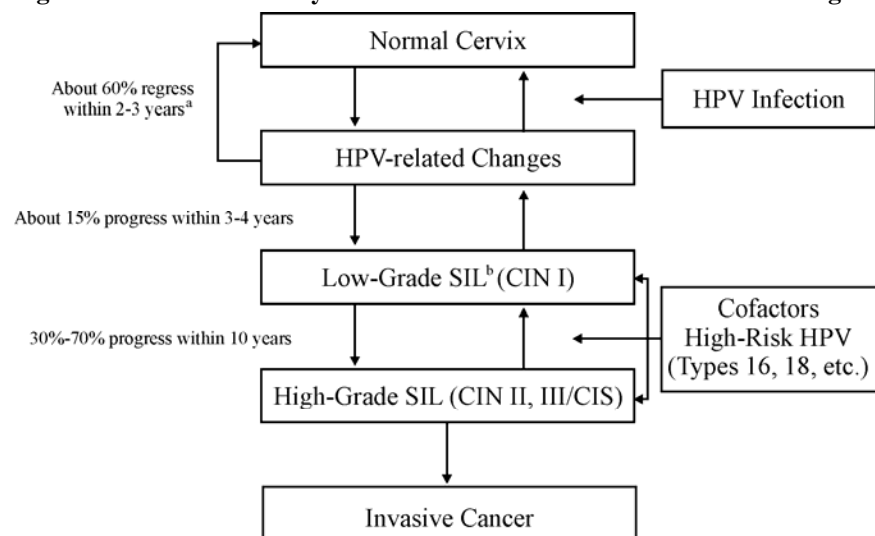
# PATHOPHYSIOLOGY OF CERVICAL CANCER

## BACKGROUND

A clear understanding of the natural history of cervical cancer is key to planning and implementing a rational, cost-effective cervical cancer prevention program. Accepted models of the natural history of cervical cancer have changed in recent years. Because the natural history of the disease has a direct impact on testing, treatment and followup strategies, programs should base their decisions on the most current models.

When programs to prevent or control cervical cancer were first developed, it was assumed that cervical cancer developed from precancerous lesions (broadly known as dysplasia<sup>1</sup>), progressing steadily from mild to moderate to severe dysplasia and then to early cancer (CIS) before invasive cancer develops. In fact, it now appears that the direct precursor to cervical cancer is high-grade dysplasia (CIN II or III), which can progress to cervical cancer over a period of up to 10 years or more (**Figure 3-1**). Most low-grade dysplasia (CIN I) disappears without treatment or does not progress, particularly those changes seen in younger women. Prevalent cases, however, where disease has been present for a longer period of time, are less likely to regress. This is the situation that exists when cervical cancer testing is first being started in a country or region.

**Figure 3-1. Natural History of Cervical Cancer—Current Understanding**



<sup>a</sup> Prevalent cases will have a lower regression rate.

<sup>b</sup> For definitions of SIL, CIN and CIS, see Glossary. For an illustration of the cellular changes with each, see page 3-8.

Source: PATH 1997.

<sup>1</sup> For definition of dysplasia, see the **Glossary**.

## KEY CONSIDERATIONS FOR LOW-RESOURCE SETTINGS

The natural history of cervical cancer suggests that screening should initially focus on women at greatest risk for high-grade dysplasia—women in their 30s and 40s. Although cervical cancer most often develops in women after age 40, high-grade dysplasia (CIN II or III) generally is detectable up to 10 years or more before cancer develops, with a peak dysplasia rate at about age 35. Although unscreened women over 50 remain at relatively high risk of cervical cancer, women in this group who have had one or more negative tests in their 30s or 40s, are at much lower risk (see **Figure 1-2**, page 1-2).

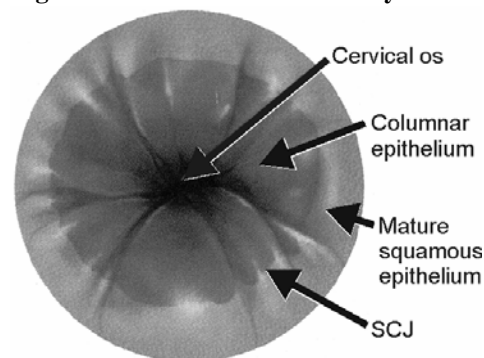
Data from some countries suggest that age-specific rates for CIN, CIS and cervical cancer have shifted downward by about 5 years due, in part, to increasing STD and HIV/AIDS rates. If true, screening recommendations in these countries may need to be adjusted accordingly. The observation of more cases in younger women, however, may just be a reflection of changes in the age structure of the population or of cervical cancer screening patterns, rather than a shift in age-specific rates.

## ANATOMY AND PHYSIOLOGY OF THE NORMAL CERVIX

### **Age-Related Changes in the Transformation Zone**

During the first 18 to 20 weeks of embryonic life, the original tall (columnar) cells that line the vagina and cervix are gradually replaced by flat (squamous) cells. As shown in **Figure 3-2**, throughout early childhood and until puberty, the squamous cells meet the remaining columnar cells at the squamocolumnar junction (SCJ), a thin line well out on the face of the cervix.

**Figure 3-2. The Cervix at Puberty**

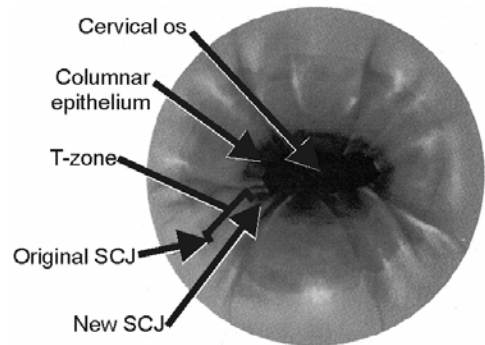


*Adapted from: Rubin 1999.<sup>2</sup>*

<sup>2</sup> Reprinted with permission from ADVANCE Newsmagazines.

With the onset of puberty, which is marked by increasing levels of the female hormones (estrogen and progesterone), and continuing throughout most of the reproductive years, the columnar cells inside the SCJ are gradually replaced by newly developing squamous cells. This process, called squamous metaplasia, occurs in the transformation zone (T-zone), the portion of the cervix between the original SCJ (before puberty) and the new SCJ

**Figure 3-3. The Cervix During the Reproductive Years**

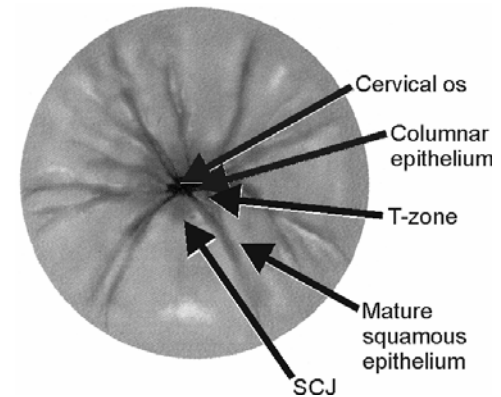


*Adapted from: Rubin 1999.<sup>2</sup>*

(**Figure 3-3**). The T-zone may be either a wide or a narrow area on the surface of the cervix, depending on several factors, such as age, parity, prior infections and exposure to female hormones. Abnormal changes of the cervix, such as dysplasia (CIN) and cancer, almost always develop in this portion of the cervix. Thus, screening measures such as VIA, cervicography and colposcopy are directed at examining the T-zone and, especially, the SCJ.

Finally, by the time menopause is reached, mature squamous cells now cover nearly the whole face of the cervix, including the entire T-zone, and the SCJ, if visible, is located at or inside the cervical os (**Figure 3-4**).

**Figure 3-4. The Cervix at Menopause**



*Adapted from: Rubin 1999.<sup>2</sup>*

**Importance of These Changes in Preventing Cervical Cancer**

In the early years following puberty, most of cells within the T-zone are columnar cells. Replacement of these cells with newly developing squamous cells is just beginning. It is during this time period that the cells within the T-zone, and especially those at the SCJ, are most vulnerable to the cancer-related changes induced by certain types of HPV and other cofactors (Geng et al. 1999).

Most adolescent girls do not understand that the younger they are when they become sexually active, the more chance there is that, if exposed to

<sup>2</sup> Reprinted with permission from ADVANCE Newsmagazines.

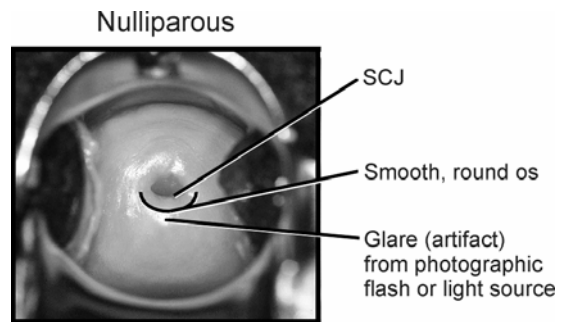
one or more of the cancer-inducing types of HPV, they will develop precancerous changes that ultimately could result in cancer as they get older. Using condoms (either male or female) helps protect these delicate cells, but delaying sexual intercourse until nearly age 20 is even more protective.

## APPEARANCE OF THE CERVIX IN NORMAL AND ABNORMAL STATES

The detailed description of each cervix shown in this section is intended to supplement that provided in the full-color *Atlas of Visual Inspection of the Cervix with Acetic Acid (VIA)*. Therefore, when reading this section, please refer to the atlas to better understand the changes in each cervix being described.

### **Nulliparous**

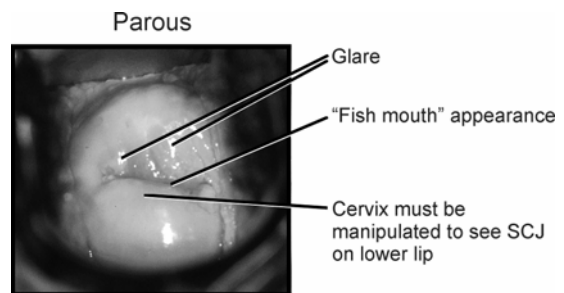
Note the smooth round opening (os) of the cervix. The normal trauma associated with the passage of a fetus through the cervix during birth (or late abortion) usually results in a less symmetrical “worn” cervix. The SCJ is visible as a faint, thin white line just at the entrance to the cervical canal. Note the difference in color of the glandular (columnar) epithelium, which is red due to the blood vessels beneath the single layer of cells. The squamous epithelium is less red (pink) because it is several layers thick.



There is a small amount of glare visible, mainly on the squamous epithelium, which is an artifact caused by the photographic flash or light source. Clinically, glare can be differentiated from potential pathology by either moving the light source or changing position while viewing the cervix. Although the artifact due to glare will move with the change in light source or viewing angle, color changes indicative of diseased tissue will not.

### **Parous**

Compare this photo with the nulliparous cervix. The cervical os is uneven, with a worn appearance. Such a cervix is often described as having a “fish mouth” appearance. For examiners, the many contours and surfaces of such a cervix may require that they manipulate the cervix with a swab in order to get as thorough a view of the SCJ as

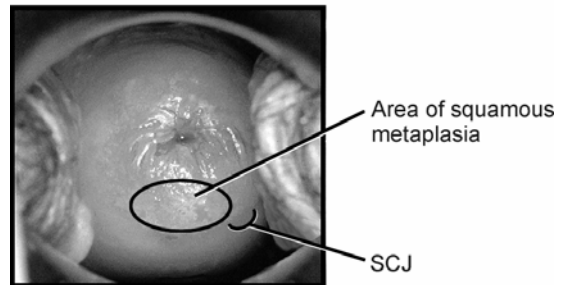


possible. In the cervix seen here, in order to get a complete view of the SCJ, the lower lip of the cervix needs to be manipulated downward. This is perhaps best accomplished by using a swab either on the cervix itself or by placing a swab in the cull de sac and pushing upward, thus bringing the cervix downward and into view. In large and patulous (spread apart) cervixes, it may be necessary to open the bivalve speculum wider to better expose the SCJ. There is also an area of squamous metaplasia (see below) occurring in a patulous portion of the cervix. This patulous area is probably the result of obstetrical trauma with subsequent scarring and healing.

**Squamous Metaplasia**

Squamous metaplasia is a physiologic process through which the glandular cells lining the cervical canal near the SCJ are gradually replaced with squamous cells. This process is a result of the cervix's exposure to noxious agents in the environment, such as bacteria, viruses and unclean foreign bodies. In the cervix shown here, there is a visible area of squamous metaplasia on the lower lip of the cervix, close to the SCJ. It has a faint white, translucent appearance, almost as if a thin white veil were laid onto the cervix. Unlike mucus, it will not wipe away.

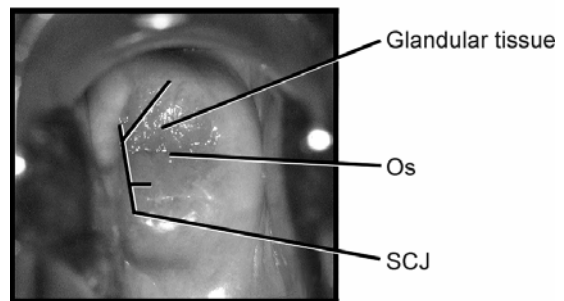
Squamous metaplasia



**Ectopy/Ectropion**

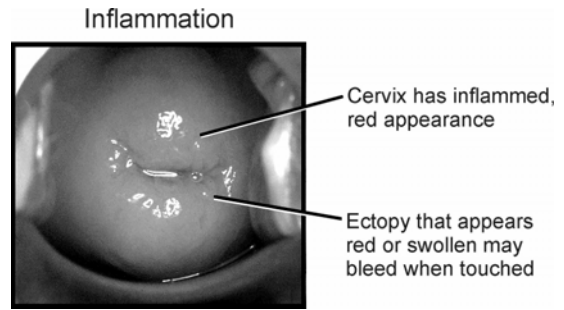
Exposure to hormones such as estrogen and progesterone may affect the appearance of the cervix. This effect is typified by the increased presence of glandular tissue on the outer surface of the cervix. This finding, often called ectropion or ectopy, is not a pathological condition, but rather a variant of cervical appearance. The cause of ectopy is unclear, but may relate to exposure to internal hormonal sources (such as may occur during periods of anovulation, normal menstruation or pregnancy). It may also result from exposure to synthetic hormones, when patients use hormonal methods of contraception such as combined estrogen/progestin pills and progestin-only methods. In this photo, there are neither areas of obvious acetowhite change (see below), nor is this cervix particularly likely to bleed easily when touched (friable), both of which indicate a normal cervix.

Ectropion/Ectopy



**Inflammation**

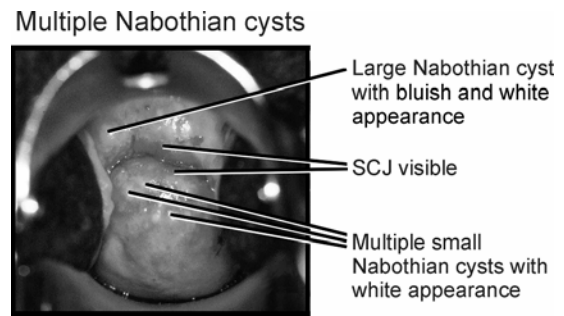
An inflamed cervix will appear red and swollen and look as if it has a “beefy” consistency. The areas of ectropion noted in this cervix also look somewhat reddened and swollen. Sometimes inflamed areas may bleed on contact.



Certain infections can cause the cervix to have a distinctive appearance. Most notably, infection with the *Trichomonas* organism produces what is sometimes called a “strawberry” cervix, with alternating areas of red epithelium and pale dots on the surface of the cervix (reminiscent of a strawberry) and a generally inflamed appearance. Because of the inflammatory process, the SCJ may be somewhat blurry or indistinct but, after staining with acetic acid, should be identifiable. In the cervix pictured here, the SCJ is visible upon close inspection, but will require manipulation of the cervix to see around the inflamed glandular tissue.

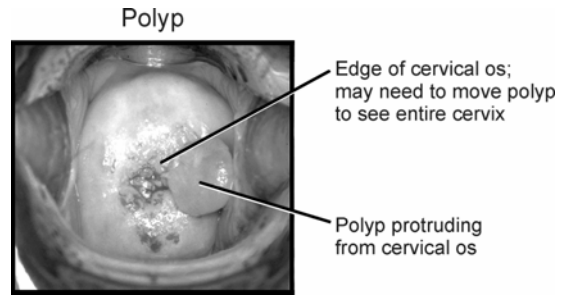
**Nabothian Cysts**

Nabothian cysts are formed when glandular tissue is folded over and covered by squamous epithelium, which often occurs as part of the metaplastic process. They are not pathological. In such cases glandular,

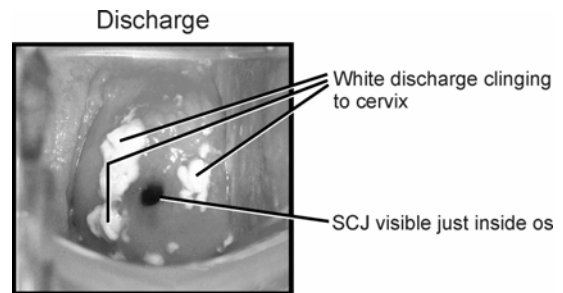


mucus-secreting cells are trapped beneath the surface of the squamous epithelium. As the glandular cells continue to secrete mucus, small cysts develop under the surface and often protrude outward. These cysts may appear bluish or, as seen here, have a distinctly white appearance. They usually occur at some distance away from the SCJ and are only rarely seen in the glandular tissue. Unlike mucus, they cannot be wiped away, but it is usually possible to differentiate these defects from pathological lesions due to their marked, pimple-like appearance. In fact, that is exactly what Nabothian cysts are—cervical pimples. In this photo, there are numerous small cysts on the posterior lip, and a larger one at 10 o’clock. The larger cyst has both blue and white components, and has a visibly tense, protruding appearance. The normal SCJ is well seen on the anterior lip, and after cervical manipulation, may also be seen on the lower lip.

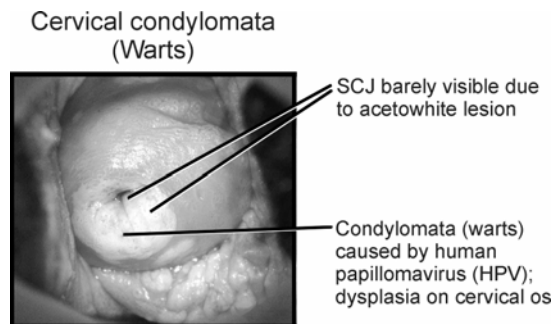
**Polyp** Polyps are found fairly often and represent small segments of glandular tissue that have grown away from the lining of the cervix or endometrium and become a finger-like projection into the cervical canal and/or vagina. Patients with polyps may often present with prolonged or heavy menstrual bleeding or, quite commonly, post-coital bleeding. As in this picture, polyps are often very mobile and can be pushed in different directions in order to reveal the SCJ. The presence of a polyp sometimes obscures a view of the SCJ, making screening by visual inspection impossible. Because polyps are composed entirely of glandular tissue, they do not become acetowhite when stained with acetic acid and should not be confused with cervical cancer or its precursors. Prolapsed fibroid tumors (leiomyoma) can sometimes look like polyps.



**Discharge** In some situations, a discharge may be present at the cervix. The color of such discharges is a purulent-appearing mix of green, yellow and gray, or as shown here, cheesy and white. Any discharge should be wiped off the cervix before VIA because discharge can obscure the SCJ or be confused with a lesion. The cervix itself is normal and the SCJ can be seen.



**Warts** Cervical condylomata (warts) are caused by HPV. This virus is at the root of the pathological process that results in cervical problems such as dysplasia and cancer. Warts are often quite noticeable when they occur on the external genitalia, but when they infect the cervix can also cause clearly visible lesions such as the one shown here. Once stained with acetic acid, the warty tissue will become bright white with a marked thickening of the cervical or vaginal mucosa. If on close inspection, it is often possible to note a distinctly lumpy, irregular contour to the surface of the affected area. In this cervix, the entire SCJ appears to be occupied by the warty tissue that also appears to be extending into the cervical canal.

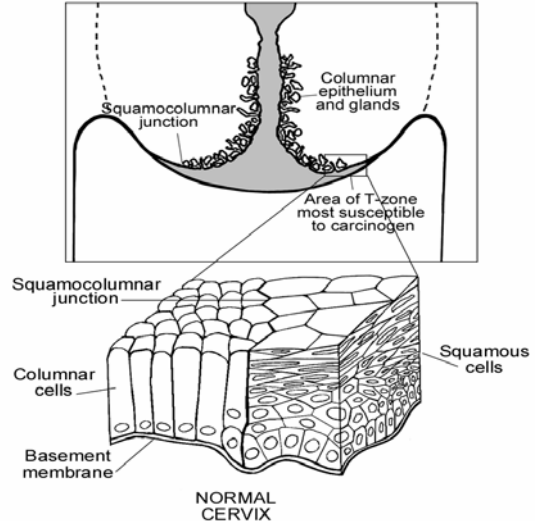


Warts by themselves are usually low-grade lesions. Extensive warts, as seen in this case, however, may mask higher grade lesions in the deeper tissue. Studies indicate that such lesions often regress spontaneously and that treatment is not always successful in the long run. If treatment is desired, a variety of techniques can be provided, including cryotherapy or LEEP. It is important to note that warts are transmitted by sexual contact. In order to avoid transmission to a partner, patients should be advised to use condoms during sexual intercourse.

**Squamous Intraepithelial Lesions**

The face (exocervix) of the normal cervix is largely covered with squamous epithelium (Figure 3-5). The endocervix, which consists of glandular columnar epithelium, lines the cervical canal and is visible at the cervical os.

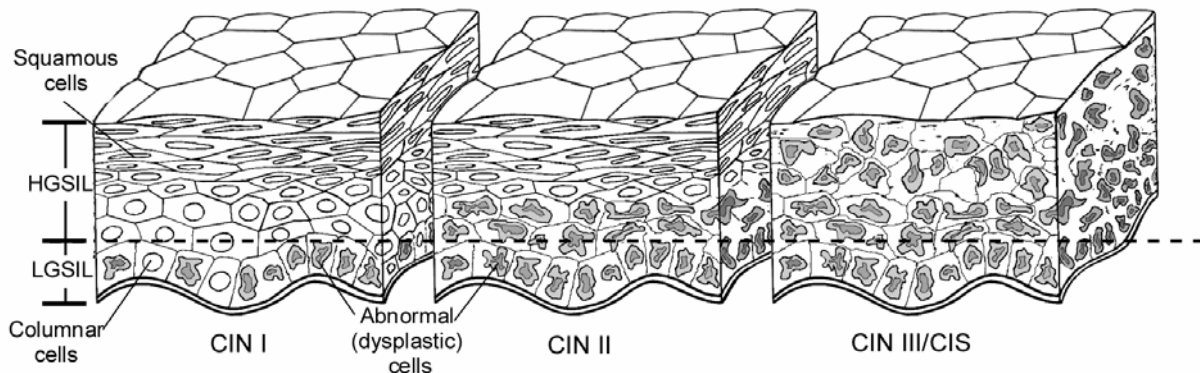
Figure 3-5. Normal Cervix



Low-grade squamous intraepithelial lesions (LGSIL), or CIN I, are ones in which up to a third of the epithelium is occupied by dysplastic cells (Figure 3-6). Such lesions are also often visible during VIA.

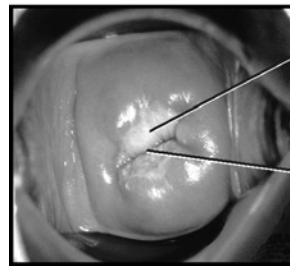
High-grade squamous intraepithelial lesions (HGSIL), or CIN II and CIN III/CIS, are ones in which more than one third of the depth of the cervical epithelium is occupied by dysplastic cells, as shown in Figure 3-6. Therefore, when acetic acid is applied to the cervix, it is more thoroughly absorbed than in low-grade lesions, thereby resulting in more clearly visible acetowhite lesions.

Figure 3-6. Microanatomy of Dysplasia



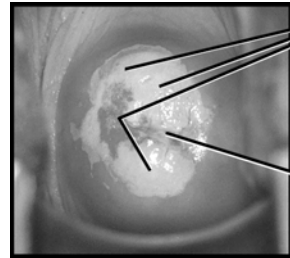
In the cervixes shown here, there are noticeable areas of “white” epithelium at various locations on the cervix. One can also see that in some cases, some manipulation may be required to ensure that the entire exocervix is visible. In high-grade lesions, such areas are usually larger, thicker and demonstrate a more clearly dull white area of abnormality than lower grade lesions. Such lesions must be treated. If the entire lesion is clearly seen, and its limits do not exceed the area that could be covered with a cryotherapy probe (< 75% of the cervix), cryotherapy is an excellent treatment choice. With good technique, cure rates of 90% can be achieved.

High-grade squamous intraepithelial lesions



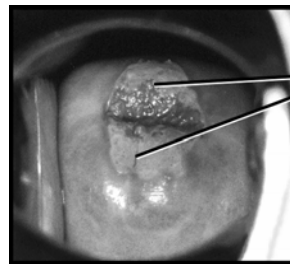
Dull, thick, acetowhite lesion

SCJ visible with manipulation of cervix

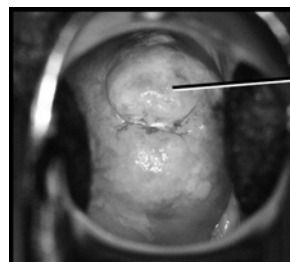


Extensive, thick, white dull, raised, acetowhite lesion on SCJ

Portion of SCJ visible. Lesion extends from SCJ outward onto surface of cervix.

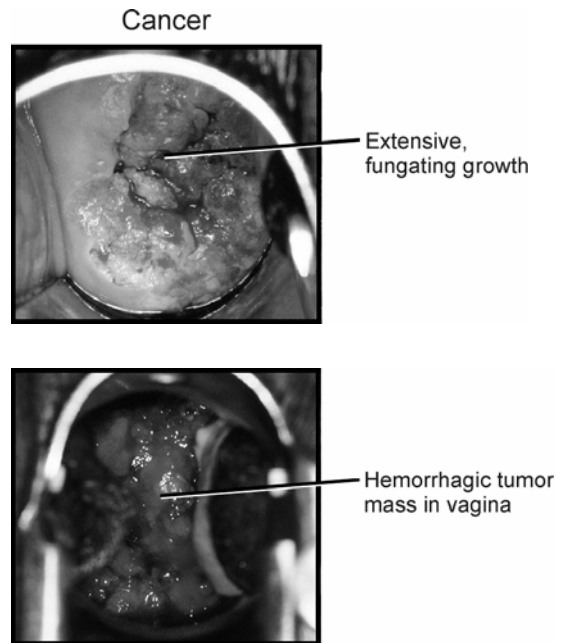


Thickened, raised acetowhite lesions at 12:00 and 6:00. At 12:00, same ulceration is also visible.



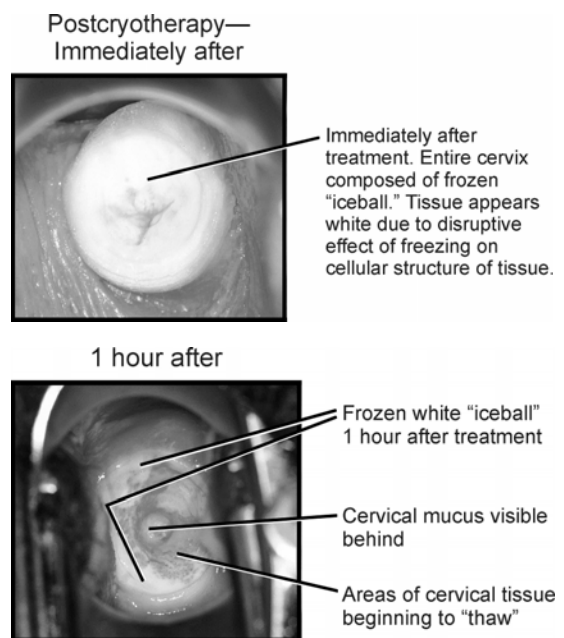
Diffuse, dense, raised, dull, acetowhite lesion, irregular margins

**Cancer** Visibly invasive cancer can have a variety of appearances. Most commonly, if the cancer is early, the cervix will appear densely white, with a thick, knobby mass extruding from some portion of the cervix. Such masses may have a “cauliflower”-like appearance and will bleed easily with contact. Sometimes contact will cause fragments of the mass to break off, which can also cause bleeding. A bimanual exam will confirm the presence



of an enlarged, hard cervix which, depending on the stage of progression, may or may not be mobile. In the photographs shown here, the visibly apparent qualities described above are both present. In the top photo, a fungating, white growth is seen. Abnormal vessels in the form of deep grooves on the cervix are also visible. In the bottom photo, a hemorrhagic, cauliflower-like mass is seen protruding into the vagina. The mass is so large that the cervix itself cannot even be seen. If possible, patients with cervixes such as these should be referred to a center where treatment such as radical surgery, radiation therapy or, in some cases, palliative measures can be undertaken.

**Postcryotherapy** Cryotherapy creates an “iceball” on the cervix. Immediately after cryotherapy, almost the entire cervix will appear frozen and white. It will gradually thaw, producing a watery discharge that may last for several weeks. As soon as 1 hour after treatment, the tissue will begin to thaw. Some of the color will return to the tissue, but the tissue will be fragile and will require a few weeks to heal.



**REFERENCES**

Anderson M et al. (eds). 1997. *A Text and Atlas of Integrated Colposcopy*. Mosby: St. Louis, Missouri. 10–11.

Geng I et al. 1999. Atypical immature metaplasia (AIM) of the cervix: Is it related to high-grade squamous intraepithelial neoplasia (HSIL)? *Human Pathology* 30(3): 345–351.

JHPIEGO. 1999. *Atlas of Visual Inspection of the Cervix with Acetic Acid (VIA)*. JHPIEGO: Baltimore, Maryland.

Rubin MM. 1999. Cytologic concerns in adolescents: entering the transformation zone. *ADVANCE for Nurse Practitioners* 7: 53–54, 56.



## FOUR

# TALKING WITH WOMEN ABOUT CERVICAL CANCER

## BACKGROUND

Women who are being tested for cervical cancer with VIA need accurate information about the disease and the testing and treatment procedures. Healthcare providers should encourage all women, especially those between the ages of 25 and 45, to be tested for cervical cancer. Women also need counseling to help them make an informed decision about what to do, should treatment or referral be needed. Important points to cover in this counseling are:

- what and where the cervix is;
- what is cervical cancer and how it is detected;
- what causes cervical cancer and the risk factors for developing it;
- what can be done to prevent cervical cancer, with emphasis on precancerous lesions or disease; and
- a brief description of the test used to examine the cervix and treat it, if indicated.

Healthcare providers should be able to talk about the diagnosis of and possible treatment for cervical cancer using words the woman can understand. Unfortunately, it is often difficult for providers to talk with women about cervical cancer. It is equally difficult for women to talk openly about a disease that is sexually transmitted and that, if left undiagnosed and untreated, can lead to death. Talking about this sensitive problem will be easier if providers:

- have accurate, complete and up-to-date technical information about cervical cancer tests, such as Pap smears or VIA, and which tests are available;
- have accurate information about the types of treatment available for precancerous and cancerous lesions; and
- are able to build honest and understanding relationships with the women they counsel.

In addition, healthcare providers should recognize that most precancerous lesions of the cervix do not have clinical symptoms. Thus, most women being tested will consider themselves completely healthy. Thus, it is important to promote testing as a means of **preventing** cervical cancer.

Finally, providers should know and be able to use basic counseling techniques. These techniques will help the provider establish a relationship with the client. If a woman believes in the competence and honesty of the provider, she will be more likely to have the test and, if necessary, accept treatment and return for a followup visit. In addition, she will be more likely to refer others who need cancer testing.

## CLIENT RIGHTS<sup>1</sup>

Every woman being tested for precancerous lesions or treated for abnormal findings has a **right to information** about her condition. Information should be given to her (and her family, where appropriate) in a supportive, confidential and nonjudgmental manner, and it should deal with:

- the results of the test;
- the time frame for treatment, if any;
- procedure to be used, as well as the risks and benefits;
- her consent to the treatment; and
- the need for referral to another facility, if necessary.

Every woman has the **right to discuss** her concerns and condition in an environment in which she feels confident. The patient should be assured that her conversation with the counselor or healthcare provider will be private and confidential.

Women should know in advance the type of physical examination (e.g., pelvic examination) or procedure (e.g., cryotherapy) that is going to be performed.

When a woman is undergoing a physical examination or procedure, it should be carried out in an environment (e.g., examination or procedure room) in which her **right to privacy** is respected. For example, when receiving counseling or undergoing a physical examination or procedure, she should be informed about the role of each person in the room (e.g., healthcare providers, students, supervisors, instructors, researchers, and so on).

Women should be made as comfortable as possible when receiving services. To a certain extent, this is related to the adequacy of service delivery facilities (e.g., proper ventilation, lighting, seating and toilet facilities). Moreover, the time she spends waiting to receive care should be reasonable.

---

<sup>1</sup> *Adapted from:* Huezo and Carignan 1997.

Finally, women have a **right to express** their views about the service they receive. A woman's opinions about the quality of services, either gratitude or complaint, together with her suggestions for changes in service provision, should be viewed positively in a program's ongoing effort to monitor, evaluate and improve its services. Regularly interviewing women about the services they have received and incorporating their suggestions for change will also improve the quality of care.

## **CONFIDENTIALITY**

All information that a woman provides should be treated confidentially. This includes information about her medical history and the conditions causing her to seek care, the services provided to her and any family planning decisions she makes. Confidentiality requires that the healthcare provider not discuss this information with the woman's partner, family, person accompanying her to the healthcare facility or staff members not directly involved in her treatment without her consent (except where required in a **life-threatening** medical emergency). On the other hand, if the woman **wants** to involve a spouse or partner in decision-making, her wishes should be followed.

## **PRIVACY**

Creating an atmosphere of privacy is critical to protecting the woman's confidentiality, sense of security and dignity, and willingness to communicate honestly. Often, simple changes in the physical setting where clients are treated or counseled will offer the woman more privacy. The following are some suggestions for maintaining privacy:

- Use a separate area, such as an office, closed treatment room or curtained space, to encourage open communication when giving pre-procedure information, discharge information or counseling.
- Draw curtains around the treatment area whenever the woman is undressed or, if curtains are not available, turn the treatment table so that the woman's feet are not facing a doorway or public space. Also provide a curtained area for changing clothes.
- Use drapes (or sheets, or even clothing if drapes are not available) to cover the woman's legs and body during examinations and procedures.
- During treatment, limit the number of people in the client care area to those involved in providing care. Even if the woman gives permission for a clinical training demonstration, limit the number of persons who are in the room during the demonstration. In addition, staff and trainees in the client care area should refrain from casual conversation among themselves.

## **WHO SHOULD TALK WITH A WOMAN**

Providers who might talk to women about cervical cancer include physicians, nurses and other persons who work in a health center, Maternal and Child Health/Family Planning clinic, STI clinic or any other healthcare facility providing services to women. All providers can learn counseling techniques that will help them be more understanding and sensitive toward clients. Providers who take reproductive health histories, perform gynecological examinations, make diagnoses and prescribe treatment should learn how to ask and answer questions about cervical cancer in a well-informed, honest and culturally sensitive way.

## **BEING A GOOD COUNSELOR**

A good counselor:

- Encourages maximum participation and involvement by the woman (or couple) and helps her make her own decision
- Is an information giver, facilitator and problem solver; suggests alternatives; helps the woman analyze and choose from known options; does not prescribe solutions; and helps her understand that she is making her own choice or decision
- Helps the woman to reveal her personality and life situation rather than make assumptions
- Determines her concerns and other issues that could be barriers to effective learning

### **General Advice When Counseling**

A woman may become embarrassed when discussing testing for cervical cancer because it involves having a pelvic examination. Therefore, try to set the tone of the visit in a low-key, nonpressured manner, and assure her that the conversation is confidential. Finally, be sensitive to any cultural and religious considerations and respect her views. Additional tips for talking with a woman (or couple) include the following:

- Listen to what the woman has to say and encourage her to express her concerns; try not to interrupt her.
- Let the woman know that she is being listened to and understood.
- Use supportive nonverbal communication, such as nodding and smiling.
- Answer her questions directly in a calm, reassuring manner.
- Keep the message simple by using short sentences.

- Avoid sophisticated medical terms; instead, use words that the woman will understand.
- Give the woman written information (if available and appropriate) to remind her of instructions.
- Finally, ask her to repeat back to you the key points to ensure her understanding.

## **COUNSELING PRIOR TO VIA TESTING**

Once a woman has agreed to be examined, explain in detail the VIA procedure and describe what steps will be taken should an abnormality be detected (see **Figure 6-1**, page 6-3). Tell her that treatment of many types of precancerous lesions that may be identified can be performed immediately, if she desires.

A woman who is interested in being tested by VIA should be given information about the following:

- The nature of cervical cancer as a disease and consequence of a HPV infection
- Availability of HPV vaccines and who can benefit most from them
- Risk factors for the disease
- The role and importance of VIA testing
- Consequences of not being tested
- Treatment options if the VIA test is abnormal.

While performing the VIA test, continually reassure the woman and inform her of the findings, including whether immediate treatment with cryotherapy may be needed. If the woman tests negative for VIA, counsel her about the meaning of the test results and when to return for future screening. The length of time until her next screening test should be consistent with local or national guidelines.

## **COUNSELING PRIOR TO CRYOTHERAPY**

All women have a **right to decide freely** whether or not to receive treatment. In some countries, written consent may be required for all treatment procedures. The health worker obtaining the woman's verbal consent for cryotherapy should follow these steps:

- Explain in detail, in a nonthreatening manner and in language the woman can understand, the cryotherapy procedure, its risks, benefits, likelihood of success and alternatives (**Table 4-1**).

**Table 4-1. Expected Side Effects of Cryotherapy**

Side Effect	Management
Cramping	<ul style="list-style-type: none"> <li>• Counsel patient before the procedure to expect some degree of cramping <b>during</b> and <b>after</b> the procedure and that cramping usually stops shortly after procedure.</li> <li>• Reduce cramping by pressing lightly on the cervix with the cryotherapy probe.</li> <li>• If cramping is severe, provide oral analgesic (acetaminophen or ibuprofen).</li> </ul>
Vaginal discharge (profuse, watery)	<ul style="list-style-type: none"> <li>• Counsel patient to expect a discharge lasting 2–4 weeks. Provide patient with undergarment and feminine pads.<sup>a</sup></li> <li>• Counsel patient to expect discharge to change color from a pink tint to clear white or a yellow tint (occasionally streaked with blood).</li> <li>• Counsel patient to return if discharge changes to foul-smelling or is pus-colored (if so, evaluate for infection and treat with antibiotics).</li> <li>• Strongly advise abstinence from sexual intercourse for 4 weeks.</li> <li>• If abstinence is unlikely, advise condom use for 4 weeks to prevent pelvic infection.</li> </ul>
Spotting/light bleeding	<ul style="list-style-type: none"> <li>• Counsel patient to expect spotting/light bleeding for 1–2 weeks.</li> <li>• Counsel patient to return for evaluation if there is heavy bleeding.</li> </ul>

<sup>a</sup>If undergarments or feminine pads are not available, cloth or other soft material may be used.

- Allow time for and encourage the woman to ask questions and discuss her condition.
- Ask the woman if she gives consent for treatment.

A woman with evidence of precancerous cervical changes (VIA test-positive) should be given the above information plus additional information about STIs and how to prevent them.

## COUNSELING FOLLOWING CRYOTHERAPY

Before leaving the health facility, a woman should receive counseling regarding:

- the details of self-care at home,
- conditions that might require coming to the clinic as soon as possible for care outside of the scheduled visits (**Figure 4-1**),

- the need to abstain from sexual intercourse for 4 weeks following treatment and a 2-month supply of condoms in case total abstinence for this long is not possible,<sup>2</sup> and
- when she should return for her next scheduled visit.

**Figure 4-1. Warning Signs**

If you have any of the following, you should return to this or the nearest health facility:

- Fever for more than 2 days
- Severe lower abdominal pain, especially if you have a fever
- Bleeding for more than 2 days that is heavier than your heaviest days of menstrual bleeding
- Bleeding with clots

## **QUESTIONS FREQUENTLY ASKED BY WOMEN**

**Q:** Why should I have this screening test?

**A:** Cervical cancer is a serious health problem for women living in developing countries. It is a major cause of cancer death among women between the ages of 35 and 60. Women with cervical cancer often have symptoms such as bleeding or lower abdominal pain. When these symptoms are present, the cancer is usually advanced and little treatment is available. But cervical cancer can be easily prevented through a simple test such as VIA to detect abnormal cells on the cervix. By examining the cervix before there are any symptoms, any abnormality can be found and effective treatment provided so that the cancer will be prevented.

**Q:** What is cervical cancer, and how would I get it?

**A:** Cervical cancer is a consequence of an STI. This means that the cervix has been exposed to one or more cancer-inducing types of HPV that, over time, have produced abnormal changes in the cells of the cervix. HPV is transmitted by sexual contact. Sometimes the presence of the virus takes the form of warts, either on the outside of the genital area or internally, such as on the cervix. When abnormal cells are present on the cervix and are not treated, they can become cancerous and eventually spread the disease beyond the cervix and pelvic organs. If it is not diagnosed and treated early, the cancer will lead to death.

---

<sup>2</sup> Because women who are seropositive for HIV may have increased shedding of the HIV virus following treatment and during the healing process, abstinence for up to 4 weeks is strongly recommended in all women.

**Q:** I am a smoker. Does that increase my risk of cervical cancer?

**A:** Smoking is a risk factor for cervical cancer. Although the exact mechanism is not clear, women who smoke appear to have a higher risk of cervical cancer, as well as other cancers, than nonsmokers. The reason may be related to the effect of nicotine and other byproducts of smoking, which concentrate in cervical mucus and decrease the ability of the cervix to resist infections by one or more types of HPV. Certainly, one way to reduce this risk is to stop smoking!

**Q:** How does VIA work?

**A:** Washing the cervix with vinegar allows the healthcare provider to see the difference between a cervix that looks healthy and one that looks abnormal. The vinegar turns abnormal cells white.

**Q:** If I have a positive test, does that mean that I have cancer?

**A1:** No. However, if abnormal cells that could become cancer are seen and not treated, then cervical cancer could result. To prevent this from happening, treatment that will be almost 90% effective in curing this problem for the next 5 or more years can be provided.

**A2:** Sometimes the test is positive (meaning that the healthcare provider thinks the cervix is abnormal) but, if other tests were performed, they might not show these abnormal areas. Thus, there is the possibility that treatment could be offered when, in fact, there might not actually be disease present. If you have certain risk factors for cervical cancer, such as being a smoker, having a history of STIs, having had multiple sexual partners, or having had a previous abnormal test (Pap smear), then there is a greater chance that you could have disease. In these cases, it is more likely that if the provider thinks the test is positive, it really is positive.

**A3:** If there is evidence or a suspicion of cancer, and not just precancerous changes, you should be referred to a hospital in order to determine the stage of the cancer and be offered treatment that is not available at the local facility. This may include surgical procedures or other procedures to assess the amount of disease present or to remove diseased tissue as much as possible.

**Q:** What is the treatment if there are abnormal (precancerous) cells?

**A:** The treatment involves freezing the abnormal cervical tissue. The procedure is known as cryotherapy, and it is a simple outpatient procedure. To do cryotherapy, an instrument, which can become very cold, is put on the cervix and the cells of the cervix are frozen. Once the cells have been frozen, they will die and fall off the cervix. You will notice this in the form of a heavy, watery discharge that lasts up to 4–6 weeks after treatment.

**Q:** How effective is this treatment?

**A:** Cryotherapy is about 90% effective in curing this problem for at least 5 years.

**Q:** Will this treatment hurt?

**A:** During the treatment, you may feel some mild cramping and a cold sensation in the vagina and lower abdomen. The cramping will disappear quickly over the next 15 to 30 minutes and is easily treated with an oral pain medication. For the next few days you may have some occasional mild cramping for which you may take whatever you might ordinarily take for menstrual cramps.

**Q:** What are the side effects of the treatment?

**A:** The most common side effect of the cryotherapy is a heavy watery discharge for 4–6 weeks. Almost everyone who gets this treatment has this discharge. Some women also may have light bleeding or cramping. During this time, you should not put **anything** in your vagina. This means you cannot have sex, douche or use tampons. If it is absolutely impossible to avoid sex over the 4 weeks following treatment, it is very important that you or your partner uses a condom.

**Q:** What could happen if I don't use a condom?

**A:** The freezing treatment creates a “wound” on the cervix, which needs time to heal. While this wound is healing, you will be more susceptible to getting or transmitting a sexually transmitted infection such as chlamydia, gonorrhea or HIV/AIDS. That's why it is so important to use a condom.

*Talking with Women About Cervical Cancer*

**Q:** What is the advantage of the treatment if I might not actually have disease?

**A:** The advantage of the treatment is that you will most likely not have cervical cancer in the next 10 years. Even when no abnormal tissue is seen, the earliest form of disease might be present. Providing this treatment will cause new healthy cells to grow on the cervix, thus reducing the chance that a cancer could occur.

**REFERENCES**

Huezo CM and C Carignan.1997. *Medical and Service Delivery Guidelines*, Second edition. International Planned Parenthood Federation, Medical Department: London.

Program for Appropriate Technology in Health (PATH). 1997. *Planning Appropriate Cervical Cancer Control Programs*. PATH: Seattle, Washington.

## FIVE

# PREVENTING INFECTIONS IN HEALTHCARE WORKERS<sup>1</sup>

## BACKGROUND

Infectious diseases, such as puerperal sepsis, tuberculosis and cholera, continue to be some of the leading causes of death worldwide. Healthcare workers as well as the clients and patients they serve are at risk of getting these diseases. The spread of infections within healthcare facilities results in large part from the failure of healthcare workers to wash their hands **before** and **after** contact with each client or patient—a lesson learned more than 100 years ago (“Handwashing: A modest measure...” 1999). The current epidemic spread of bloodborne viral diseases, including hepatitis B, C, and D and HIV/AIDS, heightens the importance of healthcare worker safety. As a consequence, infection prevention strategies should focus on both:

- preventing the spread of infection to clients and patients, and
- protecting healthcare workers at all levels by providing a safer work environment.

Most infections can be spread before symptoms are present. Therefore, exposure to any blood or other body fluids from a client or patient, through needlesticks or other injuries or splashes into eyes and mouth (mucous membranes), brings a risk of infection. Many healthcare workers are only vaguely aware of the risk they face while at work; some still believe that little can be done to protect them.

Although infection prevention (IP) addresses exposure from both animate and inanimate objects and deals extensively with hospital-acquired infections, this chapter focuses on practices that reduce healthcare workers’ exposure to infection from clients, patients and other staff in the clinic and ambulatory surgical center. More detailed information on preventing exposure from inanimate objects and how to decontaminate, clean and either sterilize or high-level disinfect instruments, gloves and other items can be found in *Infection Prevention: Guidelines for Healthcare Facilities with Limited Resources* (Tietjen et al. 2003) and **Appendix C**.

---

<sup>1</sup> Adapted with permission from: Tietjen LG. 1997. Preventing infections in healthcare workers. *Outlook* 15(4): 1–3.

## THE DISEASE TRANSMISSION CYCLE

Teaching healthcare workers how to protect themselves and their patients is more important than ever. If they know how to protect themselves and use IP measures consistently, they will help protect their patients as well. The first step in this process is to understand how diseases are spread. Knowing the disease transmission cycle is important if healthcare workers are to:

- prevent the spread of infection during medical and surgical procedures,
- teach others the factors required for transmission to occur, and most importantly,
- teach others **how to** interrupt the process.

Microorganisms live everywhere in our environment. Humans normally carry them on their skin and in the upper respiratory, intestinal and genital tracts. These microorganisms are called **normal flora**. In addition, microorganisms live in animals, plants, soil, air and water. Some microorganisms are more **pathogenic** than others, that is, they are more likely to cause disease. Given the right circumstances, however, **all** microorganisms may cause infection.

For bacteria, viruses and other infectious agents to survive and spread successfully, certain factors or conditions must exist. The essential factors in the transmission of disease-producing microorganisms (pathogens) from person to person are illustrated and defined in **Figure 5-1**.

Interrupting this cycle is the goal of IP practices. Most practices aimed at protecting the healthcare worker (e.g., wearing gloves or eyewear) block access to places of entry. Handwashing and procedures for processing inanimate objects block the method of transmission by removing the microorganisms. Finally, vaccines reduce the susceptibility of the host, and prevent the disease even if the host is exposed.

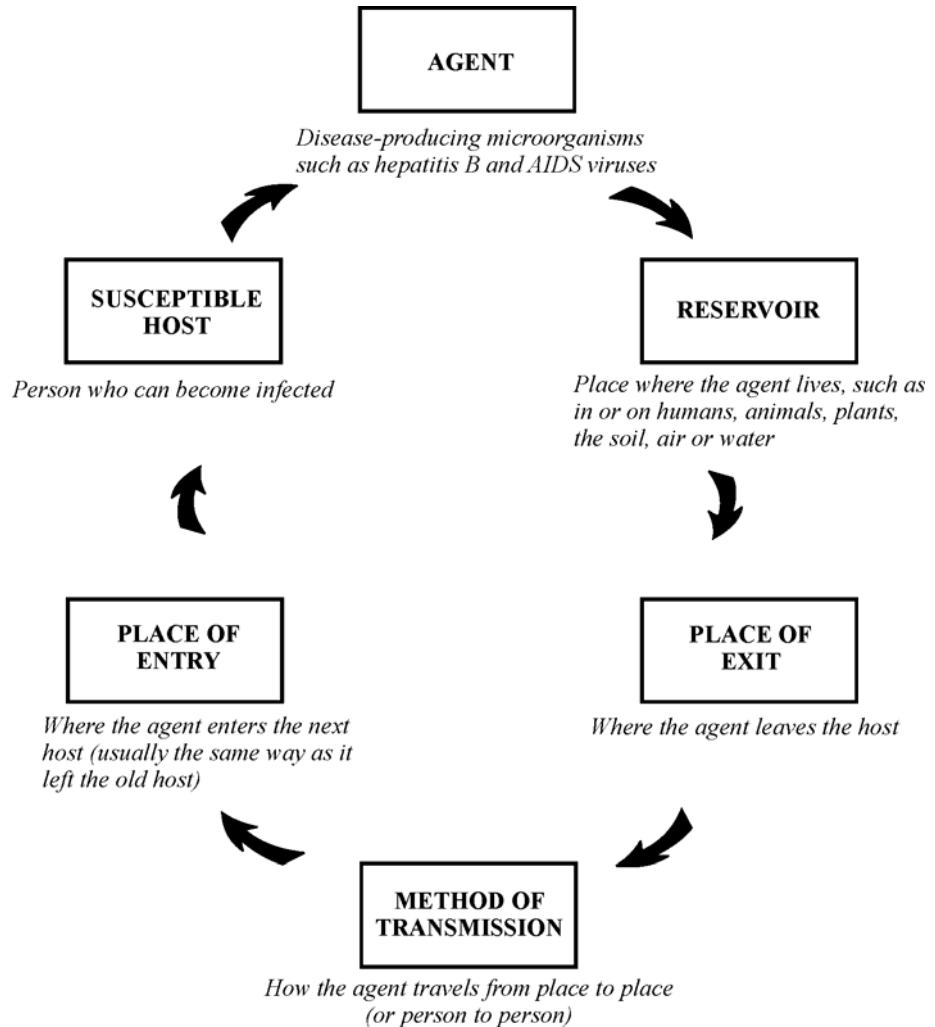
## HOW RISKY HEALTHCARE WORK IS

In a recent US survey, only truck drivers and laborers were reported to have higher on-the-job accident rates than healthcare workers (US Department of Labor 1995). Although exposure to biologic agents and subsequent infection are not the only occupational hazards faced by healthcare workers, infections, especially those caused by bloodborne organisms, present the greatest risk. Contact with blood and body fluids is the most common occupational risk faced by healthcare workers. For example, in the US alone, more than 800,000 needlestick injuries occur

each year despite continuing education and vigorous efforts aimed at preventing them (Rogers 1997).

Although there is a growing awareness of the seriousness of AIDS and hepatitis B, C, and D, as well as how these viruses are transmitted, many healthcare workers do not perceive themselves to be at risk. Even those who know that precautions such as handwashing and using gloves are important do not use them regularly. In part, this is due to the mistaken belief that these diseases are largely confined to certain “at-risk” groups—sex workers, IV drug users or homosexuals—and to urban areas. Although this may have been true several years ago, in 1998 WHO/UNAIDS estimated that worldwide there were more than 33.4 million people living with the AIDS virus and that this virus is increasingly affecting the heterosexual population as well as spreading to rural areas (WHO 1998).

**Figure 5-1. The Disease Transmission Cycle**



Other factors also contribute to the lack of compliance, including the perception that healthcare facilities are risky places to work and little can be done to make them safer. There is also a mistaken belief that there is a conflict of interest between providing the best care and protecting oneself from getting an infection (Gershon 1996). In many settings a lack of sufficient staff and an inappropriate staff mix to meet patient needs magnify these problems (Institute of Medicine 1996).

## **MAKING INFECTION PREVENTION PROGRAMS WORK**

Implementing effective strategies to ensure that healthcare workers follow IP guidelines is crucial to preventing the spread of infection. Education and other efforts intended to make the healthcare facility safer should be directed to all healthcare workers—not just physicians and nurses. In some countries housekeeping staff have a rate of needlestick injuries second only to operating room staff. This is due in large part to used needles being incorrectly discarded and housekeeping staff not being taught how to protect themselves (Tietjen et al 1992).

Compliance with IP guidelines can be strengthened if there is consistent support for safety efforts from program managers. This support includes ensuring that dangerous practices are eliminated, identified deficiencies are corrected, and staff are actively encouraged to suggest better safety practices. It is also important that supervisors regularly provide feedback and reward appropriate IP practices, and that role models, especially physicians and other senior staff, support recommended IP practices and model appropriate behavior (Lipscomb and Rosenstock 1997). Finally, educational programs geared to problem solving—not just providing information—and addressing psychosocial factors (minimizing stress, emotional strain and interpersonal problems) can lead to better compliance and improved safety of healthcare workers (Rogers 1997).

## **HOW HEALTHCARE CAN BE MADE SAFER**

Most infectious agents are transmitted by contact with blood and body fluids and most infections can be spread before symptoms are present. Therefore, it is essential that healthcare workers treat **all** clients and patients as if they are infected (Blumenthal and McIntosh 1996). The following precautions should be used routinely by **all** healthcare workers:

- **Wash hands** before and after each client or patient contact—the single most practical procedure for preventing the spread of infection.
- **Wear gloves** when touching anything wet—broken skin, mucous membranes, blood or other body fluids (secretions or excretions), soiled instruments, gloves and medical waste.

- Use **physical barriers** (protective goggles, face masks and plastic aprons) if splashes and spills of **any** body fluids (secretions or excretions) are anticipated, for example, during vaginal deliveries.
- Use **safe work practices** such as safely passing sharp instruments; properly disposing of medical waste; and not recapping, breaking, or bending needles or disassembling needles and syringes prior to disposal.

Because of the importance of each of these precautions, additional information on each one is summarized in the following sections.

### **Wash Hands**

Routine **handwashing** for 10 to 15 seconds before and after contact with family planning clients or patients may be the single more important procedure in preventing infections. The vigorous rubbing together of all surfaces of lathered hands mechanically removes most microorganisms. Using soap and water when available or an easy-to-make antiseptic (alcohol/glycerin), waterless handrub is effective. Healthcare workers in the US have been found to wash their hands only 40% of the time, even in intensive care units where patients are most vulnerable and resistant organisms most common (Griffin 1996). To encourage handwashing, program managers should make every effort to provide soap, a continual supply of clean water, either from a tap or bucket, and single-use towels. And, where handwashing is not convenient, making an antiseptic handwash available can significantly improve compliance (Voss and Widmer 1999; Zaragoza et al. 1999).

#### **ALCOHOL HANDSCRUB SOLUTION**

An inexpensive, nonirritating alcohol solution for handscrub can be made by adding either glycerine\* or Sorbitol® to alcohol (2 ml in 100 ml 60–90% ethyl or isopropyl alcohol) (Pierce 1990). Use 3 to 5 ml for each application and continue rubbing the solution over the hands until they are dry (usually about 2–5 minutes), using a total of 6 to 10 ml per scrub.

\* Glycerine is often sold in cosmetic departments as a hand softener.

### **Wear Gloves**

**Gloves** should be worn by all healthcare workers prior to contact with blood and other body fluids from any client or patient. This also includes the staff who clean up after a procedure and wash instruments. The type of gloves to use depends on the task. For example, thin, fitted latex gloves are required for surgery; inexpensive, disposable exam gloves for performing pelvic examinations and doing VIA testing; and thick utility gloves for washing instruments, cleaning up spills and disposing of medical waste. Gloves should be changed after each client or patient contact to prevent cross-contamination. For example, after performing a VIA test or cryotherapy, staff should remove their gloves and wash their hands before writing up notes or doing anything else.

If **surgical gloves** are being reused, operating room staff should “double glove” for procedures where blood or body fluid contamination is routine (for example, vaginal deliveries or Cesarean sections) because invisible tears in the gloves can occur with use and reprocessing.

**Use Physical Barriers**

Physical barriers protect the skin and mucous membranes of the healthcare worker from splashes or contact with blood and other body fluids. While gloves should be worn for all procedures, other protective barriers may not be needed for simple procedures in which minimal contact is expected. If splashes or spills are expected, goggles or face masks should be used to protect the eyes, nose and mouth. Protective clothing helps to protect the healthcare workers’ clothing and may prevent fluids from soaking through to the skin. Plastic aprons are most effective because they do not allow any fluids to pass through. Plastics and treated fabrics are more effective barriers than paper or cloth, but they are not widely available in many countries.

**Use Safe Work Practices**

Safe work practices help protect staff from exposures to family planning clients or patients and inanimate objects such as instruments and waste. Because injuries from sharps are the most dangerous (i.e., most likely to transmit HIV/AIDS), particular attention should be paid to how sharps are handled.

For example, specific approaches to **prevent needlestick injuries** include:

- Placing puncture-proof disposal containers for needles and other sharps instruments near patient beds or examining tables.
- Training all staff to immediately dispose of needles and syringes in sharps containers **without** recapping. (Attempting to recap accounts for one third of all needlesticks.)
- Training staff in the one-hand recapping technique if recapping must be done.

Barrier precautions will provide sufficient protection when working with almost all clients or patients. Isolate patients only if secretions (airborne) or excretions (urine or feces) cannot be contained. This would include, for example, patients who have active tuberculosis.

**INFECTION PREVENTION TIPS**

IP precautions should be part of every procedure. In family planning and women's health clinics, for example, gynecologic procedures, even pelvic exams, can expose healthcare workers to body fluids. Listed below are the specific IP practices that should be followed when doing VIA testing or cryotherapy:

- Wash hands thoroughly with soap and water before each examination.
- When possible, have the client wash her genital area before the pelvic examination.
- Use high-level disinfected (or sterile) instruments and surgical gloves (both hands). Alternatively, new examination gloves can be used.
- Properly dispose of waste material (gauze, cotton and disposable gloves).
- Decontaminate instruments and reusable items immediately after using them.
- Wash hands thoroughly with soap and water after removing gloves.

Finally, while not specifically a barrier precaution, when possible healthcare workers should take advantage of available immunizations, especially hepatitis B vaccine. Being vaccinated protects not only healthcare workers but also their fellow workers, clients and families.

**WHAT TO DO IF EXPOSURE OCCURS**

When any exposure to blood or other body fluids occurs, the following steps may reduce the risk of infection with HBV, HIV and other bloodborne pathogens.

- For exposure to skin or mucous membranes, wash the affected area immediately with soap and water, and rinse thoroughly to remove any potentially infectious particles.
- When a puncture wound or cut occurs, allow it to bleed. Cleanse and rinse the wound with soap and water. (Irrigating with saline, alcohol or iodine has not been shown to decrease risk of infection with HBV or HIV, and may even result in irritation and scarring.)
- For exposure to the eyes, flush the eye immediately with water, then irrigate for 30 minutes with normal saline.

Healthcare workers who are exposed to blood or body fluids should be given complete information about treatment options so that they can make an informed choice. If available, an antiretroviral agent, such as zidovudine (ZDV or AZT), should be offered within 1–2 hours after exposures with the highest risk of transmission. Healthcare workers should be aware of what antiretroviral agents are locally available and where to obtain them. The US Centers for Disease Control consider exposure to be high risk if:

- the injury to the healthcare worker is deep,
- there is visible blood on the device causing injury, or
- the injury was caused by a device previously placed in the client's vein or artery.

Treatment should continue for 4 weeks. All staff with possible exposures should be tested for at least 6 weeks following exposure, if possible. For less risky exposures, prophylaxis is not recommended.

## **MAINTENANCE OF A SAFE ENVIRONMENT**

Maintaining a safe, infection-free environment is an ongoing process that requires close supervision and frequent reminders to healthcare staff. With diligent application of the recommended practices described in this chapter, most infections and transmission of diseases, such as hepatitis B and HIV/AIDS, can be avoided. These practices, however, must be conscientiously applied before, during and after each procedure. Laxity at any point in the routine can have disastrous results for the safety of healthcare workers and their clients and patients.

## **REFERENCES**

Blumenthal P and N McIntosh. 1996. *PocketGuide for Family Planning Service Providers: 1996–1998*, Second edition. JHPIEGO: Baltimore, Maryland.

CDC. 1996. *Update: Provisional public health service recommendations for chemoprophylaxis after occupational exposure to HIV*. US Department of Health Services: Wilmington, North Carolina.

Gershon R. 1996. Facilitator report: Bloodborne pathogens exposure among healthcare workers. *American Journal of Industrial Medicine* 29: 418–420.

Griffin K. 1997. They should have washed their hands. *Health* November/December: 82–90.

Handwashing: A modest measure—with big effects. 1999. *British Medical Journal* 318: 616.

Institute of Medicine. 1996. *Nursing Staff in Hospitals and Nursing Homes—Is It Adequate?* National Academy Press: Washington, DC.

Lipscomb J and L Rosenstock. 1997. Healthcare workers: Protecting those who protect our health. *Infection Control and Hospital Epidemiology* 18: 397–399.

- Pierce M. 1990. Personal communication. Arlington, Texas.
- Rogers B. 1997. Health hazards in nursing and healthcare: An overview. *American Journal of Infection Control* 25: 248–261.
- Tietjen L. 1997. Preventing infections in healthcare workers. *Outlook* 15: 1–3.
- Tietjen L, D Bossemeyer and N McIntosh. 2003. *Infection Prevention: Guidelines for Healthcare Facilities with Limited Resources*. JHPIEGO: Baltimore.
- United Nations Joint Programme on HIV/AIDS and the World Health Organization. 1998. *AIDS Epidemic Update—December 1998*. World Health Organization: Geneva.
- US Department of Labor, Bureau of Labor Statistics. 1995. *Current Population Survey, 1995 Annual Averages*. US Department of Labor: Washington, DC.
- Voss A and AF Widmer. 1997. No time for handwashing? Handwashing versus alcoholic rub: Can we afford 100% compliance? *Infection Control and Hospital Epidemiology* 18: 205–208.
- Zaragoza M et al. 1999. Handwashing with soap or alcoholic solutions. A randomized clinical trial of its effectiveness. *American Journal of Infection Control* 27: 258–261.



## SIX

# CLIENT ASSESSMENT AND VIA TESTING

## BACKGROUND

VIA is one way of performing cervical cancer testing. As discussed in **Chapter 1**, its advantages include the simplicity of the technique and the ability to provide women with an immediate result. As with any other medical procedure, training with guided practice is required in order to perform VIA competently, but such training can be given easily to almost any level of healthcare provider.

## WHO SHOULD BE TESTED

Testing for cervical cancer or its precursors is recommended for **any woman between the ages of 30 and 45**. Cervical cancer rates peak among women between the ages of 40 and 50, so testing should take place during the ages in which detecting a precancerous lesion is most likely, normally 10 to 20 years earlier.

A number of risk factors are associated with the development of cervical cancer and, presumably, its precursors. Risk factors include the following:

- Young age at onset of sexual activity (age < 20)
- Multiple sexual partners (woman or partner)
- History or presence of an STI, such as chlamydia or gonorrhea, and especially HIV/AIDS
- Mother or sister with cervical cancer
- Previous abnormal Pap smear
- Smoking

In addition, as discussed in **Chapter 2**, women who have an immunosuppressive disorder (e.g., HIV/AIDS) or who use corticosteroids chronically (e.g., for treatment of asthma or lupus) are at increased risk of developing cervical cancer if they have HPV (Rubin 1999).

Women with any of these risk factors may be the most important group to receive testing and treatment services in low-resource settings. In fact, focusing testing and treatment services on women who are between 30 and 45 or have risk factors such as a high risk for STI is likely to improve the positive predictive value of VIA. In addition, because rates of disease are likely to be higher in these groups, the chances of detecting

precancerous lesions is greater, thus increasing the cost-effectiveness of the testing program and reducing the chance of unnecessary treatment.

## **WHEN TO PERFORM VIA**

VIA can be performed at any time in the menstrual cycle, including during menses, during pregnancy and at a postpartum or postabortion checkup. It can be performed in a woman suspected or known to have an STI or HIV/AIDS.

**Figure 6-1** is a sample flow diagram that shows the possible options for women after VIA testing. Guidance is provided for each outcome, including when counseling is needed. For each outcome there are either simple instructions for the woman (e.g., return for VIA every 5 years) or specific issues that should be discussed with her, such as when and where treatment can be provided, the potential risks and benefits associated with treatment, and when referral for additional testing or more extensive treatment is necessary.

## **CLIENT ASSESSMENT**

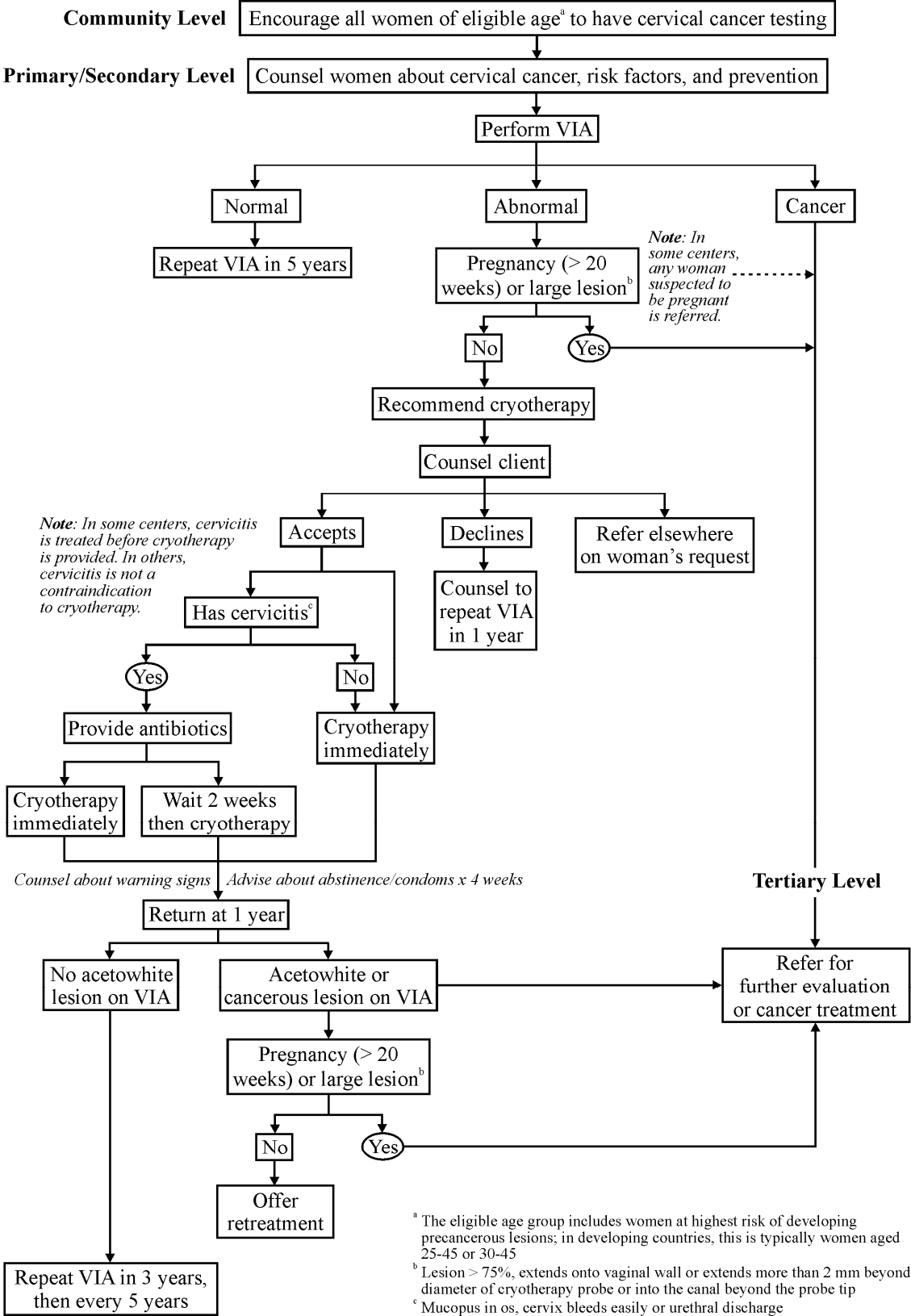
Cervical cancer testing usually is performed as part of a mass reproductive health screening program or some other primary healthcare service, such as a prenatal or postpartum visit, initiation or continuation of family planning, postabortion care, voluntary sterilization or assessment for STIs. Therefore, the brief history and limited examination outlined in this chapter should be presented in the context of the reproductive health service being provided.

Take a brief reproductive health history. It should include the following:

- Menstrual history
- Bleeding pattern (e.g., postcoital or irregular bleeding)
- Parity
- Age at first intercourse
- Use of contraceptive method

Be sure to include information on any of the cervical cancer risk factors previously mentioned. A sample record form is shown in **Figure 6-2**.

Figure 6-1. Sample Flow Diagram for Cervical Cancer Prevention



**Figure 6-2. Sample Cervical Cancer Prevention Record Form**

**REPRODUCTIVE HISTORY**

Age \_\_\_\_\_ Parity \_\_\_\_\_  Currently pregnant (weeks) \_\_\_\_\_  
 Current contraceptive \_\_\_\_\_ Age of first intercourse \_\_\_\_\_

**Menstrual Bleeding Pattern**

Regular (23–35 day interval)  
 Irregular \_\_\_\_\_  
 Postcoital spotting or bleeding

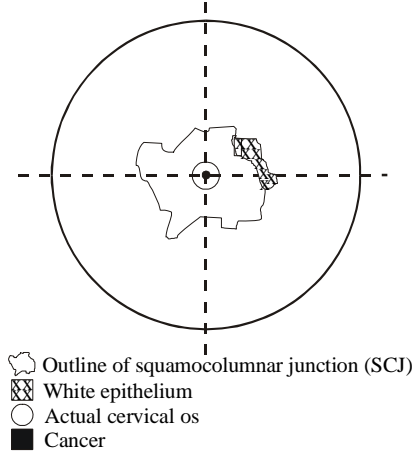
**STI History**

Number of sexual partners:  Had an STI  
 Patient \_\_\_\_\_ Patient \_\_\_\_\_  
 Spouse \_\_\_\_\_ Spouse \_\_\_\_\_

**Risk Factors**

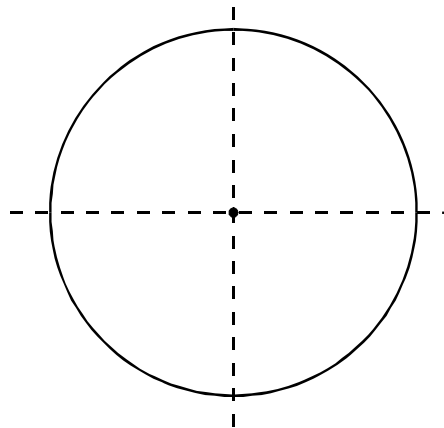
Smoker  Previous abnormal Pap smear \_\_\_\_\_  
 HIV/AIDS  Mother or sister(s) with cervical cancer \_\_\_\_\_  
 Chronic corticosteroid use \_\_\_\_\_

**Example of Cervical Map**



**EXAMINATION**

Vulva \_\_\_\_\_  
 Vagina \_\_\_\_\_  
 Cervix \_\_\_\_\_



Bimanual examination  
 Uterus \_\_\_\_\_  
 Adnexa \_\_\_\_\_  
 Rectovaginal examination  
 (if indicated) \_\_\_\_\_

**MANAGEMENT**

**Normal VIA (Test-negative)**

Counseled to return in \_\_\_\_\_ years for testing

**STI Suspected**

Treated \_\_\_\_\_  
 Referred \_\_\_\_\_

**Abnormal VIA (Test-positive)**

Counseled about cervical cancer risk and treatment options  
 Accepts recommended treatment  
 Treatment provided  
 Cryotherapy (Instructions given)  
 Other (Instructions given) \_\_\_\_\_  
 Return visit date \_\_\_\_\_

**REFERRAL**

Suspected cervical cancer  Lesion extends to vaginal wall  
 Lesion > 75%  Pregnancy (> 20 weeks)  
 Lesion > 2 mm beyond cryoprobe, including tip of probe  Referred for further testing or treatment

## **INSTRUMENTS AND SUPPLIES**

VIA can be performed in any clinic that have the following items:

- Examining table
- Light source
- Bivalve speculum (Cusco or Graves)
- Instrument tray or container

The **examining table** should allow the examiner to insert the speculum and see the cervix.

Light from a window is usually not sufficient to see the cervix, so use a **light source**, such as a goose-necked lamp or a flashlight (torch), if available. The light must be strong enough for the examiner to see the upper end of the vagina where the cervix is located. Inspection cannot be performed if there is not enough light to see the entire cervix. It is also important that the light source not be too hot. A lamp that is too hot will be uncomfortable for both the woman and the provider. A high-quality flashlight provides adequate light without too much heat. In addition, the flashlight does not require a source of electricity, is portable and can be placed in whatever position allows the best view of the cervix.

A Graves **bivalve speculum** is preferred because it is more effective at exposing the cervix, but either Cusco or Graves can be set and left open while the cervix is being examined. This leaves the provider's hands free to swab the cervix, adjust the light source and manipulate the cervix and speculum in order to see the cervix fully. A Simms speculum is not recommended because it has only one blade and has to be held by an assistant.

In addition, if cryotherapy is to be coupled with VIA testing, the necessary instruments for cryotherapy should be ready and available (see **Chapter 7**).

The few supplies needed for performing VIA should all be available locally:

- Cotton swabs
- New examination gloves or high-level disinfected surgical gloves
- New wooden spatula and/or condom
- Dilute (3–5%) acetic acid solution (clear vinegar is acceptable)
- 0.5% chlorine solution for decontaminating instruments and gloves
- A record form for recording the findings

**Cotton swabs** are used to remove mucus and discharge from the cervix and to apply acetic acid to the cervix. These swabs should be generously covered with clean cotton so that they will be able to wash the cervix thoroughly with acetic acid and not scratch or injure the cervix. The cotton swabs do not have to be sterile. Cotton “wool” formed into balls and applied to the cervix with a forceps is also acceptable.

**Examination gloves** should be new. (If surgical gloves are being reused, they should be decontaminated, cleaned and high-level disinfected after each use. Sterile gloves are not necessary.) Use a new pair of gloves for every woman.

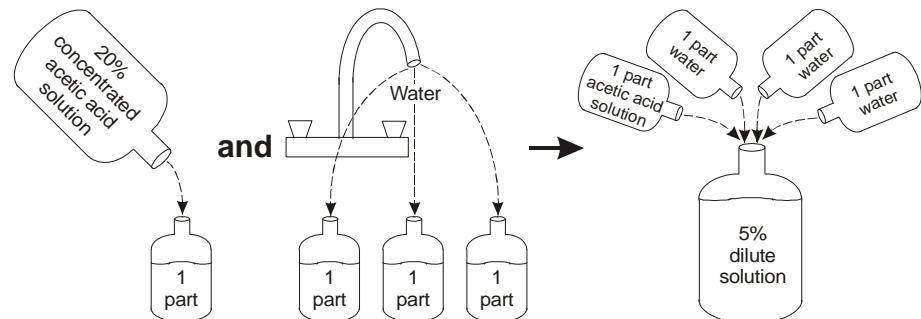
The **wooden spatula** is used to push away the lateral walls of the vagina if they protrude through the speculum blades. Use a new spatula for every woman. Alternatively, a condom with a cut tip can be rolled over the speculum blades to prevent the walls of the vagina from pushing into the space and preventing an adequate view of the cervix.

**Acetic acid** is the main ingredient of vinegar. A dilute (3–5%) solution is recommended. In some countries, vinegar is not available. Often what is sold in the market is a “vinegar-substitute” that in fact is acetic acid. If neither vinegar nor an acetic acid substitute is available, a pharmacist/chemist or local chemical supplier can make the dilute acetic acid using the following formula:

$$\text{Total Parts (TP) water} = \left[ \frac{\% \text{ Concentrate}}{\% \text{ Dilute}} \right] - 1$$

For example, to prepare a dilute solution (5%) from a 20% concentrated acetic acid solution:

$$\text{TP water} = \left[ \frac{20\%}{5\%} \right] - 1 = 4 - 1 = 3 \text{ parts water to 1 part concentrate}$$



**Chlorine solution (0.5%)** is used to decontaminate the speculum and surgical gloves after each use. After decontamination, the speculum, instrument tray or container and surgical gloves should be washed with soap and water, thoroughly rinsed and then high-level disinfected or

sterilized. (See **Appendix C** for detailed information on how to prepare chlorine solutions.)

**VISUAL INSPECTION WITH ACETIC ACID (VIA)**

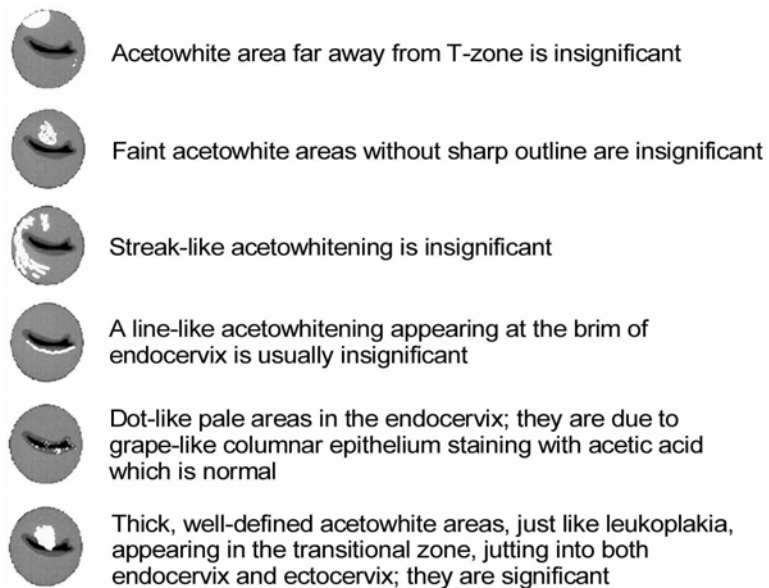
**General Procedure** To perform VIA, the provider applies a dilute acetic acid solution to the cervix. This solution shows any changes in the cells covering the cervix (epithelial cells) by producing the “acetowhite” reaction. First, the provider performs a speculum examination to see the cervix. Then, the cervix is cleaned to remove any discharge, and acetic acid is applied thoroughly to the cervix. After **at least** 1 minute the cervix, including the entire SCJ, is inspected for any acetowhite change. The results of the test (i.e., either test-positive or -negative) should be discussed with the woman, and treatment should be offered after counseling, if it is appropriate and immediately available.

**Classification of VIA Test Results** The assessment findings should be recorded using the standardized categories summarized in **Table 6-1**.

**Table 6-1. VIA Classification Relative to Clinical Findings**

VIA CLASSIFICATION	CLINICAL FINDINGS
Test-positive	Raised and thickened white plaques or acetowhite epithelium, usually near the SCJ (see <b>Figure 6-3</b> )
Test-negative	Smooth, pink, uniform and featureless; ectropion, polyp, cervicitis, inflammation, Nabothian cysts
Cancer	Cauliflower-like growth or ulcer; fungating mass

**Figure 6-3. Clinical Significance and Location of Acetowhite Lesions**



*Adapted from:* International Agency for Research on Cancer (IARC).

**Step-by-Step Instructions**     *Client Assessment and Getting Ready*

**Step 1** Before performing the VIA test, discuss the procedure with the woman. Explain why the test is recommended and exactly what will take place during the examination. Also discuss with her the nature of the most likely findings and the followup or treatment that might be required.

**Step 2** Make sure that all necessary instruments and supplies are available, including a high-level disinfected or sterile speculum, cotton swabs in a clean container, a bottle of dilute acetic acid and adequate light source. Test the light source to be sure it is working.

Bring the woman into the examination area. Ask her to empty her bladder if she has not already done so. If her hygiene is poor, have the woman thoroughly wash and rinse her genital area. Ask her to remove only enough clothing (including undergarments) so that the pelvic examination and VIA test may be performed.

**Step 3** Assist the woman with positioning herself on the examining table and drape her for the pelvic examination.

**Step 4** Wash hands thoroughly with soap and water and dry with a clean, dry cloth or air dry. Palpate the abdomen.

**Step 5** Put a pair of new examination or high-level disinfected surgical gloves on hands.<sup>1</sup>

**Step 6** Arrange the instruments and supplies on a high-level disinfected tray or container, if not already done.

*VIA Test*

**Step 1** Inspect the external genitalia and check the urethral opening for discharge. Palpate the Skene's and Bartholin's glands. Tell the woman that the speculum is about to be inserted and that she may feel some pressure.

**Step 2** Gently insert the speculum fully or until resistance is felt and slowly open the blades to reveal the cervix. Adjust the speculum so that the **entire** cervix can be seen. This may be difficult in cases where the cervix is large or extremely anterior or posterior. It may be necessary to use a clean cotton swab,

---

<sup>1</sup> If additional gloves are available, put a second glove on one hand so that when you are ready to use the light source, you can remove the outer glove and move the light source with a clean glove.

spatula or other instrument to gently push the cervix down or up into view.

**Note:** If the walls of the vagina are very lax, use a cotton swab or wooden spatula to push away any tissue protruding between the blades of the speculum. Alternatively, prior to insertion of the speculum, a condom can be rolled over the blades and the tip of the condom cut off. When the speculum is inserted and the blades are opened, the condom will prevent the walls of the vagina from pushing into the space between the blades.

**Step 3** When the cervix can be seen in its entirety, fix the blades of the speculum in the open position so that it will remain in place with the cervix in view. Doing this enables the provider to have at least one hand free.

**Note:** Throughout the procedure, it may be necessary to repeatedly adjust either the angle from which the cervix is viewed or the light source in order to achieve the best view of the cervix.

**Step 4** Move the light source so that you can see the cervix clearly.

**Step 5** Look at the cervix and check for evidence of infection (cervicitis) such as whitish purulent discharge (mucopus); ectopy (ectropion); grossly apparent tumors or Nabothian cysts, ulcers or “strawberry” lesions (*Trichomonas* infection).

**Step 6** Use a clean cotton swab to remove any discharge, blood or mucus from the cervix. Dispose of the swab by placing it in a leakproof container or plastic bag.

**Step 7** Identify the cervical os and SCJ and the area around it.

**Step 8** Soak a clean swab in dilute acetic acid solution and apply it to the cervix. If necessary, use clean swabs to repeat applications of acetic acid until the cervix has been thoroughly washed with acid. Dispose of used swab(s).

**Step 9** Once the cervix has been washed with the acetic acid solution, wait at least 1 minute, and observe the cervix for acetowhite changes.

**Step 10** Inspect the SCJ carefully. Check to see if the cervix bleeds easily. Look for any raised and thickened white plaques or acetowhite epithelium.

**Note:** The SCJ should be completely seen to determine if the cervix is normal or abnormal.

- Step 11** As needed, reapply acetic acid or swab the cervix with a clean swab to remove any mucus, blood or debris that develops during the inspection and that may obscure the view. Dispose of used swab(s).
- Step 12** When visual inspection of the cervix has been completed, use a fresh cotton swab to remove any remaining acetic acid from the cervix and vagina. Dispose of used swab(s).
- Step 13** Gently remove the speculum. If the VIA test is negative, place the speculum in 0.5% chlorine solution for 10 minutes for decontamination. If the VIA test is positive and, after counseling, the patient requests immediate treatment, place the speculum on the high-level disinfected tray or container so it can be used during cryotherapy.
- Step 14** Perform a bimanual examination and rectovaginal examination (if indicated). Check for cervical motion tenderness; size, shape and position of the uterus; pregnancy or any uterine abnormality and enlargement or tenderness of adnexa.

#### *Post-VIA Tasks*

- Step 1** Wipe the light source with 0.5% chlorine solution or alcohol to avoid cross-contamination between patients.
- Step 2** Immerse both gloved hands in 0.5% chlorine solution. Remove the gloves by turning them inside out. If disposing of the gloves, place them in a leakproof container or plastic bag. **If a rectovaginal examination was performed, gloves must be disposed of.** If reusing surgical gloves, submerge them in 0.5% chlorine solution for 10 minutes for decontamination.
- Step 3** Wash hands thoroughly with soap and water and dry them with a clean, dry cloth or air dry.
- Step 4** If the VIA test is negative, ask the woman to move toward the head of the table and help her sit up. Ask her to get dressed.
- Step 5** Record the VIA test results and other findings such as evidence of infection (cervicitis); ectropion; grossly apparent tumors; or Nabothian cysts, ulcers or “strawberry cervix.” If acetowhite change that is characteristic of a diseased cervix is present, record the cervical examination as abnormal. Draw a “map” of

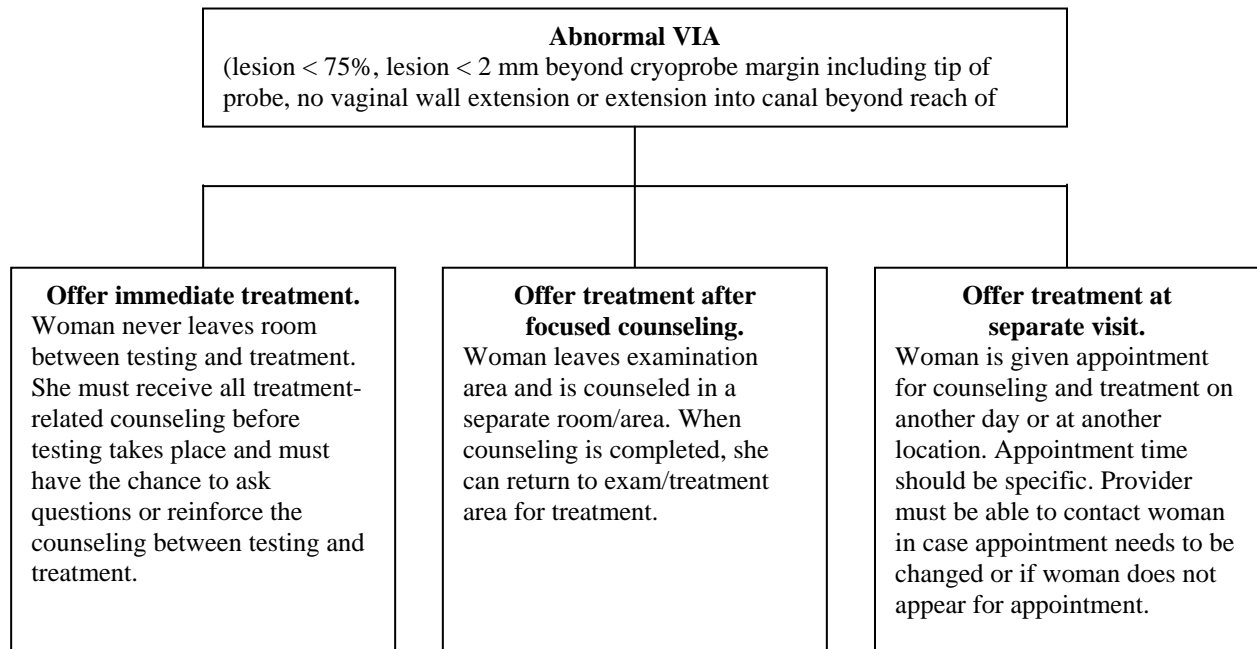
the cervix and the diseased area on the record form (see **Figure 6-2**).

**Step 6** Discuss the results of the VIA test and pelvic examination with the woman. If the VIA test is negative, tell her when to return for repeat VIA testing.

**Step 7** If the VIA test is positive or cancer is suspected, tell the woman what the recommended next steps are. If treatment is immediately available, discuss this possibility with her. If referral is required for further testing or treatment, make arrangements for the referral and provide the woman with the necessary forms and instructions before she leaves the clinic. If it is possible to make an appointment now, this is the best time.

**Note:** Linking treatment to testing may vary among programs or clinics and will be related to factors such as client flow, available resources, personnel and time. Several alternative schemes for arranging this critical linkage are outlined in **Figure 6-4**.

**Figure 6-4. Possible Links between VIA Testing and Treatment**



In all cases, especially if treatment is provided immediately, counseling must be as complete as possible to be sure that the woman makes a free and informed decision. The principles and guidelines for providing high-quality counseling are described in **Chapter 4**.

## **REFERENCES AND FURTHER READING**

Alliance for Cervical Cancer Prevention (ACCP). 2002. Cervical Cancer Prevention Fact Sheet.

[http://www.path.org/files/RH\\_visual\\_screening.pdf](http://www.path.org/files/RH_visual_screening.pdf)

Cox TJ. 1999. Management of cervical intraepithelial neoplasia. *Lancet* 353(9156): 941–943.

Kitchener HC and P Symonds. 1999. Detection of cervical intraepithelial neoplasia in developing countries. *Lancet* 353: 856–857.

Rubin MM. 1999. Cytologic concerns in adolescents: entering the transformation zone. *ADVANCE for Nurse Practitioners* 7: 53–54, 56.

Sankaranarayanan R et al 1998. Visual inspection of the uterine cervix after the application of acetic acid in the detection of cervical carcinoma and its precursors. *Cancer* 83:2150–2156.

University of Zimbabwe/JHPIEGO Cervical Cancer Project. 1999. Visual inspection with acetic acid for cervical cancer screening: Test qualities in a primary care setting. *Lancet* 353 (9156): 869–873.

## SEVEN

# TREATMENT AND FOLLOWUP

## BACKGROUND

A 1995 survey of procedures being used in developing countries to manage precancerous lesions (dysplasia or CIN) reported that hysterectomy and cone biopsy—both of which involve hospitalization and are associated with significant procedure-related costs and risks—were the most commonly used methods. Available scientific evidence, however, supports the use of several outpatient procedures (e.g., cryotherapy and LEEP) as being highly effective (Bishop, Sherris and Tsu 1995). The continued use of inpatient methods such as cone biopsy and hysterectomy that are more costly and potentially more risky to women is in part due to a lack of equipment and supplies to perform these simpler and safer procedures. It is also due in part to the fact that cervical cancer screening in some countries is not offered at lower levels of the healthcare system where outpatient treatment could be made available (see **Appendix G** for details).

**Table 7-1** shows a comparison of several methods for treating precancerous lesions.

**Table 7-1. Cervical Cancer Treatment Options**

Procedure	Outpatient	Anesthesia	Electrical Power	Nonphysicians	Cost <sup>a</sup>
Cryotherapy	Yes	No	No	Yes	Low
Electrocautery	Yes	Yes (local)	Yes	Yes	Low
Cold cautery (100°C)	Yes	Yes (local)	Yes	Yes	Low
LEEP	Yes	Yes (local)	Yes	No	Mod
Laser vaporization	Yes	Yes (local)	Yes	No	High
Cone biopsy	No	Yes (general or regional)	Yes <sup>b</sup>	No	High
Hysterectomy	No	Yes (general or regional)	Yes <sup>b</sup>	No	High

<sup>a</sup> Low = < \$500, Moderate = \$500–1500, High = > \$1500

<sup>b</sup> Required for use of operating room lighting and equipment

As discussed in **Chapter 1**, the recommended screen-and-treat approach will have the greatest program impact if it:

- can be provided at the lowest level of the healthcare system where the majority of women at risk are located,
- can take place during the same visit,
- can be provided by nurses or nurse-midwives, and

- offers excellent cure rates with a good cost-benefit ratio for treatment of lesions that have a low likelihood of being cancerous.

For most countries with limited resources, cryotherapy, either alone or in combination with LEEP (provided at a referral center), is the best outpatient option.

## OUTPATIENT TREATMENT PROCEDURES

Until recently, which of these outpatient treatment options is most effective has been disputed. A randomized clinical trial conducted by Mitchell and colleagues (1998) provides strong evidence that cryotherapy, laser vaporization and LEEP are not significantly different in effectiveness (success rates ranging from 74 to 83%). In order to reduce bias in this study, all patients were classified according to the size (area) and type (histologic grade) of the lesion.

As shown in **Table 7-2**, differences in effectiveness, persistence, recurrence and complications were not statistically significant. In addition, to more accurately determine the recurrence rate, women were followed up for a longer time than in any previous study of this type. The main factor that was associated with treatment failure was lesion size, and it was clear that when large lesions (for example, lesions that might be too large for the cryoprobe to reach) were present, all three treatment methods (cryotherapy, LEEP and laser) were more likely to fail than when smaller lesions were present.

**Table 7-2. Comparison of Treatment Options**

	<b>Cryotherapy (n = 139)</b>	<b>Laser Vaporization (n = 121)</b>	<b>LEEP (n = 130)</b>
Effectiveness (at 1 year)	76%	83%	84%
• Persistence	7%	4%	4%
• Recurrence	19%	13%	13%
Complications	2%	4%	8%
Bleeding (peri- and postoperative)	0%	1%	3%

*Source:* Mitchell et al. 1998.

In fact, when the size, type and location of the lesion were taken into account, only the association between lesion size and the rates of persistence was statistically significant. Women with lesions covering more than two-thirds of the surface of the cervix were **19 times** more likely to have persistent disease than those with smaller lesions,

regardless of the procedure used. Other factors that increased the risk of recurrence at least **two-fold** were:

- age over 30 years,
- positive HPV test (types 16 or 18), and
- previous treatment for CIN.

**Cryotherapy**

Cryotherapy involves freezing the cervix, using either compressed carbon dioxide or nitrous oxide gas as the coolant. Treatment consists of applying the coolant continuously for 3 minutes, allowing the lesion to thaw for 5 minutes, and then applying coolant for another 3- to 5-minute freeze. This procedure, called the “double freeze” technique, is easily performed without anesthesia. Cure rates are 10% better using a double versus a single freeze technique (Bryson, Lenehan and Lickrish 1985; Schantz and Thormann 1984). When performed as described, a cure rate of nearly 90% has been reported for lesions as advanced as CIN III. **Table 7-3** lists a number of studies reporting the effectiveness of cryotherapy (overall cure and CIN III cure rates). An extensive literature review on cryotherapy published in 2003 confirms its overall utility and safety (ACCP 2003).

**Table 7-3. Cryotherapy for Treatment of CIN: Key Studies with at Least 1 Year of Followup**

STUDY	NUMBER OF WOMEN	OVERALL CURE RATE (%)	CIN III CURE RATE (%)	FOLLOWUP IN YEARS
Mitchell et al. (1998)	139	76 <sup>a</sup>	N/C <sup>b</sup>	1.5 (mean)
Andersen and Husth (1992)	261	84	78	7 (mean)
Olatunbosum et al. (1992)	70	90	81	5
Berget et al. (1991)	93	96	90	2
Draeby-Kristiansen et al. (1991)	96	92	86	10
Wright and Davies (1981)	152	86	75	1 to 3.5
Hemmingson et al. (1981)	181	84	82	5 to 8

<sup>a</sup> Randomized trial differences in cure rates for cryotherapy and LEEP not statistically significant.

<sup>b</sup> Not calculated.

Source: Bishop, Sherris and Tsu 1995.

The main advantages of cryotherapy are that the equipment needed is simple, the procedure is easy to learn and the procedure does not require

local anesthesia or electricity. The procedure has few side effects (**Table 7-4**). Disadvantages of cryotherapy are that no tissue is obtained for histological confirmation of the lesion and a regular supply of liquid coolant is needed.

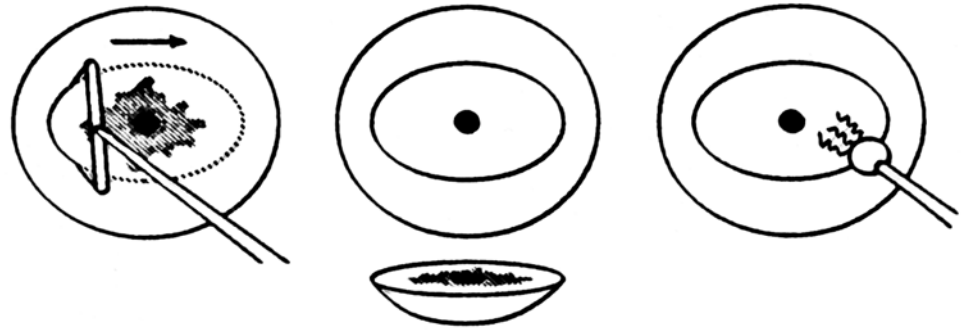
**Table 7-4. Expected Side Effects of Cryotherapy**

SIDE EFFECT	MANAGEMENT
Cramping	<ul style="list-style-type: none"> <li>• Counsel patient before the procedure that she should expect some degree of cramping during and after the procedure and that cramping usually stops shortly after the procedure.</li> <li>• Reduce cramping by pressing lightly on cervix with the cryoprobe.</li> <li>• If cramping is severe, provide oral analgesic (acetaminophen or ibuprofen).</li> </ul>
Vaginal discharge (profuse, watery)	<ul style="list-style-type: none"> <li>• Counsel patient to expect a discharge lasting up to 6 weeks.</li> <li>• Counsel patient to return if discharge changes to foul-smelling or pus-colored: evaluate for infection and treat with antibiotics.</li> <li>• Counsel patient to return for evaluation if there is heavy bleeding.</li> <li>• Strongly advise abstinence for 4 weeks.</li> <li>• If abstinence unlikely, advise condom use for 4 weeks for prevention of pelvic infection.</li> </ul>
Light bleeding or spotting	<ul style="list-style-type: none"> <li>• Counsel patient to expect light bleeding or spotting for 1–2 weeks.</li> <li>• Counsel patient to return for evaluation if there is heavy bleeding.</li> </ul>

**(LEEP) Loop Electrosurgical Excision Procedure**

Excision of cervical lesions by LEEP is done by applying a low-voltage, high-frequency alternating current to a thin wire loop electrode and slowly passing it across the cervix (Figure 7-1). Then the raw area of the cervix is cauterized using a ball-type electrode. This technique has a distinct advantage over other procedures, such as cryotherapy, because it can provide a specimen for histology. Because LEEP is a relatively new technique, there are few large studies documenting long-term success rates beyond 1 year (Table 7-5).

Figure 7-1. LEEP



Source: Bishop, Sherris and Tsu 1995; Wright, Richart and Ferenczy 1992.

Table 7-5. LEEP Success Rates

STUDY	NUMBER OF WOMEN	CIN III CURE RATE (%)	OVERALL CURE RATE (%)	FOLLOWUP IN YEARS
Mitchell et al. (1998)	130	81 <sup>a</sup>	N/C <sup>b</sup>	1.5 (mean)
Prendiville, Cullimore and Normal (1989)	102	99	97	1.5 (mean)
Gunasekera, Phipps and Lewis (1990)	98	95	95	0.5
Bigrigg et al. (1990)	659	96	96	0.3
Luesley et al. (1993)	557	96	97	0.5
Wright, Richart and Ferenczy (1992)	141	94	95	0.5
Keijser et al. (1992)	395		81	4.8 (mean)

<sup>a</sup> Randomized trial differences in cure rates for cryotherapy and LEEP not statistically significant.

<sup>b</sup> Not calculated.

Source: Bigrigg et al. 1990; Gunasekera, Phipps and Lewis 1990; Keijser et al. 1992; Luesley et al. 1993; Mitchell et al. 1998; Prendiville, Cullimore and Normal 1989; Wright, Richart and Ferenczy 1992.

A disadvantage of LEEP is that local anesthesia (paracervical block) is required to minimize discomfort. Also, the equipment, consisting of an electrosurgical generator, smoke evacuating system and disposable wire loops (reusable loops are available but have a limited number of reuses), is expensive. The procedure has few side effects; the main complication is a 3% perioperative bleeding rate (Mitchell et al. 1998).

**Electrocautery** Electrocautery of the cervix is performed by providing passive transfer of heat from a hot probe to the tissue. Older electrocautery units used a “spark-gap” type electrode to burn and destroy cervical tissue. This causes both intense uterine cramping and considerable heat transfer to the vagina, which is extremely painful and requires the use of local anesthesia (paracervical block) and analgesics. A recent innovation, the Semm “cold coagulator,” which employs a different method of heat transfer, has been used in Europe and causes minimal pain. The effectiveness of this new procedure, however, has been evaluated for only a short time and the equipment is not widely available. Consequently, it is not recommended for use in low-resource settings. The overall success rate with this technique is greater than 90% (Gordon and Duncan 1991; Loobuyck and Duncan 1993).

**Table 7-6** summarizes the advantages and disadvantages of cryosurgery, LEEP and electrocautery.

**Table 7-6. Comparison of Treatment Modalities**

TREATMENT	ADVANTAGES	DISADVANTAGES
<b>Cryotherapy</b>	<ul style="list-style-type: none"> <li>• Effective with small- and moderate-sized lesions (85–95% cure rate)</li> <li>• Inexpensive</li> <li>• Nonphysician can perform</li> <li>• No local anesthesia required</li> <li>• No electricity required</li> <li>• Associated with few complications/ side effects</li> <li>• Can be performed during pregnancy</li> </ul>	<ul style="list-style-type: none"> <li>• Variable success rate with large lesions (75–85% cure rate)</li> <li>• Destructive (leaves no tissue sample for confirmatory diagnosis)</li> <li>• Difficult to determine exact amount of tissue destroyed</li> <li>• Associated with profuse watery discharge for up to 6 weeks following treatment</li> <li>• Requires access to and resupply of coolant (CO<sub>2</sub> or N<sub>2</sub>O)</li> </ul>
<b>LEEP</b>	<ul style="list-style-type: none"> <li>• Effective (80–96% cure rate for all lesions)</li> <li>• Enables tissue sampling for diagnosis</li> <li>• Associated with few complications/ side effects</li> </ul>	<ul style="list-style-type: none"> <li>• Equipment is more expensive than cryotherapy</li> <li>• Primary side effect is peri- and postoperative bleeding (about 3–8%)</li> <li>• Requires physician to perform it</li> <li>• Requires local anesthesia</li> <li>• Requires electricity (but could be battery powered)</li> <li>• Requires resupply of loops</li> <li>• Should not be performed during pregnancy</li> </ul>

*(table continued on next page)*

**Table 7-6. Comparison of Treatment Modalities (continued)**

<p><b>Electrocautery</b></p>	<ul style="list-style-type: none"> <li>• Effective with mild and moderate lesions (90% cure rate)</li> <li>• Inexpensive</li> <li>• Sturdy equipment</li> <li>• Associated with few complications/side effects</li> </ul>	<ul style="list-style-type: none"> <li>• Variable success rate with large, severe lesions (85–95% cure rate)</li> <li>• Destructive (leaves no tissue sample for confirmatory diagnosis)</li> <li>• Difficult to determine exact amount of tissue destroyed</li> <li>• Associated with watery discharge for up to 6 weeks following treatment</li> <li>• Requires local anesthesia</li> <li>• Requires electricity (but could be battery powered)</li> <li>• Equipment not widely available</li> <li>• Should not be performed during pregnancy</li> </ul>
------------------------------	---	--

Although it is clear that all of these treatment options can be safe and effective, the qualities of cryotherapy make it most attractive to low-resource settings, especially where nurses will be expected to provide a significant proportion of the preventive services.

**CRYOTHERAPY TREATMENT AND REFERRAL**

Women who are VIA test-positive, including women who are less than 20 weeks pregnant<sup>1</sup>, are eligible for cryotherapy treatment if the lesion:

- is not suspicious for cancer,
- occupies less than 75% of the cervix,
- does not extend onto the vaginal wall or into the cervical canal beyond the reach of the cryoprobe, and
- extends less than 2 mm beyond the diameter of the cryotherapy probe including the tip of the probe.

If any of the above conditions are not met, refer the woman to an appropriate facility where additional diagnostic and treatment methods are possible and medical backup is available (**Table 7-7**). In addition, HIV-positive women who have dysplastic lesions should be counseled that any outpatient treatment might be less effective. Because lesions may progress more rapidly in HIV-positive women despite treatment, use of antiretroviral agents or antimetabolite gels or cremes, such as 5-fluorouracil, in combination with cryotherapy or LEEP, may reduce the risk of recurrence (Maiman et al. 1999).<sup>2</sup>

<sup>1</sup> Women who are less than 20 weeks (5 months) pregnant **can** be eligible for cryotherapy because this procedure has not been associated with a risk of peri- or post-treatment bleeding.

<sup>2</sup> If the woman is known to be HIV-positive, she should return in 6 months.

**Table 7-7. Recommended Referral Actions**

VIA FINDING	REFERRAL ACTION
Women suspected of having cervical cancer	Refer immediately to a facility that can adequately provide treatment for invasive cancer.
Test-positive women whose lesions occupy greater than 75% of the cervix, extend into the vaginal wall or extend more than 2 mm beyond the cryotherapy probe including the tip of the probe	Refer for assessment and treatment at the nearest facility offering LEEP or cone biopsy. If travel to the other facility is not possible or judged not likely to happen, then counsel about the greater likelihood of persistence of the lesion at 12 months and the need for retreatment.
Test-positive women who fulfill criteria for immediate treatment but who request to be treated using a procedure other than cryotherapy	Counsel about advantages and disadvantages of all treatment methods. Refer to closest facility offering treatment of their choice.
Test-positive women who request further (more diagnostic) testing, not offered at the site	Refer to closest facility offering colposcopy and biopsy (as indicated).
Test-positive women declining any treatment	Counsel about the likelihood of disease progression and prognosis. Recommend a return visit within a year for a repeat VIA test to reassess disease status.

Once a woman is assessed as eligible for treatment, the healthcare provider should explain to her the meaning and implications of the test results. Next, s/he should explain in more detail what the treatment procedure involves, including the benefits, risks, potential side effects and their management, and advantages and disadvantages of immediate treatment. Then the woman should make an informed choice regarding treatment. Her verbal or written consent (consistent with local norms) and choice of treatment should be recorded where indicated on the report form (**Figure 6-2**, page 6-4). Next, she should be shown a comfortable place to sit until cryotherapy can be performed. Waiting time for treatment should not be longer than 1–2 hours.

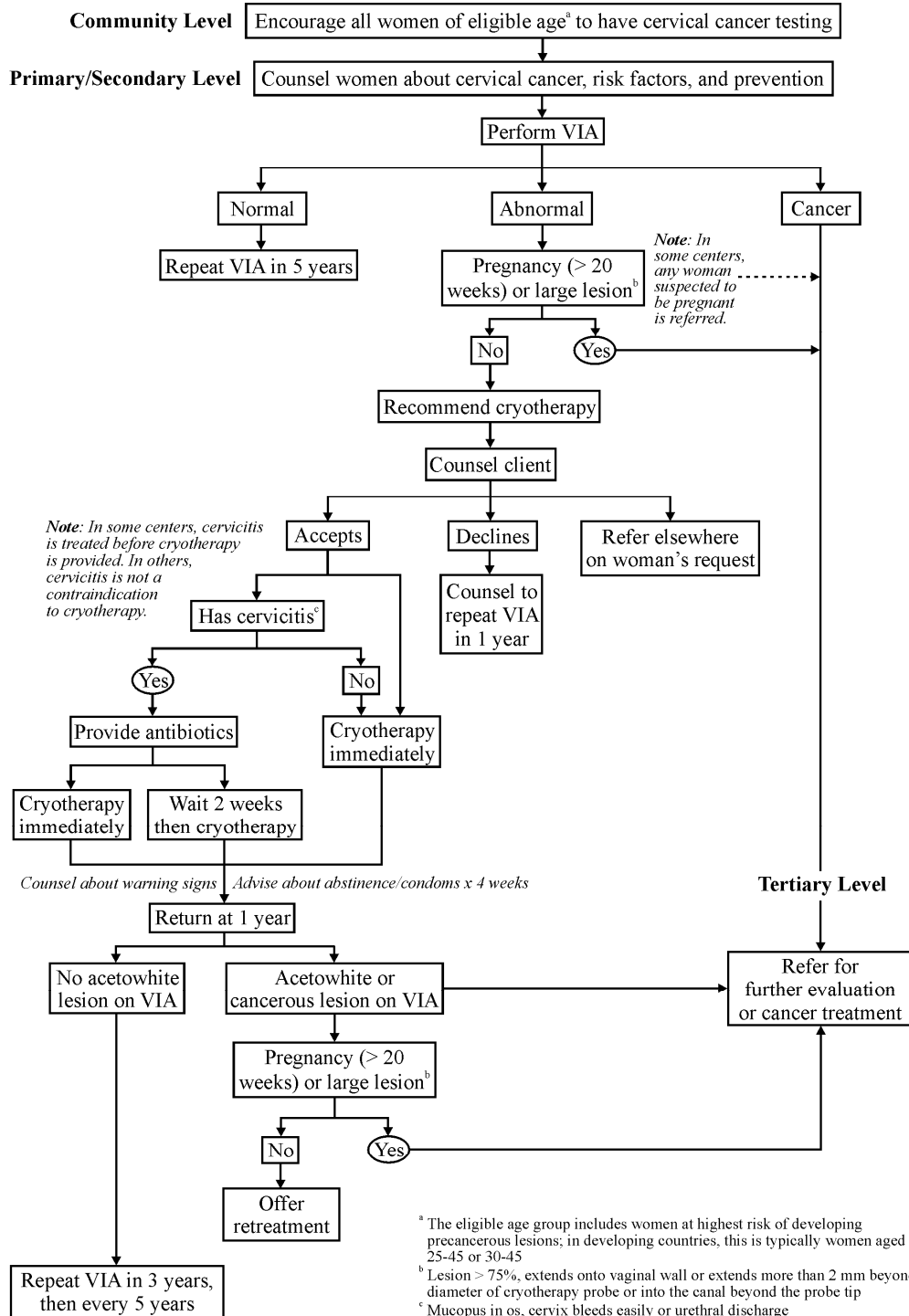
Women assessed as test-positive who have evidence of purulent cervicitis<sup>3</sup> can be given a **single oral dose** of two antibiotics (1 g azithromycin for *Chlamydia trachomatis*<sup>4</sup> and 250 mg ciprofloxacin for *Neisseria gonorrhoeae*) prior to cryotherapy. They can be offered the choice of either having cryotherapy immediately (the same day as taking antibiotics) or returning in 2 weeks after antibiotic treatment for repeat VIA and cryotherapy. Providing antibiotic treatment to women suspected of having purulent cervicitis may potentially reduce the very small risk (less than 1%) of pelvic infection following cryotherapy.

<sup>3</sup> Purulent cervicitis is defined as yellowish mucopus in the cervical os or canal, a cervix that is beefy red and bleeds easily when touched, or a urethral discharge.

<sup>4</sup> Doxycycline (100 mg orally, 2 times daily for 7 days) is an acceptable alternative, but compliance is poor. Doxycycline should not be used in pregnancy.

**Figure 7-2** is a sample flow diagram summarizing the possible options for women after VIA testing. It also shows the treatment options for VIA test-positive women.

**Figure 7-2. Sample Flow Diagram for Cervical Cancer Prevention**



## **INSTRUMENTS AND EQUIPMENT**

Cryotherapy can be performed in any clinic having the following items:

- Examining table
- Adequate light source
- Bivalve speculum (CUSCO or Graves)
- Instrument tray or container
- Cryotherapy unit
- Regular supply of compressed carbon dioxide or nitrous oxide gas

The **examining table** should allow the examiner to insert the speculum and look at the cervix.

Light from a window is usually not sufficient to see the cervix, so use a **light source**, such as a goosenecked lamp or a flashlight (torch), if available. The light must be strong enough for the examiner to see the upper end of the vagina where the cervix is located. Inspection cannot be performed if there is not enough light to see the cervix. It is also important that the light source not be too hot. A lamp that is too hot will be uncomfortable for both the woman and the provider. A high-quality flashlight provides adequate light without too much heat. In addition, the flashlight does not require electricity, is portable and can be placed in whatever position allows for the best view of the cervix.

A Graves **bivalve speculum** is preferred because it has a slightly wider opening (so the cryoprobe can fit through), but both the Graves and the Cusco specula can be set and left open while the cervix is being examined or treated. This leaves the provider's hands free to swab the cervix, adjust the light source and manipulate the cervix and speculum in order to see it fully. A Simms speculum is not recommended.

The **cryotherapy system**<sup>5</sup> (**Figure 7-3**) enables high-pressure compressed gas to travel from the gas cylinder into the expansion/freezing chamber of the cryoprobe. The system consists of the following:

- Metal cryotip with plastic sleeve, designed to fit up against the cervix and completely cover the areas surrounding the SCJ and diseased areas;
- Hand-held cryotherapy unit (or “cryogun” or “cryoprobe”), which includes the handle, freeze and defrost triggers, and insulated probe;
- Flexible hose connecting the regulator to the cryotherapy unit; and

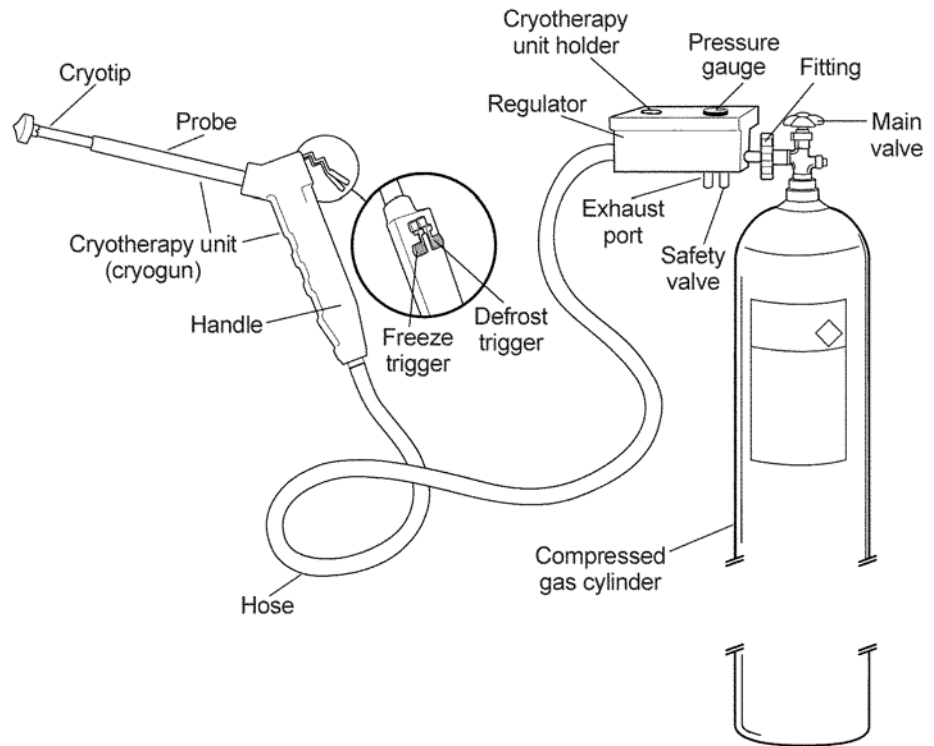
---

<sup>5</sup> In this manual, illustrations and instructions specifically related to the cryotherapy system/unit are based on the Wallach LL100 Cryotherapy System. See also Note on page 7-13.

- Regulator with pressure gauge, cryotherapy unit holder, safety valve, and exhaust port.

The cryotherapy unit is designed to connect to a compressed gas cylinder. A **timer** with a second hand also is desirable.

**Figure 7-3. Cryotherapy System<sup>6</sup>**



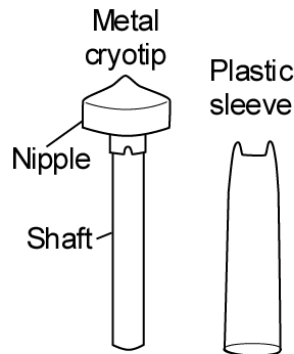
Either compressed liquid **carbon dioxide** or **nitrous oxide** gas is used as the coolants to freeze and destroy the cells of the cervix. Carbon dioxide is a common, inexpensive and safe gas costing about 50% less than nitrous oxide. It should be used “bone dry” or “medical grade” because contaminants affect the freezability of the cryosurgical equipment. Nitrous oxide has a lower freezing temperature (average  $-89^{\circ}\text{C}$  [ $-128.2^{\circ}\text{F}$ ] versus  $-68^{\circ}\text{C}$  [ $-90.4^{\circ}\text{F}$ ] for carbon dioxide) and, therefore, takes somewhat less time for treatment. The minimum working pressure shown on the gauge should be 40–70 kg per square centimeter ( $\text{kg}/\text{cm}^2$ ). The minimum temperature at the probe tip for effective freezing should be at least  $-60^{\circ}\text{C}$  ( $-76^{\circ}\text{F}$ ). For more information about choosing an appropriate gas cylinder, see **Figure D-2** on page D-2.

Cryoguns are designed to be used with a variety of cryotips. An exocervical cryotip, which has a circular end (about 19 mm in diameter) with a raised “nipple,” is recommended for use when providing cervical

<sup>6</sup> There are two types of fittings used to connect the regulator to the gas cylinder. In this picture, the United States (US) fitting is shown. A British fitting may also be used. For more information about the US and British fittings, see **Appendix D** on pages D-3 and D-4.

cancer treatment (**Figure 7-4**). Clear plastic protective sleeves, which prevent the shaft of the cryotip from contacting and freezing vaginal tissue, are provided with some cryotherapy units.

**Figure 7-4. Cryotip and Protective Sleeve**



**Supplies** The **supplies** needed to perform cryotherapy are the same as those needed for VIA:

- Cotton swabs
- New examination gloves or high-level disinfected surgical gloves
- New wooden spatula
- Dilute (3–5%) acetic acid (white vinegar is acceptable)
- 0.5% chlorine solution for decontaminating instruments and gloves
- A record form

**Cotton swabs** are used to wipe the cervix and remove mucus or discharge before performing cryotherapy. These swabs should be generously covered with clean cotton so that they will not scratch or injure the cervix. The cotton swabs do not have to be sterile.

**Examination gloves** should be new. (If surgical gloves are being reused, they should be high-level disinfected after each use. Sterile gloves are not necessary.) Use a new pair of gloves for every patient.

A **wooden spatula** is used to protect the lateral walls of the vagina from the cryotip, particularly in patients who have very lax vaginal walls. Use a new wooden spatula for each patient.

**Chlorine solution (0.5%)** is used to decontaminate the speculum and surgical gloves after each use. After decontamination, the speculum, instrument tray or container, and surgical gloves should be washed thoroughly with soap and water, thoroughly rinsed and then high-level disinfected or sterilized. (See **Appendix C** for detailed information on how to prepare the chlorine solution.)

## CRYOTHERAPY PROCEDURE

**General Procedure** First, a vaginal speculum is inserted to look at the cervix. Once the lesion has been identified, the healthcare provider places the tip of the cryoprobe against the cervix, covers the entire lesion, and applies gentle pressure. The “trigger” of the cryotherapy instrument is depressed and locked in place, allowing the coolant gas to flow to the tip. The healthcare provider freezes the cervical lesion with applying the coolant continuously for 3 minutes, allows the lesion to thaw for 5 minutes and then applies the coolant for another 3 minutes. For maximum effectiveness, the ice ball forming on the cervix should be at least 4 mm thick and extend outside the lesion by 3–5 mm.

**Note:** The following instructions are modeled on the use of a Wallach LL100 Cryotherapy System.<sup>7</sup> While the principles of cryotherapy are the same regardless of the system used, other systems may differ in appearance, operating features, and procedures for proper use. **Appendix D** contains additional information for using the LL100 Cryotherapy System—including preparing for use, performing the freeze-clear-freeze technique, and post-procedure processing. **Appendix E** provides guidance for troubleshooting problems commonly encountered when using the LL100 Cryotherapy System.

### Step-by-Step Instructions

#### *Client Assessment and Getting Ready*

- Step 1** Prior to performing cryotherapy, discuss the procedure with the patient. Explain why the treatment is necessary, what the alternatives to cryotherapy treatment are and why abstinence (or use of condoms) is important following the procedure. Tell her about the steps of the procedure, the loud sound emitted by the equipment, any discomfort she may feel and the side effects she will encounter after the procedure. If she is pregnant, be sure she is less than 20 weeks gestation.
- Step 2** Make sure that all necessary instruments and supplies are available. This includes a high-level disinfected speculum, cotton swabs in a clean container, a bottle of dilute acetic acid, a wooden spatula and adequate light source (test the light source to be sure it is working). The gas should be turned on at the master cylinder valve and the pressure should read at least 40–70 kg/cm<sup>2</sup>. Finally, the timer, if available, should be set to zero.
- Step 3** Insert a high-level disinfected cryotip into the clear plastic protective sleeve. Align the small plastic tabs on the sleeve with

<sup>7</sup>Wallach Surgical Devices, Inc., 235 Edison Road, Orange, CT 06477, USA. [www.wallachsd.com](http://www.wallachsd.com).

the slots beneath the nipple of the cryotip and firmly secure them in position.

- Step 4** Remove the protective cover from the end of the probe.
- Step 5** Before bringing the patient into the examination/procedure area, be sure she has emptied her bladder if it has been more than 30 minutes since the VIA test. Ask her to undress only from the waist down. Following this, help her onto the examining table and drape her for the procedure.
- Step 6** Wash hands thoroughly with soap and water and dry with a clean, dry cloth or air dry. Then, put one pair of new examination or high-level disinfected surgical gloves on both hands.<sup>8</sup>
- Step 7** Arrange the instruments and supplies on a high-level disinfected tray or container, if not already done.

### *Cryotherapy Procedure*

- Step 1** Tell the woman that the speculum is about to be inserted and that she may feel some pressure.
- Step 2** Gently insert the speculum fully or until resistance is felt and slowly open the blades to see the cervix. Adjust the speculum so that the **entire** cervix can be seen. This may be difficult in cases where the cervix is large, parous, patulous or extremely anterior or posterior. It may be necessary to use a clean cotton swab, spatula or forceps to gently push the cervix down or up into view.
- Step 3** When the cervix can be seen in its entirety, fix the blades of the speculum in the open position so that it will remain in place with the cervix in view. This enables the provider to have at least one hand free.
- Step 4** Move the light source so that you can see the cervix clearly.
- Step 5** Use a cotton swab to remove any discharge, blood or mucus from the cervix. Identify the cervical os, the SCJ, and the site and size of the lesion. If necessary, apply acetic acid so that the lesion can be seen. Dispose of the swab by placing in a leakproof container or plastic bag.

---

<sup>8</sup> If additional gloves are available, put a second glove on one hand so that when you are ready to use the light source, you can remove the outer glove and move the light source with a clean glove.

**Step 6** Point the probe at the ceiling. Press the freeze trigger for 1 second and then the defrost trigger for 1 second to blow gas out through the thin metal tube.

**Note:** Tell the patient that she will hear the sound of the cryotherapy unit.

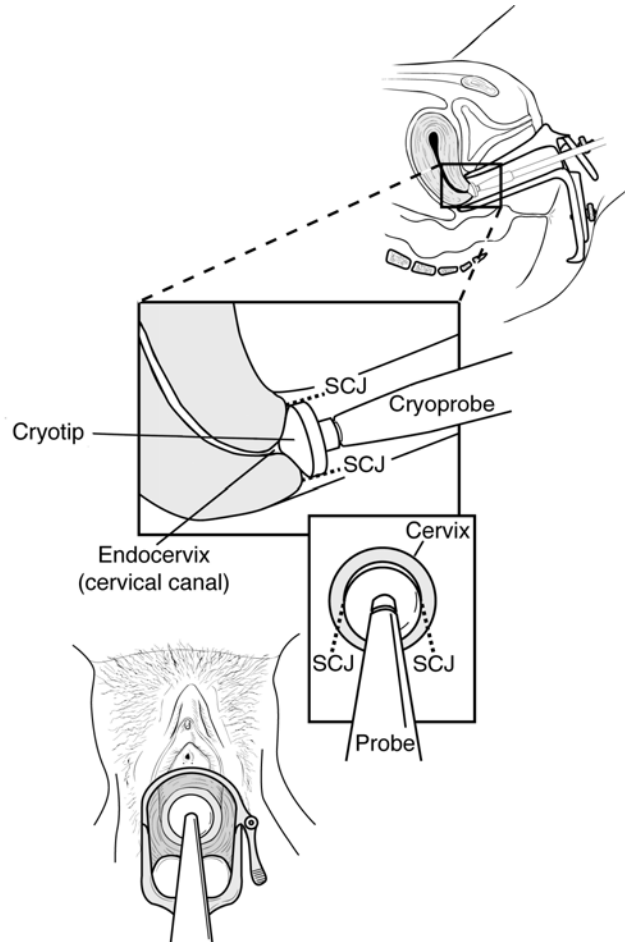
**Step 7** Screw the cryotip with sleeve onto the end of the probe. Tighten it with your hands only. Do not use any tools to tighten the cryotip onto the probe.

**Note:** If the cryotip will not attach to the probe correctly, check that the sleeve tabs are properly inserted into the slots on the cryotip.

**Step 8** Apply the cryotip to the cervix, ensuring that the nipple is centered and placed squarely onto the os (**Figure 7-5**). It is not necessary to grasp the cervix with a tenaculum or forceps. Be sure that the lateral vaginal walls are not in contact with the cryotip. Remind the woman that the unit will make noise during the procedure.

**Note:** It may be necessary to use a wooden spatula to push away any tissue protruding from between the blades of the speculum. Alternatively, before inserting the speculum, a condom can be rolled over the blades and the tip of the condom cut off. When the speculum is inserted and the blades are opened, the condom will prevent the walls of the vagina from pushing into the space between the blades.

**Figure 7-5. Applying the Cryotip to the Cervix**



**Step 9** Hold the cryogun perpendicular to the plane of the cervix. Press the freeze trigger to start the freezing process. Set the timer for 3 minutes. Be sure to apply pressure to the cervix as the gas begins to flow to the cryoprobe. Watch as the ice ball develops at and around the cryotip.

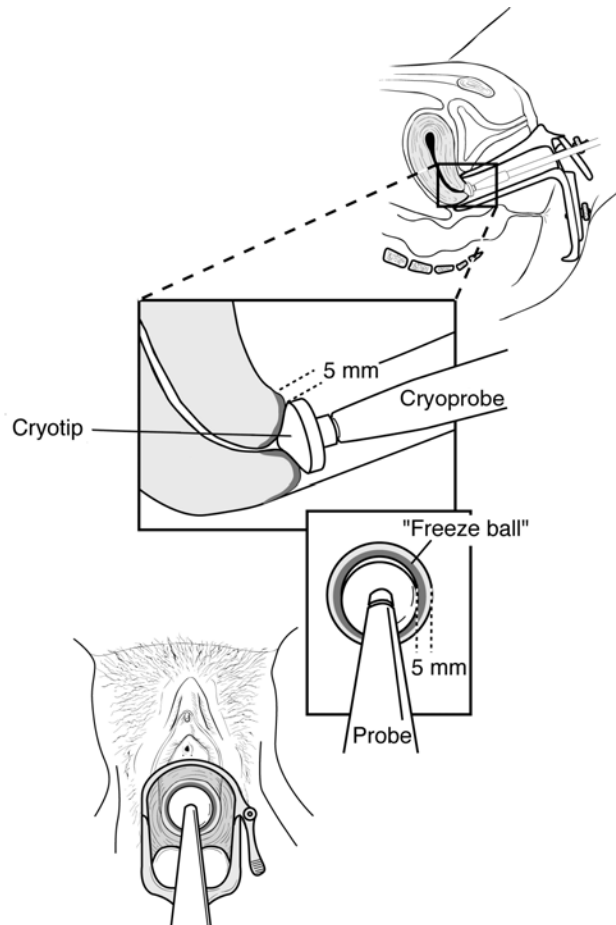
**Step 10** Use the “freeze-clear-freeze” technique. After 15 seconds, press the defrost trigger for no longer than 1 second. Immediately press the freeze trigger again. Press the defrost trigger every 15 seconds during the 3 minutes of freezing. If possible, have an assistant say “clear” every 15 seconds. (See **Note** below.)

**Note:** When CO<sub>2</sub> is used as the coolant, it is important to use this “**freeze-clear-freeze technique**” during the entire freeze time. If it is done correctly, this technique will not adversely affect the freezing of cervical tissue, but will prevent the cryotherapy unit from becoming clogged with ice during the procedure. If a provider waits for more than 15 seconds to press the defrost trigger, the unit may become clogged later during the procedure. Puffs of white gas or small pieces of ice may come out of the exhaust port; this means that the unit is removing ice from the hose. If the unit becomes clogged, follow steps for clearing the ice (see **Appendix D**, page D-5).

**Step 11** After 3 minutes of freezing, the cryotip will be attached to the cervix by the ice ball. Do not pull the cryotip off. Wait for it to defrost and detach itself from the cervix. (This usually takes less than 30 seconds.)

**Step 12** Wait 5 minutes and repeat the freezing procedure using the freeze-clear-freeze technique. It may be necessary to increase the freeze time up to 5 minutes if the ice ball is not 4 mm beyond the lateral edges of the probe (**Figure 7-6**).

**Figure 7-6. Freezing Process with Cryotherapy Unit**



**Note:** During the cryotherapy procedure, the cylinder will become cold, and moisture may form on the outside of the cylinder and hose. In addition, the pressure gauge will show a drop in pressure. All of these changes are normal. If the pressure gauge, however, shows that the pressure is below 50 kg/cm<sup>2</sup>, stop performing cryotherapy. Wait until the cylinder returns to room temperature and the gas pressure rises above 50 kg/cm<sup>2</sup>. Also, white grains of ice may come out of the exhaust port. This is normal and will not interfere with the operation of the cryotherapy unit.

**Step 13** At the end of the procedure inspect the cervix carefully to insure that a hard, white, completely frozen “iceball” is present. If not, repeat steps 9–11 at least once putting more pressure on the cervix. Ensure that adequate pressure is displayed on the gauge attached to the cryotherapy unit. If pressure is inadequate, arrange for gas resupply and reschedule the procedure.

**Step 14** After the procedure, close the master cylinder valve.

**Step 15** Inspect the cervix for any bleeding. If there is bleeding, apply pressure to the area using a clean cotton swab. Dispose of swab(s).

**Step 16** Remove the speculum and place in a 0.5% chlorine solution for 10 minutes for decontamination.

#### *Postcryotherapy Tasks*

**Step 1** Wipe the light source with 0.5% chlorine solution or alcohol to avoid cross-contamination between patients.

**Step 2** Immerse both gloved hands in 0.5% chlorine solution. Remove gloves by turning inside out. If disposing of gloves, place in leakproof container or plastic bag. If reusing surgical gloves, submerge in 0.5% chlorine solution for 10 minutes for decontamination.

**Step 3** Wash hands thoroughly with soap and water and dry with clean, dry cloth or air dry.

**Step 4** Check that the woman is not having excessive cramping before she sits up, gets off the examining table and gets dressed. If severe cramping persists beyond 5–10 minutes, give her an oral analgesic (acetaminophen or ibuprofen).

- Step 5** Advise the woman regarding post-treatment care, warning signs and followup schedule.
- Step 6** Record her results of the treatment and when the patient is scheduled to return for followup in the patient's record.
- Step 7** Observe the woman for at least 15 minutes. Ask her how she feels before sending her home.
- Step 8** Follow the instructions in **Appendix D** (page D-6) for processing the cryotherapy unit after use.

## ROUTINE FOLLOWUP

**Patient Instructions** Most women will not experience problems following cryotherapy. Advise the woman to expect some mild cramping and a clear (or lightly blood-stained) watery discharge that usually lasts for up to 6 weeks. If it becomes foul-smelling or pus-colored, or if she has pain, she should return to the clinic immediately to check for possible infection.

Advise the woman that she should not douche, use vaginal tampons or have sexual intercourse for 4 weeks, or until the discharge is completely gone.<sup>9</sup>

**Note:** If the woman will not be able to abstain from sexual intercourse, tell her to use condoms with every act of intercourse. Provide her with 15–20 condoms.

Advise her regarding the followup schedule and warning signs (**Figure 7-7**).

### **Figure 7-7. Warning Signs**

If you have any of the following, you should return to this or the nearest health facility:

- Fever for more than 2 days
- Severe lower abdominal pain, especially if you have a fever
- Bleeding heavier than your heaviest days of menstrual bleeding for more than 2 days
- Bleeding with clots

---

<sup>9</sup> Because women who are seropositive for HIV may have increased shedding of the HIV following treatment and during the healing process, and because during this period women may be more likely to acquire HIV if exposed, abstinence for up to 4 weeks is strongly recommended for all women.

Schedule a followup appointment for 1 year after the procedure, and give the woman the name of the service center or clinic to which she should return. If possible this information should be provided in writing. Finally, the woman should be given a last opportunity to ask any questions she might have.

**Followup** The woman should return for a repeat VIA testing in 1 year. At this visit, after obtaining a history of any problems, the VIA test should be done and any abnormalities noted. Because the SCJ may not be visible, the cervix should be carefully checked to assess how it has healed and whether any lesion persists. Criteria for retreatment or referral at this visit are listed in **Table 7-8**.

**Table 7-8. Treatment Status and Recommended Action**

VIA CLASSIFICATION	DESCRIPTION	RECOMMENDED ACTION
VIA Test-Negative	SCJ visible No acetowhite lesion	Repeat VIA test in 3 years (if test negative then, every 5 years)
Persistent	VIA test-positive <sup>a</sup> , but lesion(s) less than 75% of surface area of cervix	Treat again with cryotherapy
Progressed	VIA test-positive with larger lesion(s) than when treated or now covering more than 75% of the surface area	Refer to center or nearest facility offering other diagnostic and treatment options
Other Referral	Persistent lesions that qualify for retreatment with cryotherapy, but patient requests referral for a different method of treatment	Counsel again about advantages and disadvantages of all treatment methods; refer to nearest facility where treatment of choice is offered

<sup>a</sup> Acetowhite lesion present regardless of whether SCJ is visible.

**REFERENCES**

Alliance for Cervical Cancer Prevention (ACCP). 2003. *Effectiveness, Safety, and Acceptability of Cryotherapy: A Systematic Literature Review*. Cervical Cancer Prevention Issues in Depth #1. ACCP. [http://www.path.org/files/RH\\_cryo\\_white\\_paper.pdf](http://www.path.org/files/RH_cryo_white_paper.pdf)

Andersen ES and M Husth. 1992. Cryosurgery for cervical intraepithelial neoplasia: 10-year followup. *Gynecological Oncology* 45: 240–242.

Berget A, B Andreasson and JE Bock. 1991. Laser and cryosurgery for cervical intraepithelial neoplasia. *Acta Obstetrica et Gynecologica Scandinavica* 70: 231–235.

Bigrigg MA et al. 1990. Colposcopic diagnosis and treatment of cervical dysplasia in one visit. *Lancet* 336: 229–231.

Bishop A, J Sherris and VD Tsu (eds). 1995. *Cancer Dysplasia Treatment in Developing Countries: A Situation Analysis*. PATH: Seattle, Washington.

Bryson SCP, P Lenehan and GM Lickrish. 1985. The treatment of grade III cervical intraepithelial neoplasia with cryotherapy: An 11-year experience. *American Journal of Obstetrics and Gynecology* 151: 201–206.

Draeby-Kristiansen J et al. 1991. Ten years after cryosurgical treatment of cervical intraepithelial neoplasia. *American Journal of Obstetrics and Gynecology* 165(1): 43–45.

Gordon H and I Duncan. 1991. Effective destruction of cervical intraepithelial neoplasia (CIN) 3 at 100 degrees using the Semm cold coagulator: 14 years' experience. *British Journal of Obstetrics & Gynecology* 98: 14–20.

Gunasekera PC, JH Phipps and BV Lewis. 1990. Large loop excision of the transformation zone (LLETZ) compared to carbon dioxide laser in the treatment of CIN: A superior mode of treatment. *British Journal of Obstetrics & Gynecology* 97: 995–998.

Hemmingson E, U Stendahl and S Stenson. 1981. Cryosurgical treatment of cervical intraepithelial neoplasia with followup of five to eight years. *American Journal of Obstetrics and Gynecology* 139(2): 144–147.

Keijser KGG et al. 1992. Diathermy loop excision in the management of cervical intraepithelial neoplasia: Diagnosis and treatment in one procedure. 1992. *American Journal of Obstetrics and Gynecology* 166(4):1281–1287.

Loobuyck H and I Duncan. 1993. Destruction of CIN 1 and 2 with the Semm cold coagulator: 13 years' experience with the see-and-treat policy. *British Journal of Obstetrics & Gynecology* 100: 465–468.

Luesley DM et al. 1993. Loop diathermy excision of the cervical transformation zone in patients with abnormal cervical smears. *British Medical Journal* 300: 1690–1693.

Maiman M et al. 1999. Vaginal 5-fluorouracil for high-grade cervical dysplasia in human immunodeficiency virus infection: a randomized trial. *Obstetrics & Gynecology* 94(6): 954–961.

Mitchell MF et al. 1998. A randomized clinical trial of cryotherapy, loop electrosurgical excision for treatment of squamous intraepithelial lesions of the cervix. *Obstetrics & Gynecology* 92: 737–744.

Olatunbosun OA, FE Okonofua and SO Ayangade. 1992. Outcome of cryosurgery for cervical intraepithelial neoplasia in a developing country. *International Journal of Gynecology & Obstetrics* 38: 305–310.

Prendiville W, J Cullimore and S Normal. 1989. Large loop excision of the transformation zone (LLETZ). A new method of management for women with cervical intraepithelial neoplasia. *British Journal of Obstetrics & Gynecology* 96:1054–1060.

Schantz A and L Thormann. 1984. Cryosurgery for dysplasia for the uterine ectocervix. *Acta Obstetrica et Gynecologica Scandinavica* 63: 417–420.

Wright TC, RM Richart and A Ferenczy. 1992. *Electrosurgery for HPV-Related Diseases of the Lower Genital Tract: A Practical Handbook for Diagnosis and Treatment by Electroexcision and Fulguration Procedures*. BioVision Inc.: Montreal, and Arthur Vision, Inc.: New York.

Wright VC and EM Davies. 1981. The conservative management of cervical intraepithelial neoplasia: The use of cryosurgery and the carbon dioxide laser. *British Journal of Obstetrics & Gynecology* 88: 663–668.

**APPENDIX A**

**TESTS FOR CERVICAL CANCER SCREENING**

<b>DEFINITION/ MECHANISM OF ACTION</b>	<b>PROCEDURE</b>	<b>BENEFITS</b>	<b>LIMITATIONS</b>
<p><b>Automated Pap Smear</b></p> <p>Uses highly sophisticated computer “neural network” approach whereby computer can rapidly screen cells on a slide and, according to criteria provided, identify abnormal cells. These areas are then reviewed by a cytotechnician/pathologist on a monitor.</p> <p>Used as adjunct test and/or used for primary screening</p> <p>Results usually reported as:</p> <ul style="list-style-type: none"> <li>● Normal</li> <li>● Inflammation</li> <li>● Atypical Cells of Uncertain Significance (ASCUS)</li> <li>● LGSIL</li> <li>● HGSIL</li> <li>● Cancer</li> </ul>	<p>Procedure is described to woman</p> <ul style="list-style-type: none"> <li>● Reason for test</li> <li>● Procedure (what to expect)</li> <li>● Followup</li> </ul> <p>Insert the speculum</p> <p>View the cervix</p> <p>Use a wooden or plastic spatula to “scrape” cells from the cervix and smear them on a glass slide</p> <p>Slides are read by computer</p> <p>Abnormal cells or groups of cells identified and confirmed by cytopathologist</p>	<p>Meets some of the criteria of a good screening test</p> <ul style="list-style-type: none"> <li>● Noninvasive</li> <li>● Treatment exists</li> <li>● Sensitive/specific</li> </ul> <p>According to manufacturer and other published studies, sensitivity and specificity are acceptable to some clinicians and policymakers</p> <p>Permanent record available in form of slide, computer image</p>	<p>Requires purchase lease or access to very expensive and sophisticated equipment</p> <p>Requires elaborate, complex infrastructure</p> <ul style="list-style-type: none"> <li>● Materials (slides, spatulas)</li> <li>● Reagents (fixatives, stains)</li> <li>● Microscopes</li> <li>● Trained cytotechnicians/cytopathologists</li> <li>● Equipment maintenance</li> <li>● Reliable transport of slides to site where slides are prepared and read</li> </ul> <p>“See and treat” not possible</p>

*Tests for Cervical Cancer Screening*

DEFINITION/ MECHANISM OF ACTION	PROCEDURE	BENEFITS	LIMITATIONS
<p><b>Cervicography™</b></p> <p>Specialized camera used to photograph the cervix. Film developed at lab and photographs interpreted by specially trained personnel.</p> <p>Used primarily as an adjunct to Pap smear, but may be primary screening method</p> <p>Results reported as: Normal</p> <ul style="list-style-type: none"> <li>• LGSIL</li> <li>• HGSIL</li> <li>• Cancer</li> </ul>	<p>Procedure is described to woman</p> <ul style="list-style-type: none"> <li>• Reason</li> <li>• Procedure (what to expect)</li> <li>• Followup</li> </ul> <p>Insert the speculum</p> <p>View the cervix</p> <p>Wash the cervix with a 5% acetic acid solution</p> <p>Photograph the cervix using Cerviscope™, being careful to include a view of the SCJ</p> <p>Send the film to a proprietary laboratory, where it will be developed and interpreted by specially trained staff and both film and results sent back to the site</p>	<p>Meets some of the criteria of a good screening test</p> <ul style="list-style-type: none"> <li>• Practical</li> <li>• Treatment exists</li> <li>• Sensitive/specific</li> </ul> <p>According to manufacturer and other published studies, sensitivity and specificity are acceptable to some clinicians and policymakers</p> <p>Permanent record available in form of photograph</p>	<p>Requires purchase of camera and service from licensed processing facility (cost of camera = \$2,000)</p> <p>Camera may be difficult to maintain/repair</p> <p>Requires infrastructure to send film to development facility and to receive results</p> <p>Delayed reporting of results (see Pap smear)</p> <p>See and treat not possible</p> <p>Two-dimensional representation of a three-dimensional object</p> <p>Photograph may not “sample” entire cervix</p>

DEFINITION/ MECHANISM OF ACTION	PROCEDURE	BENEFITS	LIMITATIONS
<p><b>Colposcopy</b></p> <p>High-powered (15–25x magnification) visual examination of the exocervix, SCJ and endocervical canal</p> <p>Usually accompanied by biopsy of abnormal appearing tissue. Used primarily as a “diagnostic” test. First introduced in 1929.</p> <p>Results usually reported as:</p> <ul style="list-style-type: none"> <li>• <b>Satisfactory</b>—Entire SCJ seen; an abnormal area visualized in its entirety</li> <li>• <b>Unsatisfactory</b>—Entire SCJ not seen; abnormal areas not completely visualized</li> <li>• <b>Normal</b>—Satisfactory colposcopy; no abnormal areas seen</li> <li>• <b>LGSIL</b>—Probable low-grade lesion seen</li> <li>• <b>HGSIL</b>—Probable high-grade lesion seen</li> <li>• <b>Cancer</b>—Probable cancer</li> </ul> <p>Results usually confirmed by biopsy findings</p>	<p>Procedure is described to woman</p> <ul style="list-style-type: none"> <li>• Reason</li> <li>• Procedure (what to expect)</li> <li>• Followup</li> </ul> <p>Insert the speculum</p> <p>View the cervix</p> <p>Usually, take a Pap smear to corroborate results</p> <p>Wash the cervix with a 3–5% acetic acid solution</p> <p>Bring the colposcope into position and inspect the cervix using magnification ranging from 4x to 40x</p> <p>Biopsy abnormal areas</p> <p>Treatment may be provided immediately or when biopsy results are obtained</p>	<p>Widely accepted as definitive “diagnostic” test, especially when accompanied by biopsy</p> <p>Meets some criteria of a good screening test</p> <ul style="list-style-type: none"> <li>• Practical</li> <li>• Treatment exists</li> <li>• Sensitive/specific</li> </ul> <p>Sensitivity/specificity acceptable to most clinicians and policymakers</p> <p>Permanent record possible in form of:</p> <ul style="list-style-type: none"> <li>• photograph</li> <li>• drawn representation of findings</li> </ul> <p>Potential for see and treat</p>	<p>Colposcope is a sophisticated, expensive, easily broken piece of equipment (minimum cost = \$3,000)</p> <p>Requires special training for use</p> <p>Biopsy requires special instruments and infrastructure</p> <p>Biopsy prolongs turn-around time (time from specimen collection to reporting of results)</p>

*Tests for Cervical Cancer Screening*

<b>DEFINITION/ MECHANISM OF ACTION</b>	<b>PROCEDURE</b>	<b>BENEFITS</b>	<b>LIMITATIONS</b>
<p><b>HPV</b></p> <p>Using molecular techniques, the DNA associated with HPV is tested for in a sample of cellular materials taken from the cervix or vagina</p> <p>Could be used on either primary or adjunctive screening test</p> <p>Results reported as:</p> <ul style="list-style-type: none"> <li>● Negative</li> <li>● Positive</li> </ul> <p>In some cases the presence of specific vital subtypes may be noted or specifically tested for</p>	<p>Procedure is described to woman</p> <ul style="list-style-type: none"> <li>● Reason for test</li> <li>● Procedure (what to expect)</li> <li>● Followup</li> </ul> <p>Insert the speculum</p> <p>View the cervix</p> <p>Use a brush or swab to obtain cells from the cervix</p> <p>Once specimen is collected, the brush is placed in a container with a special medium; brush is swished around to create a suspension</p> <p>Specimen container transported to lab where specimen is processed to assess presence of viral DNA; results computed by laboratory</p> <p>Self-obtained specimen also possible by inserting swab deep into vagina then removing and placing into medium, which is then sent for processing</p>	<p>Meets some of the criteria of a good screening test</p> <ul style="list-style-type: none"> <li>● Noninvasive</li> <li>● Treatment exists</li> <li>● Sensitive/specific</li> </ul> <p>According to manufacturer and other published studies, sensitivity and specificity are acceptable to clinicians and policymakers</p> <p>Permanent record available in form of objective assay report</p> <p>Technology may become less expensive in coming years</p> <p>Assay that can provide immediate results could be extremely beneficial</p>	<p>Requires elaborate, complex infrastructure</p> <ul style="list-style-type: none"> <li>● Materials (brushes, jars, tubes, media)</li> <li>● Facility and capability to perform assay (kit required)</li> <li>● Trained lab technologists</li> <li>● Reliable transport of tubes to processing facility</li> <li>● Expensive</li> </ul> <p>If any of these components are missing, potential for system breakdown</p> <p>Tubes easily broken or may leak</p> <p>See and treat not possible</p>

<b>DEFINITION/ MECHANISM OF ACTION</b>	<b>PROCEDURE</b>	<b>BENEFITS</b>	<b>LIMITATIONS</b>
<p><b>Pap Smear</b></p> <p>Cytological examination of a smear of cells taken from the cervix, specifically from the SCJ</p> <p>Slide is examined by cytotechnician/pathologist for cellular changes indicative of inflammation, dysplasia or cancer</p> <p>Results usually reported as:</p> <ul style="list-style-type: none"> <li>• Normal</li> <li>• Inflammation</li> <li>• Atypical Cells of Uncertain Significance (ASCUS)</li> <li>• LGSIL</li> <li>• HGSIL</li> <li>• Cancer</li> </ul>	<p>Procedure is described to woman</p> <ul style="list-style-type: none"> <li>• Reason for test</li> <li>• Procedure (what to expect)</li> <li>• Followup</li> </ul> <p>Insert the speculum</p> <p>View the cervix</p> <p>Use a wooden or plastic spatula to “scrape” cells from the cervix and smear them on a glass slide</p> <p>“Fix” the slides and stain them for microscopic examination</p>	<p>Widely accepted as primary screening method</p> <p>In settings with adequate resources, meets most of the criteria for a good screening test</p> <ul style="list-style-type: none"> <li>• Practical (safe, easy, noninvasive)</li> <li>• Available</li> <li>• Affordable</li> <li>• Treatment exists for disease</li> </ul> <p>Sensitivity and specificity from high quality labs are acceptable to most clinicians and policymakers</p> <p>Permanent record of screening event in the form of a slide</p>	<p>Requires elaborate, complex infrastructure</p> <ul style="list-style-type: none"> <li>• Materials (slides, spatulas)</li> <li>• Reagents (fixatives, stains)</li> <li>• Microscopes</li> <li>• Trained cytotechnicians/cytopathologists</li> <li>• Reliable transport of slides to site where slides are prepared and read</li> </ul> <p>If any of these components are missing, the entire screening program breaks down</p> <p>Small-scale programs will have proportionately greater costs</p> <p>Potential for prolonged turn-around time; this will adversely affect ability to provide followup</p> <p>Slides easily broken either in transport or in storage</p> <p>See and treat not possible</p>

*Tests for Cervical Cancer Screening*

<b>DEFINITION/ MECHANISM OF ACTION</b>	<b>PROCEDURE</b>	<b>BENEFITS</b>	<b>LIMITATIONS</b>
<p><b>VIA</b></p> <p>Visual examination of the exocervix and SCJ using the naked eye (unmagnified) and acetic acid</p> <p>Used solely as a screening test</p> <p>Results reported as:</p> <ul style="list-style-type: none"> <li>• Test-positive</li> <li>• Test-negative</li> <li>• Suspicious for Cancer</li> </ul> <p>(See <b>Chapter 6</b> for details)</p>	<p>Procedure is described to woman</p> <ul style="list-style-type: none"> <li>• Reason</li> <li>• Procedure (what to expect)</li> <li>• Followup</li> </ul> <p>Insert the speculum</p> <p>View the cervix</p> <p>Wash the cervix with a 3–5% acetic acid solution</p> <p>Inspect the cervix including the SCJ with the naked eye</p>	<p>Meets criteria of a good screening test</p> <p>Multiple assessments of sensitivity and specificity indicate it is comparable to Pap smear and HPV or colposcopy</p> <p>Potential for single visit approach</p> <p>Requires no equipment/maintenance other than supply of acetic acid (vinegar), speculum and light source (torch)</p> <p>Can be performed at any level of the healthcare system, by a mid-level provider with proper training</p>	<p>Few published studies documenting the value as a screening test in wide-scale use</p> <p>False positives may overload the referral system</p> <p>Requires competency-based training in order to inspect and make assessment</p>
<p><b>VIAM</b></p> <p>Visual examination of the cervix using acetic acid and low-power magnification</p> <p>May be accompanied by biopsy of abnormal-appearing tissue</p> <p>Results reported as:</p> <ul style="list-style-type: none"> <li>• Normal</li> <li>• Abnormal</li> <li>• Suspicious for Cancer</li> </ul>	<p>Procedure is described to woman</p> <ul style="list-style-type: none"> <li>• Reason</li> <li>• Procedure (what to expect)</li> <li>• Followup</li> </ul> <p>Insert the speculum</p> <p>View the cervix</p> <p>Wash the cervix with a 3–5% acetic acid solution</p> <p>Use a magnifying device like a monacle or optical scope (2–4 power), to look at the cervix</p> <p>Inspect SCJ to identify abnormal areas</p>	<p>Meets criteria of a good screening test</p> <p>Few published studies concerning value of screening test, but available results so far indicate that the test does not appear to offer any advantage over VIA</p> <p>Potential for single visit approach</p>	<p>Dependent on possession of magnifying device</p> <p>Instrument may break, producing “rate-limiting step,” potential for system breakdown</p> <p>Requires moderate training for use</p>

DEFINITION/ MECHANISM OF ACTION	PROCEDURE	BENEFITS	LIMITATIONS
<p><b>Thin-Layer Pap Smear Preparation (ThinPrep™)</b></p> <p>Specimen preparation technique in which cells are collected from cervix, suspended in a special solution, then plated in a single, thin layer on a slide.</p> <p>Cytotechnician/pathologist then examines the slide for cellular changes indicative of inflammation, dysplasia or cancer</p> <p>Used as primary screening method</p> <p>Results usually reported as:</p> <ul style="list-style-type: none"> <li>● Normal</li> <li>● Inflammation</li> <li>● Atypical Cells of Uncertain Significance (ASCUS)</li> <li>● LGSIL</li> <li>● HGSIL</li> <li>● Cancer</li> </ul>	<p>Procedure is described to woman</p> <ul style="list-style-type: none"> <li>● Reason for test</li> <li>● Procedure (what to expect)</li> <li>● Followup</li> </ul> <p>Insert the speculum</p> <p>View the cervix</p> <p>Use a brush to “scrape” cells from the cervix and smear them on a glass slide</p> <p>Once specimen is collected, the brush is placed in a jar/container with a special medium; brush is swished around to create a suspension.</p> <p>Jar/container then sent to lab where specimen is plated onto slides, then stained and read by technician/pathologist</p>	<p>Meets some of the criteria of a good screening test</p> <ul style="list-style-type: none"> <li>● Noninvasive</li> <li>● Treatment exists</li> <li>● Sensitive/specific</li> </ul> <p>According to manufacturer and other published studies, sensitivity and specificity are acceptable to clinicians and policymakers</p> <p>Permanent record available in form of slide</p> <p>Medium (solution in which cells are placed) may also be used to test for HPV</p>	<p>Requires elaborate, complex infrastructure</p> <ul style="list-style-type: none"> <li>● Materials (slides, brushes, jars)</li> <li>● Reagent (transport medium)</li> <li>● Facility where ThinPrep methodology is possible</li> <li>● Microscopes</li> <li>● Trained cytotechnicians/pathologists</li> <li>● Reliable transport of jars to site where slides are prepared and read</li> <li>● Expensive</li> </ul> <p>If any of these components are missing:</p> <ul style="list-style-type: none"> <li>● Small-scale programs will have proportionately greater costs</li> <li>● Potential for system breakdown</li> <li>● Jars easily broken or may leak</li> <li>● See and treat not possible</li> </ul>

*Tests for Cervical Cancer Screening*

<b>DEFINITION/ MECHANISM OF ACTION</b>	<b>PROCEDURE</b>	<b>BENEFITS</b>	<b>LIMITATIONS</b>
<p><b>VILI</b></p> <p>Visual examination of the exocervix and SCJ using the naked eye (unmagnified) and Lugol's Iodine</p> <p>Used solely as a screening test</p> <p>Results reported as:</p> <ul style="list-style-type: none"> <li>• Test-positive</li> <li>• Test-negative</li> <li>• Suspicious for Cancer</li> </ul>	<p>Procedure is described to woman</p> <ul style="list-style-type: none"> <li>• Reason</li> <li>• Procedure (what to expect)</li> <li>• Followup</li> </ul> <p>Insert the speculum</p> <p>View the cervix</p> <p>Wash the cervix with a Lugol's Iodine solution</p> <p>Inspect the cervix including the SCJ with the naked eye</p> <p>Clean the cervix and vagina carefully after the procedure as the iodine solution can stain clothing and linen if it drips out of the vagina</p>	<p>Meets criteria of a good screening test, but Lugol's Iodine less available and more expensive than acetic acid (vinegar)</p> <p>Initial assessments of sensitivity and specificity indicate it is comparable to Pap smear, HPV or colposcopy</p> <p>Potential for single visit approach</p> <p>Requires no equipment/ maintenance other than supply of Lugol's Iodine, speculum and light source (torch)</p> <p>Can be performed at any level of the healthcare system, by a mid-level provider with proper training</p>	<p>Few published studies documenting the value as a screening test in wide-scale use</p> <p>False positives may overload the referral system</p> <p>Requires competency-based training in order to inspect and make assessment</p>

## APPENDIX B

# SCREENING TEST QUALITIES AND THEIR INTERPRETATION<sup>1</sup>

### COMMONLY MEASURED TEST QUALITIES

- **Sensitivity:** Proportion of women testing positive among those who are diseased.
- **Specificity:** Proportion of women testing negative among those who are nondiseased.
- **Positive predictive value (PPV):** Proportion of women having disease among those with a positive test result<sup>2</sup>.
- **Negative predictive value (NPV):** Proportion of women having no disease among those with a negative test result (Last 1983).

**Sensitivity** and **specificity** are qualities that generally measure the intrinsic qualities of diagnostic tests. By definition, if accurately and validly calculated, these measures should not differ substantially across research studies. Because of this, they are good measures for comparing the *relative* value of different tests with regard to identifying true disease or non-disease.

Predictive values, on the other hand, are measures of the clinical utility of the test when applied to a specific population in a particular environment. Predictive values incorporate information on both the intrinsic qualities of the test and the prevalence of disease (i.e., probability of disease prior to testing) in the population being tested (Hulley and Cummings 1988).

**Figure B-1** shows how data are organized to measure the four test qualities described above.

**Figure B-1. Organization of Data to Measure Test Qualities**

		<b>Reference Test</b>		
		+	-	
<b>Clinical Test</b>	+	a	b	a+b
	-	c	d	c+d
		a+c	b+d	
		Sensitivity = $a/a+c$	PPV = $a/a+b$	
		Specificity = $d/b+d$	NPV = $d/c+d$	

<sup>1</sup> Adapted from: Gaffikin L et al (eds). 1998. *Alternatives for Cervical Cancer Screening and Treatment in Low-Resource Settings*. Workshop Proceedings. JHPIEGO: Baltimore, Maryland.

<sup>2</sup> PPV and NPV are affected by the test sensitivity and specificity respectively and the prevalence of disease or nondisease in the population.

## **FACTORS TO CONSIDER WHEN COMPARING THE QUALITY OF RESEARCH TEST RESULTS**

To maximize the usefulness of research findings, research conditions should reflect as closely as possible the field conditions in which the test will ultimately be used. A balance is needed, however, between mirroring field conditions and ensuring the control needed to yield accurate<sup>3</sup> and valid<sup>4</sup> study results. A number of important factors, outlined below, affect the accuracy and validity (internal and external) of research results as well as their comparability across studies (Fahey, Irwig and Macaskill 1995; Jaeschke, Guyatt and Sackett 1994).

### **Defining Disease and Test-Positive**

- Is the terminology used to define disease standard across studies (e.g., CIN versus SIL versus dysplasia)?
- Regardless of the terminology used, are the cutoff points comparable across studies? For example, is cancer included as disease or is the study measuring precancer and cancer separately? This decision should consider the disease cutoff point at which treatment is likely to be most programmatically cost-effective.
- How is the cutoff point defining test-positive best determined with a new test? The definition should maximize sensitivity or specificity (depending on the objectives of testing); for continuous measures, this can best be done using a receiver operating characteristic (ROC)<sup>5</sup>.

### **REFERENCE OR GOLD STANDARD**

- In diagnostic test studies, this is the measure of true disease status against which the performance of the test being evaluated is compared.
- The reference standard for measuring true disease state should be as close to truth as possible. The less accurate the reference standard, the less accurate the observed test qualities of the new test being evaluated.

---

<sup>3</sup> **Accuracy:** degree to which a measurement or estimate represents the true value of the attribute being measured.

<sup>4</sup> **Validity:** degree to which a test measures what it intends to (Weiss 1986).

- **Internal validity:** validity of the inferences/conclusions drawn as they pertain to the actual subjects in the study; that is, study methods used are appropriate for the hypothesis under investigation and the conclusions drawn from study results are valid.

- **External validity:** validity of the inferences/conclusions drawn as they pertain to people outside the study population; that is, the generalizability of the results beyond the study sample (Rothman 1986).

<sup>5</sup> **Receiver operating characteristic (ROC):** A graphic means for assessing the ability of a screening test to discriminate between diseased and nondiseased persons. Sensitivity is graphed as a function of [1-] specificity at several different cutoff points along a curve. The ideal test (100% sensitivity and specificity) would appear as a point along a curve falling at the very upper left hand corner of the graph (Hulley and Cummins 1988).

- An independent assessment of the accuracy of the reference or gold standard should be included as part of quality diagnostic test studies.
- Statistical techniques can also be applied to assess the effect of using a particular reference standard in a diagnostic test study.

## **VERIFICATION OR WORKUP BIAS**

- This occurs when the results of the test being evaluated influence the decision to perform the reference or gold standard test. When this happens, the sampling fraction for subjects undergoing the reference test to verify the presence or absence of disease is much greater for test-positive than test-negative cases.
- Valid test quality measures assume 100% of all subjects have received both the test under evaluation and the reference test. When only a fraction of test-negative cases in fact receive the reference test, statistical extrapolation is possible but this also can yield biased results (especially if the selection of test-negative cases to receive subsequent testing is anything but random).
- Even with random selection of a sample of negatives to receive further testing, if the proportion of test-negatives is less than 50%, bias may still be introduced when statistically adjusting the data.
- Significant bias of this sort usually results in overestimated sensitivity and underestimated specificity rates.

### **Spectrum of Disease/Research Setting**

- This refers to the distribution of disease categories in the research population.
- Sensitivity and specificity may differ across research studies if the spectrum of disease is substantially different. This is because the test may function better at picking up more severe disease or vice versa.
- For this reason, the accuracy of a test, as measured by all of the test qualities mentioned above, is likely to vary according to whether it is being used for screening or followup purposes (and whether followup is immediate as with adjunctive testing or whether followup is part of routine care).
- The best design for establishing the accuracy of a new test is cross-sectional (i.e., across a range of disease) with a population previously unscreened for the disease.
- Test results are most valuable when the test is studied under conditions that most closely resemble clinical practice (i.e., the clinical conditions under which the test is most likely to be applied).

## *Screening Test Qualities and Their Interpretation*

### **Independence of Test Assessments**

- This means that evaluators (particularly of the reference test) should be unaware of the results of previous tests, because these results may influence their assessment of the test being evaluated.

### **Study Sample Size**

- Sample size affects the precision (i.e., width of the confidence interval) of test quality estimates and the statistical power to detect a difference in comparative test studies.
- Quality diagnostic test studies should report not only the calculated point estimates, but also sample sizes involved in each calculation and confidence limits for each estimate.
- Summary measures across studies can best be done using meta-analysis. To qualify for meta-analysis, studies must report the raw data and they should be free from verification bias.<sup>6</sup>

## **REFERENCES**

Fahey MT, L Irwig and P Macaskill. 1995. *American Journal of Epidemiology* 141(7): 680–689.

Hulley SB and SR Cummings (eds). 1988. *Designing Clinical Research*. Lippincott Williams and Wilkins: Baltimore, Maryland.

Jaeschke R, G Guyatt and DL Sackett. 1994. Users' guide to the medical literature. III. How to use an article about a diagnostic test. A. Are the results of the study valid? *Journal of the American Medical Association* 271(5): 389–391.

Last JM (ed). 1983. *A Dictionary of Epidemiology*. Oxford Medical Publications: London.

Rothman KJ. 1986. *Modern Epidemiology*. Little, Brown and Company: Boston, Massachusetts.

Vogt WP. 1983. *Dictionary of Statistics and Methodology*. Sage Publications: London.

Weiss NS. 1986. *Clinical Epidemiology: The Study of the Outcome of Illness*. Oxford University Press: New York.

---

<sup>6</sup> **Meta-analysis:** A quantitative approach whereby data from individual (different) research projects measuring the same thing are used collectively as data points in a statistical analysis of that same measure (Last 1983; Vogt 1983).

## APPENDIX C

# INFECTION PREVENTION PROCESSES<sup>1</sup>

The **three basic steps** for processing instruments, surgical gloves and other reusable items are:

- decontamination,
- cleaning, and either
- sterilization or high-level disinfection (HLD).

Details on how to process instruments, gloves and other items for reuse are provided in this appendix. (See **Appendix F** for the specific steps for sterilizing surgical gloves.)

The sequence for performing each of these processes is summarized in **Table C-1**.

**Table C-1. Infection Prevention Guidelines for Processing Instruments, Surgical Gloves and Other Items**

<b>WASTE DISPOSAL AND DECONTAMINATION</b>	
<b>STEP 1</b>	After completing VIA or cryotherapy of the cervix, and while still wearing gloves, dispose of contaminated objects (swabs and other waste items) in a properly marked leakproof container (with a tight-fitting lid) or plastic bag.
<b>STEP 2</b>	Fully submerge the speculum in a plastic container filled with a 0.5% chlorine solution for 10 minutes before allowing staff and cleaning personnel to handle or clean it. Before submerging assembled needles and syringes, fill with chlorine solution. (This step is necessary to help prevent transmission of HBV and HIV/AIDS to clinic staff.)
<b>STEP 3</b>	All surfaces (such as the procedure table or instrument stand) that could have been contaminated by blood or other body fluids also should be decontaminated by wiping down with chlorine solution.
<b>STEP 4</b>	Immerse both gloved hands in the bucket containing 0.5% chlorine solution and then carefully remove gloves by turning them inside out. If disposing of gloves, place them in the leakproof container or plastic bag. If the gloves will be reused, submerge them in the chlorine solution for 10 minutes for decontamination.

*(table continued on reverse)*

<sup>1</sup> Adapted from: Tietjen L, W Cronin and N McIntosh. 1992. *Infection Prevention for Family Planning Service Programs: A Problem-Solving Manual*. Essential Medical Information Systems, Inc.: Durant, Oklahoma.

**Table C-1. Infection Prevention Guidelines for Processing Instruments, Surgical Gloves and Other Items (continued)**

<b>HIGH-LEVEL DISINFECTION</b>
<p>High-level disinfection by boiling, steaming or using chemicals is acceptable for final processing of instruments and surgical gloves used for VIA or cryotherapy. Surgical (metal) instruments and surgical gloves should be steamed or boiled for 20 minutes and allowed to dry. Instruments can be soaked for 20 minutes in 0.1% chlorine solution prepared with boiled water or 2–4% glutaraldehyde*, thoroughly rinsed in boiled water and air dried.</p> <p>Use immediately or store for up to 1 week in a dry, high-level disinfected container with a tight-fitting lid or cover.</p>
<b>STERILIZATION</b>
<p>Instruments and surgical gloves can be sterilized by autoclaving. If necessary, metal instruments can be sterilized using dry heat.</p> <p><b>Steam sterilization:</b> 121°C (250°F) at 106 kPa (15 lb/in<sup>2</sup>) pressure for 20 minutes for unwrapped items; 30 minutes for wrapped items. Allow all items to dry thoroughly before removing.</p> <p><b>Dry heat:</b></p> <ul style="list-style-type: none"> <li>• 170°C (340°F) for 60 minutes (total cycle time—placing instruments in oven, heating to 170°C, timing for 1 hour and then cooling—is from 2 to 22 hours), or</li> <li>• 160°C (320°F) for 2 hours (total cycle time is from 3 to 32 hours).</li> </ul> <p><b>Note:</b> Dry heat sterilization (170°C for 60 minutes) can be used <b>only</b> for metal instruments.</p> <p><b>Storage:</b> Unwrapped instruments must be used immediately or stored in dry sterile containers (1 week only). Wrapped instruments, such as surgical gloves, can be stored for up to 1 week if the package remains dry and intact and for up to 1 month if sealed in a plastic bag.</p>

\* Glutaraldehyde is a toxic agent. Use in well-ventilated areas and limit exposure time.

## DECONTAMINATION

**Decontamination** makes objects safer to handle by staff **before** cleaning. It is the first step in handling soiled surgical instruments and other items. It is important to decontaminate instruments and items that may have been in contact with blood or body fluids. Immediately after use, place instruments and other items in a 0.5% chlorine solution for 10 minutes. This step rapidly inactivates HBV and HIV and makes items safer to handle.

### Making a Dilute Chlorine Solution

The World Health Organization (WHO) recommends **0.5% chlorine solution** for decontaminating instruments before cleaning or when potable water is not available for making the solution (WHO 1989). For HLD, a 0.1% solution is satisfactory, provided **boiled water** is used for dilution. **Table C-2** describes how to make 0.5% and 0.1% chlorine solutions using commercially available liquid bleach products. The general formula

for making a dilute solution from a commercial preparation of **any** concentration is shown in **Figure C-1**.

**Table C-2. Preparing a Dilute Chlorine Solution from Liquid Bleach (Sodium Hypochlorite Solution) for Decontamination and HLD**

TYPE OR BRAND OF BLEACH (COUNTRY)	CHLORINE % AVAILABLE	PARTS WATER TO 1 PART BLEACH <sup>a</sup>	
		0.5%	0.1% <sup>b</sup>
JIK (Kenya), Robin Bleach (Nepal)	3.5%	6	34
Household bleach (USA, Indonesia), ACE (Turkey), Eau de Javel (France) (15° chlorum <sup>c</sup> )	5%	9	49
Blanquedor, Cloro (Mexico)	6%	11	59
Lavandina (Bolivia)	8%	15	79
Chloros (UK)	10%	19	99
Chloros (UK), Extrait de Javel (France) (48° chlorum <sup>c</sup> )	15%	29	149

<sup>a</sup> Read as one part (e.g., cup or glass) concentrated bleach to x parts water (e.g., JIK [0.5% solution]—mix 1 cup bleach with 6 cups water for a total of 7 cups).

<sup>b</sup> Use **boiled** water when preparing a 0.1% chlorine solution for HLD because tap water contains microscopic organic matter that inactivates chlorine.

<sup>c</sup> In some countries the concentration of sodium hypochlorite is expressed in chlorometric degrees (°chlorum); one °chlorum is approximately equivalent to 0.3% available chlorine.

**Figure C-1. Formula for Making a Dilute Chlorine Solution from Concentrated Solution**

**STEPS**

- Determine concentration (% concentrate) of the chlorine solution you are using.
- Determine total parts water needed (use formula below or **Table C-3**).

$$\text{Total Parts (TP) water} = \left[ \frac{\% \text{ concentrate}}{\% \text{ dilute}} \right] - 1$$

Mix 1 part bleach with the total parts water.

**Example:** Make a dilute solution (0.5%) from 5% concentrated solution.

1. Calculate TP water:  $\left[ \frac{5.0\%}{0.5\%} \right] - 1 = 10 - 1 = 9$
2. Add 1 part concentrated solution to 9 parts water.

The approximate amounts (grams) needed to make 0.5% and 0.1% chlorine-releasing solutions from several commercially available compounds (dry powders) are listed in **Table C-3**. The formula for

making a dilute solution from a powder of **any** percent available chlorine is given in **Figure C-2**.

**Table C-3. Preparing a Dilute Chlorine Solution from Dry Powder**

AVAILABLE CHLORINE REQUIRED	GRAMS PER LITER OF WATER	
	0.5%	0.1% <sup>a</sup>
Calcium hypochlorite (70% available chlorine)	7.1	1.4
Calcium hypochlorite (35% available chlorine)	14.2	2.8
NaDCC (60% available chlorine)	8.3	1.5
Chloramine (25% available chlorine)	20	4
NaDCB-based <b>tablets</b> (1.5 g of available chlorine per tablet)	4 tablets/liter	1 tablets/liter

<sup>a</sup> Use **boiled** water when preparing a 0.1% chlorine solution for HLD because tap water contains microscopic organic matter which inactivates chlorine.

*Adapted from:* World Health Organization 1989.

**Figure C-2. Formula for Making a Dilute Chlorine Solution from Dry Powder**

**STEPS**

- Determine concentration (% concentrate) of the powder you are using.
- Determine grams bleach needed (use formula below or **Table C-4**).

$$\text{grams/liter} = \left[ \frac{\% \text{ Dilute}}{\% \text{ Concentrate}} \right] \times 1000$$

- Mix measured amount of bleach powder with 1 liter of water.

**Example:** Make a dilute chlorine solution (0.5%) from a dry powder (35%).

Calculate grams/liter:  $\left[ \frac{0.5\%}{35\%} \right] \times 1000 = 14.2 \text{ g/L}$

Add 14.2 grams (~14 g) to 1 liter of water.

If items cannot be cleaned immediately after decontamination, rinse them with cool water to prevent discoloration and corrosion (rusting) and to remove visible organic material. Personnel should wear gloves while handling soiled instruments, even after decontamination. Inexpensive utility gloves work well for this.

Surfaces (especially procedure tables) that may have come in contact with body fluids should also be decontaminated. Wiping large surfaces

with a suitable disinfectant such as a 0.5% chlorine solution before reuse, when visibly contaminated or at least daily, is an easy, inexpensive way to decontaminate them.

## **CLEANING**

Cleaning is a crucial step in providing safe, infection-free equipment and instruments. A thorough cleaning with water and liquid soap or detergent physically removes organic material such as blood and body fluids. Dried organic material can trap microorganisms in a residue that protects them against sterilization or HLD. Organic matter also can partially inactivate disinfectants, rendering them less effective (Porter 1987).

Utility gloves should be worn while cleaning instruments and equipment. Discard gloves if torn or damaged; otherwise, clean and leave to dry at the end of the day for use the following day. In addition to wearing gloves, extreme care must be taken to prevent needlesticks or cuts.

Staff should wear protective glasses, plastic visors or goggles, if available, while cleaning instruments and other items. This protects staff from splashing contaminated water into their eyes.

Clean instruments with a brush (old toothbrushes work well) and soapy water. Give special attention to instruments with teeth, joints or screws where organic material can collect. After cleaning, rinse items thoroughly with water to remove detergent residue, which can interfere with chemical disinfection.

## **HIGH-LEVEL DISINFECTION**

When sterilization is not possible or not suitable, HLD is the **only** acceptable alternative for the final step in processing instruments. High-level disinfection destroys all microorganisms, including viruses causing hepatitis B and AIDS, but **does not reliably kill all bacterial endospores**. High-level disinfection can be achieved by boiling in water, steaming or soaking in chemical disinfectants such as 0.1% chlorine or 2–4% glutaraldehyde. Because boiling and steaming require only inexpensive equipment, which usually is readily available, they are the preferred methods for small clinics or those located in remote areas. Regardless of the method selected, however, HLD is effective **only** when instruments and other items first thoroughly cleaned and rinsed **before** HLD.

**Moist heat at 80°C kills essentially all bacteria, viruses, parasites and fungi in 20 minutes.** Unless the altitude of the health facility is over 5,500 meters (18,000 feet) it is **not** necessary to increase the steaming or boiling time (Favero 1985).

**High-Level  
Disinfection by  
Boiling**

Open or take apart all instruments and other items. Submerge them in water and cover pan. Boil for 20 minutes. Timing should begin when the water is at a rolling (bubbling) boil and all items should be totally under the water. Nothing should be added to the container after the water begins to boil. After boiling for 20 minutes, remove boiled items using high-level disinfected forceps, place in a high-level disinfected container and allow to cool and air dry.

Use instruments and other items immediately or leave in a covered, **dry**, high-level disinfected container. (The container used for drying the instruments can be used for storage only if there is no water in the bottom of the container.) Store for up to 1 week.

**Boiling Tips**

- Always steam or boil for 20 minutes using a pot with a lid.
- Start timing when the water begins to boil.
- Items should be covered completely<sup>a</sup> with water.
- Do not add anything to the pot after the water begins to boil.

<sup>a</sup> An IPAS report documented that the interior temperature of a plastic cannula floating on the surface of boiling water reaches a temperature of 96–98 °C in less than a minute (IPAS 1993). For items that float (e.g., plastic syringes, surgical gloves or rubber items), it is not absolutely necessary that they be fully covered by the water to achieve HLD.

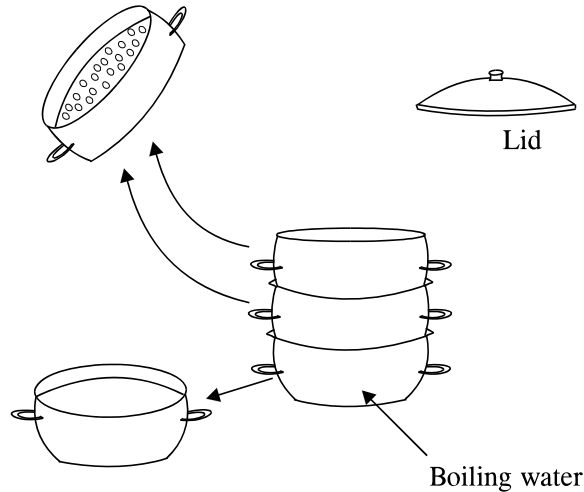
**High-Level  
Disinfection by  
Steaming**

Steaming surgical gloves has been used as the final step in processing gloves for many years in Indonesia and other parts of South East Asia. In 1994 a study by McIntosh et al confirmed the effectiveness of this process.

In this study, the steamer used (**Figure C-3**) consisted of:

- a bottom pan (approximately 31 cm in diameter) for boiling water;
- one, two or three circular pans with multiple, 0.5 cm (diameter) holes in their bottoms to permit the passage of steam up through them and water back down to the bottom pan; and
- a lid that fits on the top pan.

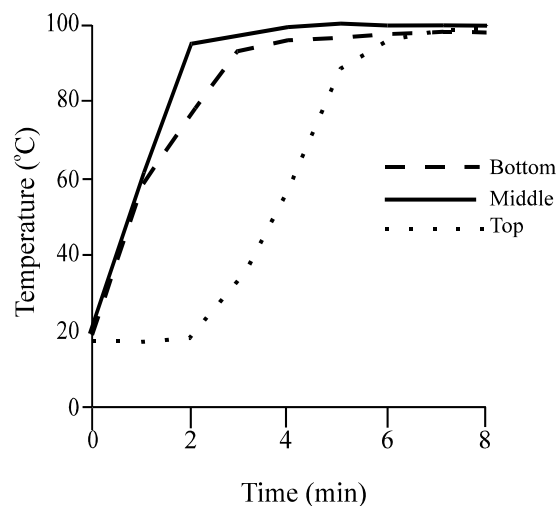
Figure C-3. Steamer Used for HLD



Two types of tests were conducted to determine whether surgical gloves could be high-level disinfected using this process.

**In the first set of experiments**, a thermocouple was placed inside a glove in each of the three pans and the rate and extent of the temperature change recorded. As shown in **Figure C-4**, when from 5 to 15 pairs of surgical gloves were placed in each of the three pans, the temperature reached 96–98 °C in less than 4 minutes in the bottom and middle pans and within 6 minutes in the upper pan. Thereafter the temperature remained constant throughout the remaining 20 minutes.

Figure C-4. Temperature Rise in Gloves as a Function of Tray Position



In the second set of experiments, batches of new surgical gloves were contaminated with *Staphylococcus epidermidis*, *Staphylococcus aureus*, *Pseudomonas aeruginosa* and *Candida albicans* as well as *Bacillus subtilis* (heat-sensitive) and *Bacillus stearothermophilus* (heat-resistant) endospores. Next the gloves were placed in one of the three pans and

steamed for 20 minutes. After this, they were removed from the pans and incubated for 24 hours in sterile media and then plated on blood agar. In all cases (6, 15 and 30 gloves per pan), there was no growth of any microorganisms or *B. subtilis* endospores at 24 hours and, as expected, only a reduction in the number of *B. stearothermophilus* endospores.

Based on the results of these experiments, it would appear that steaming is effective in high-level disinfecting surgical gloves.

**Use of Steaming for  
HLD: Advantages  
and Disadvantages**

**Steaming has several distinct advantages over boiling** for the final processing of surgical gloves. Although boiling and steaming gloves are equally easy to do, drying boiled gloves is not practical because it is difficult to prevent contamination while they are air-drying. After steaming, the gloves do not need to be handled and can be stored in the steamer pan, so there is less chance of contaminating them. An additional advantage is that steaming is more cost-effective because it uses much less fuel than does boiling.

The **major disadvantage of steaming** is that if the steamers available locally are small, it is only practical to use them for small items (e.g., surgical gloves and syringes). Large boiling pots are easier to use with metal instruments and require less attention to be sure that the boiling process is being done correctly.

**High-Level  
Disinfection by  
Soaking in a  
Chemical Solution**

At present, only four chemicals are approved worldwide for use as high-level disinfectants:

- chlorine,
- glutaraldehyde,
- formaldehyde (formalin), and
- hydrogen peroxide.

Formaldehyde is very irritating to the skin and, eyes and respiratory tract, and is suspected to be a human carcinogen; hydrogen peroxide is highly corrosive and is unstable in the presence of heat and light. Thus, in the context of this manual, chlorine solutions and glutaraldehydes are the preferred chemicals for use in high-level disinfection. Although **alcohols** and **iodophors** are inexpensive and readily available, they are no longer classified as high-level disinfectants (Rutala 1997). Alcohols do not kill some viruses, and *Pseudomonas* species have been known to multiply in iodophors. These chemicals should be used for disinfection **only** when the high-level disinfectants listed above are not available or appropriate.

**Table C-4** provides guidelines for preparing and using these chemical disinfectants.

**Table C-4. Preparing and Using Chemical Disinfectants**

PREPARING AND USING CHEMICAL DISINFECTANTS										
Chemicals for Sterilization or High-Level Disinfection										
Disinfectant (common solution or brand)	Effective Concentration	How to Dilute	Skin Irritant	Eye Irritant	Respiratory Irritant	Corrosive	Leaves Residue	Time Needed for HLD	Time Needed for Sterilization	Activated Shelf Life <sup>a,b</sup>
<b>Chlorine</b> (3–15%)	0.1%	Dilution procedures vary <sup>c</sup>	Yes (with prolonged contact)	Yes	Yes	Yes <sup>d</sup>	Yes	20 minutes	Do not use	Change daily; sooner if cloudy
<b>Glutaraldehyde</b> (Cidex)	Varies (2–4%)	Varies: read instructions on container	Yes	Yes vapors	Yes	No	Yes	20 minutes at 25°C <sup>e</sup>	10 hours for Cidex	Change every 14 days; sooner if cloudy
Chemicals for Disinfection (alcohols and iodophors are not high-level disinfectants)										
<b>Alcohol</b> (ethyl or isopropyl)	60–90%	Use full strength	Yes (can dry skin)	Yes	No	No	No	Do not use	Do not use	Change weekly; daily if heavily used; sooner if cloudy
<b>Iodophors</b> (10% povidone iodine/PVI)	Approximately 2.5%	1 part 10% PVI to 3 parts water	No	Yes	No	Yes	Yes	Do not use	Do not use	Change daily

<sup>a</sup> All chemical disinfectants are heat and light sensitive and must be stored appropriately.

<sup>b</sup> Always check manufacturer’s instructions for when to discard.

<sup>c</sup> See **Tables C-3** and **C-4** for instructions on preparing chlorine solutions.

<sup>d</sup> Corrosive with prolonged (> 20 minutes) contact and/or concentrations ≥ 0.5% if not immediately rinsed with boiled water.

<sup>e</sup> Different commercial preparations of Cidex and other glutaraldehydes are effective at lower temperatures (20 °C) and for a longer activated shelf life.

*Adapted from: Rutala 1997.*

The major **advantages** and **disadvantages** of each disinfectant are described below.

- **Chlorine solutions** (0.1%) are fast acting, very effective against HBV and HIV, inexpensive and readily available.

A major disadvantage is that concentrated chlorine solutions ( $\geq 0.5\%$ ) can discolor metals and cause rust. Stainless steel instruments, however, can be soaked safely in a 0.1% chlorine solution (using a plastic container) for up to 20 minutes. Discoloration is only a problem where calcium (not sodium) hypochlorite powders are used. (Wiping instruments with vinegar, which is weakly acidic, will quickly remove the discoloration.) Also, rust will **not** be as much of a problem if items are rinsed with boiled water and dried **promptly**.

---

**Remember:**

Glutaraldehyde solutions leave a residue; therefore, instruments must be rinsed thoroughly with boiled water after HLD to remove any residue and prevent skin irritation.

---

Because chlorine solutions lose their effectiveness with time, fresh solutions should be made at least daily or more often if the solution is visibly cloudy.

- **Glutaraldehydes** (2–4%), which can be used for chemical sterilization, are effective high-level disinfectants as well. Although less irritating than formaldehyde, staff should wear gloves, protect eyes from splashes, limit exposure time and use only in well-ventilated areas.

**Key Steps in Chemical High-Level Disinfection**

- Decontaminate instruments that have been in contact with blood or body fluids.
- Thoroughly clean and dry all instruments.
- Cover all items completely with correct dilution of high-level disinfectant that has been properly stored.
- Soak for 20 minutes.
- Remove using high-level disinfected forceps or gloves.
- Rinse well with boiled water and air dry.
- Use promptly or store for up to 1 week in a high-level disinfected, covered container.

To prepare a high-level disinfected container, boil if small or (if large) fill a plastic container with 0.5% chlorine solution and soak for 20 minutes. (The chlorine solution can be transferred to a plastic container and reused.) Rinse the inside thoroughly with boiled water. Air dry before use.

**Storage of Disinfectants**

- Disinfectants should be stored in a cool, dark area.
- Never store chemicals in direct sunlight or in excessive heat (e.g., upper shelves in a tin-roofed building).

**Processing Used Chemical Containers**

**Glass containers** may be washed with soap and water, rinsed, dried and reused. Alternatively, thoroughly rinse the container (at least two times) with water and dispose of by burying.

**Plastic containers** used for toxic substances such as glutaraldehyde should be rinsed (at least two times) with water and disposed of by burning or burying.<sup>2</sup>

**Note:** Do not reuse plastic containers that originally held glutaraldehydes.

**Products That Should Not Be Used as Disinfectants**

Many antiseptic solutions are used incorrectly as disinfectants. Although antiseptics (sometimes called “skin disinfectants”) are adequate for cleaning skin before an injection or surgical procedure, they are not appropriate for disinfecting surgical instruments. **They do not destroy bacteria, viruses or endospores reliably.** For example, Savlon (chlorhexidine gluconate with or without cetrimide), which is readily available worldwide, is a good antiseptic but is often mistakenly used as a disinfectant.

Antiseptics that should not be used as disinfectants are:

- Acridine derivatives (e.g., gentian or crystal violet)
- Cetrimide (e.g., Cetavlon<sup>®</sup>)
- Chlorhexidine gluconate (e.g., Hibiscrub, Hibitane)
- Chlorhexidine gluconate and cetrimide in various concentrations (e.g., Savlon)
- Chlorinated lime and boric acid (e.g., Eusol<sup>®</sup>)
- Chloroxylenol (e.g., Dettol)
- Hexachlorophene (e.g., pHisoHex<sup>®</sup>)
- Mercury solutions (such as mercury laurel) cause birth defects and are too toxic to use as either disinfectants or antiseptics (Block 2000).

Other products frequently used to disinfect equipment are 1–2% phenol (e.g., Phenol<sup>®</sup>), 5% carbolic acid (e.g., Lysol<sup>®</sup>) and benzalkonium chloride, a quaternary ammonium compound (e.g., Zephiran<sup>®</sup>). These are low-level disinfectants and should be used only to decontaminate

---

<sup>2</sup> To further prevent plastic containers from being reused, put a hole in each container before disposal so that it cannot be used to carry water or other liquids.

environmental surfaces (e.g., examining tables) when chlorine compounds are not available.

## STERILIZATION

Instruments and other items, such as needles or scalpels, that come into direct contact with tissues beneath the skin should be sterilized after first being decontaminated and thoroughly cleaned, rinsed and dried. **The sterilization process destroys all microorganisms, including bacterial endospores.** Bacterial endospores are particularly difficult to kill because of their tough coating. (Bacteria that form endospores include *clostridia tetani*, which causes tetanus.) Sterilization can be achieved by autoclave (high-pressure steam), dry heat or chemicals (“cold sterilization”).

### Heat Sterilization

---

**Remember:** When instruments and equipment are steam sterilized, it is essential that steam reach all surfaces; **autoclaving closed containers will sterilize only the outside of the containers!**

---

High-pressure saturated steam (autoclaving) or dry heat (by hot air oven) are the most readily available methods used for sterilization. Steam sterilization generally is the method of choice for instruments and other items used in family planning and healthcare facilities. Where electricity is unavailable or unreliable, instruments can be sterilized in a nonelectric autoclave using kerosene as a heat source.

**Dry-heat sterilizers** are appropriate for humid climates but need a constant supply of electricity, making them impractical in many remote (rural) areas. Furthermore, dry-heat sterilization can be used only with glass or metal objects—other substances, such as plastic and rubber, can melt and could burn. (Needles and other instruments with cutting edges should be dry-heat sterilized at temperatures not higher than 160 °C/320 °F; otherwise, the sharpness of the cutting edges will become dull.) The standard conditions for sterilization by steam or dry heat are shown in the following box.

#### Standard Conditions for Heat Sterilization

**Steam sterilization:** Temperature should be 121°C (250°F); pressure should be 106 kPa (15 lb/in<sup>2</sup>); 20 minutes for unwrapped items; 30 minutes for wrapped items. Allow all items to dry before removing.

**Note:** Pressure settings (kPa or lbs/in<sup>2</sup>) may vary slightly depending on sterilizer used. Whenever possible, follow manufacturer’s recommendations.

**Dry heat:** 170°C (340°F) for 1 hour (total cycle time—placing instruments in oven, heating to 170°C, timing for 1 hour and then cooling—is from 2 to 22 hours) or 160°C (320°F) for 2 hours (total cycle time is from 3 to 32 hours).

Sterile instruments should be used immediately unless they:

- have been wrapped in a double layer of muslin, paper or other appropriate material prior to steam sterilization; or
- can be stored in a dry sterile container with a tight-fitting lid.

The material used for wrapping instruments must be porous enough to let steam through but tightly woven enough to protect against dust particles and microorganisms.

Wrapped sterile instruments have a shelf life of up to 1 week, **but only if the packaging is kept dry and intact** (Perkins 1983). Placing a wrapped pack in a sealed plastic bag will increase its shelf life to 1 month. All packs and sterile containers should be labeled with an expiration date.

### **Chemical Sterilization**

An alternative to steam or dry-heat sterilization is chemical sterilization by soaking for 8 to 10 hours in a 2–4% glutaraldehyde. Glutaraldehydes, such as Cidex®, often are in short supply and expensive, but they are the only practical liquid sterilants usable for instruments such as laparoscopes that cannot be heated. Because glutaraldehydes require special handling and leave a residue on treated instruments, rinsing with **sterile** water (which can be prepared only by autoclaving) is preferable. (Because boiling does not inactivate some endospores reliably, using boiled water can contaminate sterile instruments.)

When using glutaraldehyde, wear gloves, protect eyes from splashes, limit exposure time, and use only in a well-ventilated area.

## **REFERENCES**

Block SS. 2000. *Disinfection, Sterilization and Preservation*, Fifth edition. Lippincott Williams & Wilkins: Baltimore, Maryland.

Department of Health and Human Services (DHHS). 2000. *Ninth Report on Carcinogens*. DHHS: Washington, DC.

Favero M. 1985. Sterilization, disinfection and antisepsis in the hospital, in *Manual of Clinical Microbiology*, Fourth edition. Lennette EH et al (eds). American Society for Clinical Microbiology: Washington, DC.

IPAS. 1993. *Boiling IPAS Cannulae to Achieve High Level Disinfection*. IPAS: Carrboro, North Carolina.

McIntosh N et al. 1994. *Practical methods for high level disinfection of surgical gloves*. Paper presented at American Public Health Association Annual Meeting. Washington DC, 31 October–4 November.

Perkins JJ. 1983. *Principles and Methods of Sterilization in Health Sciences*, Second edition, 338–402. Charles C. Thomas: Springfield, Illinois.

Porter CW. 1987. Prevention of infection in voluntary surgical contraception. *Biomedical Bulletin* 6(1): 1–7.

Rutala WA. 1997. Disinfection, sterilization and waste disposal, in *Prevention and Control of Nosocomial Infections*, Third edition. Wenzel RP (ed). Lippincott Williams & Wilkins: Baltimore, Maryland.

Salle AJ. 1973. *Fundamental Principles of Bacteriology*, Seventh edition. McGraw-Hill Book Company: New York.

Spaulding EH. 1939. Studies on the chemical sterilization of surgical instruments. *Surgery, Gynecology and Obstetrics* 69(6): 738–744.

Tietjen L, W Cronin and N McIntosh. 1992. *Infection Prevention for Family Planning Service Programs: A Problem-Solving Reference Manual*. Essential Medical Information Systems, Inc.: Durant, Oklahoma.

World Health Organization (WHO). 1989. *AIDS Series 2: Guidelines on Sterilization and High-Level Disinfection Methods Effective Against Human Immunodeficiency Virus (HIV)*. WHO: Geneva.

## APPENDIX D

# TECHNICAL OVERVIEW OF THE CRYOTHERAPY SYSTEM<sup>1</sup>

This section provides general information on the Model LL100 cryotherapy system<sup>2</sup> (Wallach Surgical Devices, Inc.) to familiarize the user with the major components of the system, as well as the technical aspects of its use. It also provides information on post-procedure processing, for infection prevention, and on proper storage. **Appendix E** provides guidance for troubleshooting problems commonly encountered when using the LL100 Cryotherapy System. Page references to such guidance appear where appropriate throughout this section.

## ANATOMY OF THE SYSTEM

The cryotherapy system (**Figure D-1**), which is designed to connect to a gas cylinder (**Figure D-2**), consists of the following components:

- Metal cryotip with plastic sleeve;
- Hand-held cryotherapy unit (or “cryogun” or “cryoprobe”), which includes the handle, freeze and defrost triggers, and insulated probe;
- Flexible hose connecting the regulator to the cryotherapy unit; and
- Regulator with pressure gauge, cryotherapy unit holder, safety valve, and exhaust port.

---

<sup>1</sup> Adapted from: Blumenthal P. 2004. *The Model III0 Cryotherapy System: An Operational and Use Guide to Basic Repair and Maintenance*. JHPIEGO: Baltimore.

<sup>2</sup> In this manual, illustrations and instructions specifically related to the cryotherapy system/unit are based on the Wallach LL100 Cryotherapy System (Wallach Surgical Devices, Inc., 235 Edison Road, Orange, CT 06477, USA. [www.wallachsd.com](http://www.wallachsd.com)). While the principles of cryotherapy are the same regardless of the system used, other systems may differ in appearance, operating features, and procedures for proper use.

Figure D-1. Cryotherapy System<sup>3</sup>

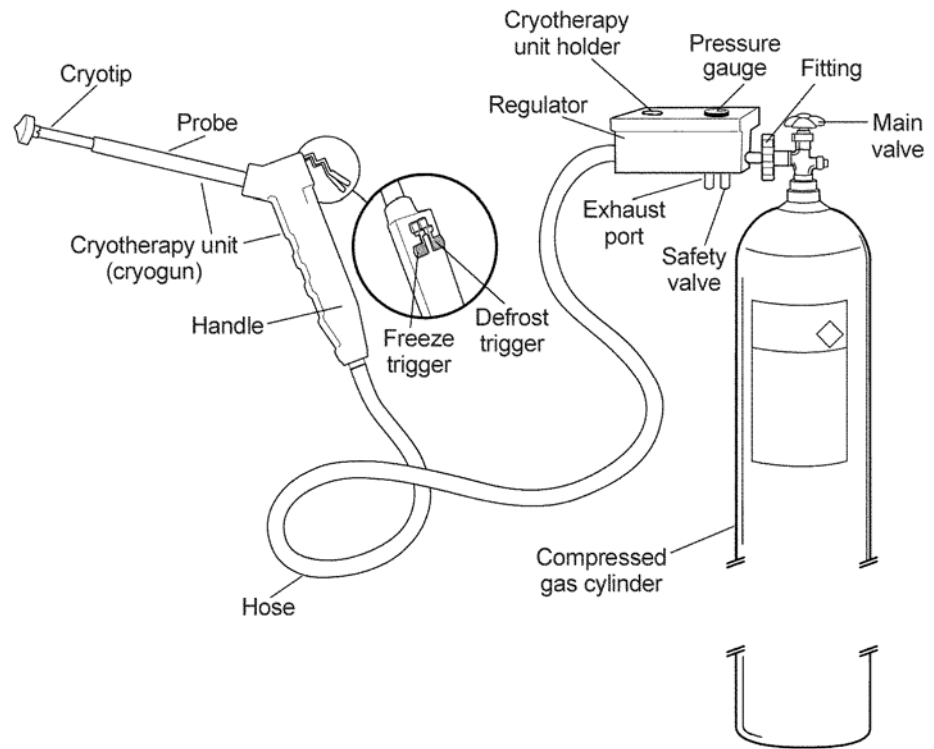


Figure D-2. Choosing an Appropriate Gas Cylinder

Gas cylinders can be obtained from a local vendor. Here are some tips for choosing an appropriate gas cylinder for use with the cryotherapy system:

- The gas cylinder may contain either compressed carbon dioxide (CO<sub>2</sub>) or nitrous oxide (N<sub>2</sub>O) gas as the coolant; whether to use CO<sub>2</sub> or N<sub>2</sub>O gas depends on local cost and availability of the gases. Whenever feasible, “medical grade” gas should be used; if not available or affordable, “food/service” grade (CO<sub>2</sub>) or industrial grade gas may be substituted. **Gases other than CO<sub>2</sub> and N<sub>2</sub>O should never be mixed in or used with the cryotherapy system.**
- Gas cylinders can be purchased in several different sizes:
  - Cylinders measuring about 1.2 to 1.5 meters tall are best for clinic use.
  - Smaller gas cylinders may contain only enough gas for a few procedures and are appropriate for occasional, mobile use only.
- Only “non-siphon” gas cylinders should be used (i.e., cylinders without a tube that extends inside from the cylinder valve at the top to the bottom of the cylinder). Siphon cylinders should never be used.

**Note:** For complete information on handling compressed gas cylinders, refer to C.G.A. Pamphlet P-2, available from Compressed Gas Association, 1725 Jefferson Davis Highway, Suite 1004, Arlington, VA 22202, USA.

<sup>3</sup> There are two types of fittings used to connect the regulator to the gas cylinder. In this picture, the United States (US) fitting is shown. A British fitting may also be used. For more information about the US and British fittings, see **Figure D-3**.

## PREPARING FOR USE

Before cryosurgical treatment procedures are performed each day, the cryotherapy system must be prepared for use—according to the following guidelines—to help ensure safe, proper functioning.

**Note:** Before preparing the system for use, it is important to ensure that it was appropriately processed after last use for infection prevention. For more information, see Post-Procedure Processing (page D-6).

### Checking the Gas Cylinder

- Ensure that the gas cylinder is not warm/hot to the touch before attaching it to the system. Do not use (or store) the cylinder near heat sources (e.g., radiators, furnaces). Heat increases the pressure of the gas in the cylinder. This pressure can, in turn, damage the cryotherapy unit or break the rupture disk in the safety valve, causing the system to stop working.
  - ⇒ If the cylinder is warm/hot to the touch, move it to a cool place and let it stand overnight, if possible.
  - ⇒ If the cylinder is still warm to the touch, wrap it in wet cloths until cool.

### Connecting the Regulator to the Gas Cylinder

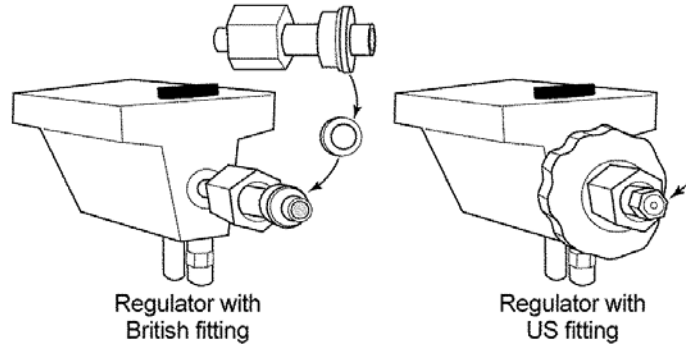
- Connect the regulator to the gas cylinder.
- Tighten the US fitting by hand only. If you are using a British fitting, which requires a wrench, tighten only until secure. **Be careful not to over-tighten.** (For more information about tightening the regulator fittings, see **Figure D-3.**)

#### Figure D-3. Additional Instructions for Tightening Regulator Fittings

There are two different types of fittings (**Figure D-4**) for connecting the regulator to the gas cylinder:

- The **British fitting** (left) requires a separate washer. Before connecting the regulator to the cylinder via the British fitting, place the washer over the brass nipple that extends from the fitting.
  - Slide the brass connecting-nut over the nipple and hand-tighten to the cylinder connector.
  - Using a spanner wrench, tighten the brass nut only until secure. Be careful not to over-tighten.
- The **US fitting** (right) does not need a separate washer, as a white plastic insert is permanently installed in the end of the nipple.
  - Slide the black hand-wheel with the brass nut over the nipple end and connect to the cylinder connector.
  - Tighten by hand only. Be careful not to over-tighten.

Figure D-4. British and US Regulator Fittings



### Checking the Gas Pressure<sup>4</sup>

- When the regulator is connected to the gas cylinder, open the main valve at the top of the cylinder by turning counterclockwise.
  - ⇒ If gas is leaking at point where the regulator attaches to the gas cylinder, see Problem 1 (**Appendix E**, page E-1).
  - ⇒ If gas is leaking from the handle, see Problem 2 (**Appendix E**, page E-1).
  - ⇒ If gas is leaking from the hose, see Problem 3 (**Appendix E**, page E-1).
  - ⇒ If gas is leaking from the regulator, see Problem 4 (**Appendix E**, page E-1).
- Check the gas pressure on the regulator to ensure that the pressure gauge needle is within the green-shaded area, which represents the safe operating range (40–70 kg/cm<sup>2</sup> for CO<sub>2</sub> and 40–50 kg/cm<sup>2</sup> for N<sub>2</sub>O).
  - ⇒ If the pressure gauge needle is in the red-shaded area, see Problem 5 (**Appendix E**, page E-2).
  - ⇒ If the pressure gauge needle is in the yellow-shaded area, see Problem 6 (**Appendix E**, page E-2).
  - ⇒ If there is a loud noise and gas escapes from the safety valve, see Problem 7 (**Appendix E**, page E-2).

### Installing the Cryotip<sup>4</sup>

**Note:** Before installing the cryotip, it is important to ensure that it was appropriately processed after last use for infection prevention. For more information, see Post-Procedure Processing (page D-6).

- Remove the protector tube to uncover the thin metal tube on the end of the probe (**Figure D-5**).
- Screw the cryotip onto the end of the probe by turning it clockwise (**Figure D-6**). Tighten by hand only. Be careful not to over-tighten.

<sup>4</sup> This step should be performed at the beginning of the day and before each cryosurgical procedure.

Figure D-5. Removing Protector Tube from Probe

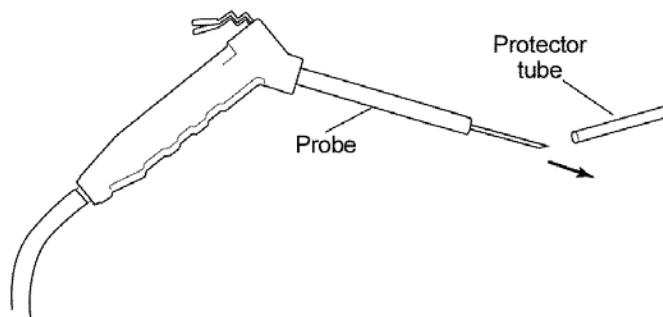
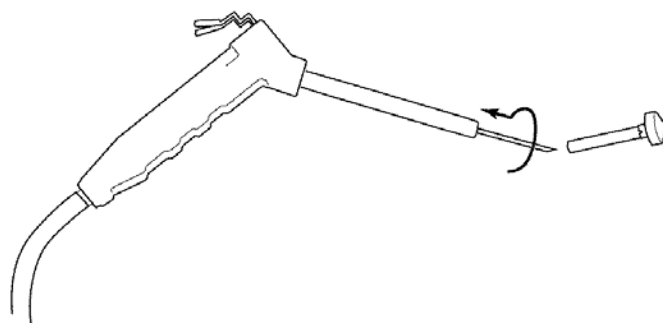


Figure D-6. Installing Cryotip



### Checking that System Is Working Properly<sup>5</sup>

- Press the freeze (left) trigger. After several seconds, the cryotip should frost.
  - ⇒ If no gas flows when the freeze trigger is depressed, see Problem 8 (**Appendix E**, page E-3).
- Release the freeze (left) trigger and press the defrost (right) trigger. After several seconds, the frost should disappear.
  - ⇒ If no gas flows when the defrost trigger is depressed, see Problem 9 (**Appendix E**, page E-3).
  - ⇒ If the triggers will not move, see Problem 10 (**Appendix E**, page E-3).

## THE FREEZE-CLEAR-FREEZE TECHNIQUE

When using CO<sub>2</sub> cylinders, the cryotherapy unit may become blocked with small ice particles, cutting off the gas flow in the system and causing it to stop working. To prevent this from happening, it is important to use the freeze-clear-freeze (FCF) technique—according to the guidelines shown in **Figure D-7**—throughout the entire freezing period in all cryosurgical treatment procedures. Application of the FCF technique prevents the cryotherapy unit from becoming blocked with ice

<sup>5</sup> This step should be performed at the beginning of the day and before each cryosurgical procedure.

and supports proper functioning of the entire system. FCF will not interfere with the proper freezing of cervical tissue.

- ⇒ If, while performing a cryosurgical procedure using CO<sub>2</sub>, gas flow sputters/stops and the cryotherapy unit stops working, see Problem 11 (**Appendix E**, page E-3).

**Figure D-7. Applying Freeze-Clear-Freeze Technique**

To apply the FCF technique:

- Use an electronic timer, a stopwatch, or a clock with a sweeping second hand to monitor the elapsed time, or have an assistant watch a clock and announce the timing at regular intervals.
- The FCF technique should be applied from the start of the cryosurgical treatment procedure.
  - Begin applying cryotherapy by pressing the FREEZE (left) trigger.
  - After the first 15 seconds, (1) briefly press the DEFROST (right) trigger **for only a second or less and then release it** and then (2) immediately press the FREEZE (left) trigger again to continue freezing.
- Repeat this technique every 15 seconds during the entire 3 minutes of freezing. If possible, have an assistant monitor the timing and announce “Clear!” every 15 seconds to signal the provider to use FCF.
  - ⇒ If the cryotherapy unit does become blocked and gas flow stops, follow the steps noted in Problems 8 or 9 (**Appendix E**, page E-3) to melt the ice.

**Note:** While using the FCF technique during a cryosurgical treatment procedure, white puffs of frost or small pieces of ice will blow out of the exhaust port on the bottom of the regulator. This indicates that the unit is clearing itself and preventing ice buildup.

**POST-PROCEDURE PROCESSING**

After completing a cryosurgical treatment procedure, the provider and/or other health care worker, as appropriate, should perform the following steps to help ensure prevention of infection:

- Put new examination or utility gloves on both hands.
- Wipe the regulator, hose, and cryotherapy unit (the probe last) with a cloth dampened with soapy water.
- Unscrew the cryotip from the probe (**Figure D-8**), and place the protector tube over the thin metal tube at the end of the probe (**Figure D-9**).
- Put the cryotherapy unit in the holder on the regulator.
- Separate the cryotip from the plastic sleeve, and insert the rubber stopper into the bottom of the cryotip shaft (**Figure D-10**).

Figure D-8. Removing Cryotip

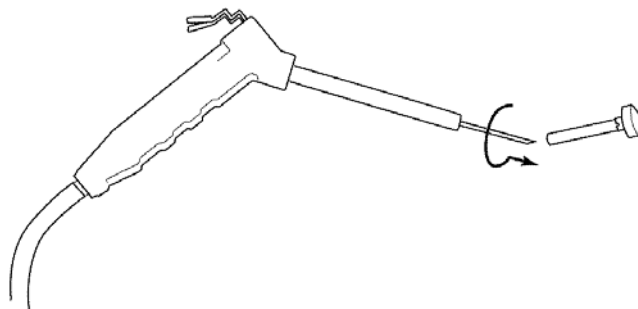


Figure D-9. Placing Protector Tube on Probe

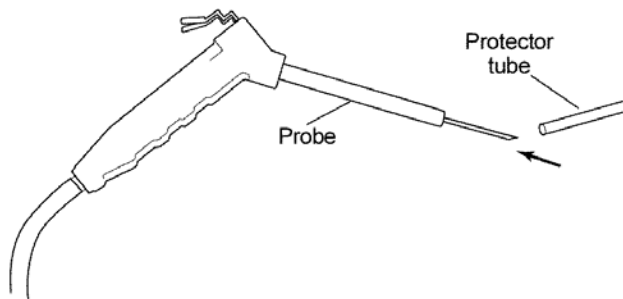
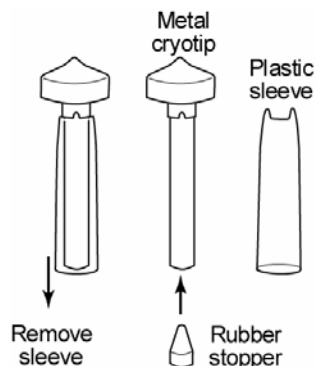


Figure D-10. Removing Plastic Sleeve and Inserting Rubber Stopper



- Wash the cryotip and plastic sleeve with soapy water until visibly clean. Ensure that the rubber stopper does not fall out during washing.
- Rinse the cryotip and plastic sleeve thoroughly with water. Allow them to air-dry.
- After cleaning and drying the cryotip and plastic sleeve, they should be:
  - high-level disinfected by boiling or steaming, or by soaking in high-level disinfectant chemicals (e.g., 1% chlorine [made with boiled water] or 2–4% glutaraldehyde); or
  - sterilized with steam (autoclave), dry heat (dry heat oven), or gas (gas sterilizer).

**Note:** The cryotip can be sterilized using an autoclave, but the plastic sleeve cannot. **Never put the plastic sleeve in an autoclave.**

**Note:** If desired, the cryotip can be reattached to the probe and both can be high-level disinfected using chemicals.

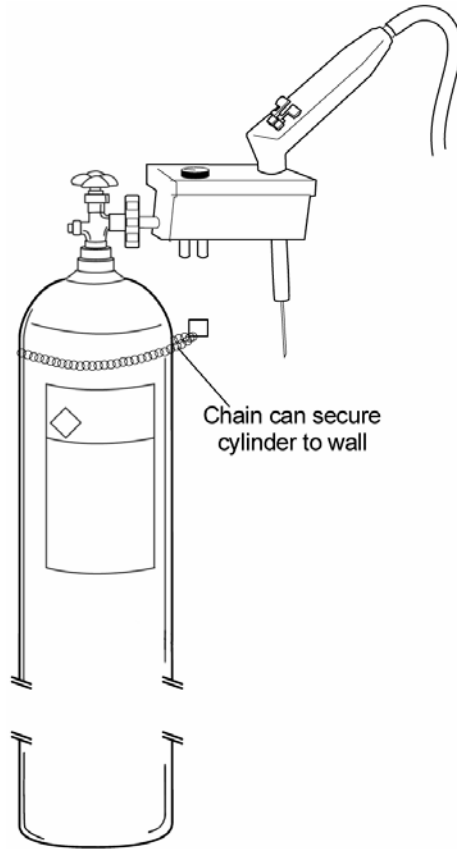
- After the cryotip and plastic sleeve have been high-level disinfected (and rinsed, if appropriate) or sterilized, allow them to air-dry.
- Remove the rubber stopper from the cryotip. Ensure that the inside of the shaft on the cryotip is completely dry before placing the plastic sleeve on the cryotip and reattaching the cryotip to the probe.

## STORAGE

During clinic hours, the cryotherapy system should remain connected to the gas cylinder. At the end of the day, they should be disconnected and stored according to the following guidelines:

- Place the cryotherapy system in its cardboard carrying case (i.e., its original packaging). When the cryotip is not attached to the probe of the cryotherapy unit, the plastic protector tube should be placed on the thin metal tube at the end of the probe (**Figure D-9**).
- Store gas cylinders in an upright position at the location where the system is used. Gas cylinders are very heavy and can cause injury if they fall and strike someone. To prevent possible injuries, do not move the gas cylinders except when necessary. Keep them locked on a cart built specifically for this purpose or chained to the wall (**Figure D-11**).
- Store gas cylinders and the cryotherapy system at room temperature (i.e., between 20–30°C [68–86°F]) and away from sunlight and other heat sources (e.g., radiators, furnaces).
  - Heat increases the pressure of the gas in the cylinder. This pressure can, in turn, damage the cryotherapy unit or break the rupture disk in the safety valve, causing the system to stop working.
  - Cold temperatures increase the amount of time and energy required by the system to “thaw” during a procedure.

**Figure D-11. Gas Cylinder Secured to Wall**





## APPENDIX E

# TROUBLESHOOTING WITH THE CRYOTHERAPY SYSTEM<sup>1</sup>

This section is intended to guide the user in troubleshooting problems commonly encountered when using the Model LL100 cryotherapy system<sup>2</sup> (Wallach Surgical Devices, Inc.). **Table E-1** describes signs of trouble, explains the cause of each, and indicates an appropriate follow-up action aimed at resolving the problem.

**Note:** Solving some of the problems covered in this section requires the knowledge/skills of a technician trained in basic repairs and maintenance of the cryotherapy system (which is beyond the scope of this manual). In such cases, whether it is better to repair the unit onsite, return it to the manufacturer for repairs, or replace the system altogether depends on the resources available at a given site.

**Table E-1. Following-Up on Commonly Encountered Problems**

PROBLEM	POSSIBLE EXPLANATION	APPROPRIATE ACTION
1. Gas is leaking at the point where the regulator attaches to the gas cylinder.	The connection to the cylinder either is not tight enough or requires a washer.	Close the main cylinder valve and remove the regulator. <ul style="list-style-type: none"> <li>• If using a US fitting, re-attach the regulator to the gas cylinder and make sure the connection is tight (<b>Figure D-3</b>, page D-3).</li> <li>• If using a British fitting, place a new washer (Wallach Item #C18072) over the brass nipple and attach the regulator to the cylinder; tighten carefully to avoid tearing (<b>Figure D-3</b>, page D-3).</li> </ul>
2. Gas leaks from the handle.	May be caused by any number of problems (e.g., worn O-rings, broken inlet/ exhaust tube, loose insulator tube).	If qualified to perform basic repairs and maintenance, replace the O-rings (Wallach Item #107500), retainer seals (Wallach Item #200004), and valve cores (Wallach Item #108519). Replace the spring (Wallach Item #111001) only as needed. <p style="text-align: center;">➔ If not qualified or problem not resolved, return the system to the manufacturer.</p>
3. Gas leaks from the hose.	The hose has a hole in it.	Return the system to the manufacturer.

*(table continued on next page)*

<sup>1</sup> Adapted from: Blumenthal P. 2004. *The Model ll10 Cryotherapy System: An Operational and Use Guide to Basic Repair and Maintenance*. JHPIEGO: Baltimore.

<sup>2</sup> In this manual, illustrations and instructions specifically related to the cryotherapy system/unit are based on the Wallach LL100 Cryotherapy System (Wallach Surgical Devices, Inc., 235 Edison Road, Orange, CT 06477, USA. www.wallachsd.com). While the principles of cryotherapy are the same regardless of the system used, other systems may differ in appearance, operating features, and procedures for proper use.

Table E-1. Following-Up on Commonly Encountered Problems (continued)

PROBLEM	POSSIBLE EXPLANATION	APPROPRIATE ACTION
4. Gas leaks from the regulator.	Valves in the regulator are jammed or worn.	Return the system to the manufacturer.
5. When the gas is turned on, the pressure gauge needle moves into the red-shaded area.	The gas pressure in the cylinder is too high.	Vent the cylinder as follows: <ul style="list-style-type: none"> <li>● Close the main cylinder valve.</li> <li>● Slowly disconnect the regulator from the cylinder to release the gas in the hose.</li> <li>● Ensure that the main cylinder valve is not pointing toward anyone.</li> <li>● Slowly open the main cylinder valve just until you can hear gas escaping. Let a small stream of gas escape for 8 to 10 seconds.</li> <li>● Close the cylinder valve.</li> <li>● Reattach the regulator to the cylinder connector (<b>Figure D-3</b>, page D-3).</li> <li>● Open the main cylinder valve again.</li> </ul> → If the pressure is still too high, repeat the procedure.
6. When the gas is turned on, the pressure gauge needle is in the yellow-shaded area (or at or below the gas pressure indication line in the green-shaded area).	The gas pressure in the cylinder is too low.	Replace the cylinder with a full one before proceeding.
7. When turning on the gas from a new cylinder for the first time, there is a loud noise and gas escapes loudly from the safety valve on the regulator. After this, the cryotherapy unit will not work and gas continues to escape.	The gas pressure in the cylinder is too high; the rupture disk in the safety valve broke to release pressure and prevent damage to the cryotherapy system.	Close the main cylinder valve. Remove the regulator and vent the cylinder, as recommended for Problem 5 (above). Then replace the broken rupture disk-nut with a new one as follows: <ul style="list-style-type: none"> <li>● Using a crescent wrench, remove only the end part of the brass safety valve—the hexagonal nut with the two holes in the sides (i.e., the rupture disk-nut, which includes a small rubber O-ring).</li> <li>● Do not remove the entire brass fitting from the body of the regulator.</li> </ul> <p><b>Note:</b> Two crescent wrenches may be required to remove the brass nut, one to prevent the part that is nearest to the regulator from turning and another to remove the end part.</p> <ul style="list-style-type: none"> <li>● Dispose of the old rupture disk-nut.</li> <li>● Install the new rupture disk-nut (Wallach Item #400285). Make sure the small rubber O-ring is on the replacement rupture disk-nut.</li> <li>● Tighten the rupture disk onto the safety valve.</li> </ul>

(table continued on next page)

Table E-1. Following-Up on Commonly Encountered Problems (continued)

PROBLEM	POSSIBLE EXPLANATION	APPROPRIATE ACTION
8. When the freeze trigger is depressed, no gas flows.	Pieces of CO <sub>2</sub> ice have blocked the flow of gas in the inlet/exhaust tube of the cryotherapy unit.	<ul style="list-style-type: none"> <li>• Check gas pressure (Problem 6, above) and, if appropriate, clear the inlet/exhaust tube, as recommended for Problem 11 (below).               <ul style="list-style-type: none"> <li>➔ If the problem is not resolved, proceed as shown below.</li> </ul> </li> <li>• If qualified to perform basic repairs and maintenance, replace the spring (Wallach Item #111001), O-rings (Wallach Item #107500), retainer seals (Wallach Item #200004), and valve cores (Wallach Item #108519).               <ul style="list-style-type: none"> <li>➔ If not qualified or problem not resolved, return the system to the manufacturer.</li> </ul> </li> </ul>
9. When the defrost trigger is depressed, no gas flows.	Pieces of CO <sub>2</sub> ice have blocked the flow of gas in the inlet/exhaust tube of the cryotherapy unit.	<ul style="list-style-type: none"> <li>• Check gas pressure (Problem 6, above) and, if appropriate, clear the inlet/exhaust tube, as recommended for Problem 11 (below).               <ul style="list-style-type: none"> <li>➔ If the problem is not resolved, proceed as shown below.</li> </ul> </li> <li>• If qualified to perform basic repairs and maintenance, replace the spring (Wallach Item #111001), O-rings (Wallach Item #107500), retainer seals (Wallach Item #200004), and valve cores (Wallach Item #108519).               <ul style="list-style-type: none"> <li>➔ If not qualified or problem not resolved, return the system to the manufacturer.</li> </ul> </li> </ul>
10. The freeze and defrost triggers will not move.	The freeze and defrost triggers are jammed or broken.	<p>If qualified to perform basic repairs and maintenance, replace the O-rings (Wallach Item #107500), retainer seals (Wallach Item #200004), and valve cores (Wallach Item #108519). Replace the spring (Wallach Item #111001) only as needed.</p> <ul style="list-style-type: none"> <li>➔ If not qualified or problem not resolved, return the system to the manufacturer.</li> </ul>
11. While performing a cryosurgical procedure using CO <sub>2</sub> , gas flow sputters/stops and the cryotherapy unit stops working.	Pieces of CO <sub>2</sub> ice have blocked the flow of gas in the inlet/exhaust tube of the cryotherapy unit, or there is no more gas.	<ul style="list-style-type: none"> <li>• Check the gas pressure (Problem 6, above).               <ul style="list-style-type: none"> <li>➔ If the gas pressure is normal, proceed as shown below.</li> </ul> </li> <li>• Close the main cylinder valve. Allow the cryotherapy unit to warm up. If the FREEZE (left) trigger remains locked down, there will be a loud, but harmless, “POP” sound when the unit has warmed up enough to thaw the ice and clear the inlet/exhaust tube (about 1 minute). After the “POP” sound, briefly press the DEFROST (right) trigger and then resume the cryosurgical procedure using the freeze-clear-freeze technique (<b>Figure D-7</b>, page D-6).</li> </ul>



## APPENDIX F

# PROCESSING SURGICAL GLOVES<sup>1</sup>

The risk in reusing surgical gloves is that processed gloves contain more invisible tears than new ones and therefore provide less protection to the wearer. Sterilization (autoclaving) and high-level disinfection (steaming or boiling) of gloves, when correctly performed, can provide a high quality product. In addition, **double-gloving** for high-risk procedures can be done. Therefore, processing surgical gloves constitutes an **appropriate reuse of disposable items** where resources are limited (Daschner 1993).

### HOW TO DECONTAMINATE AND CLEAN SURGICAL GLOVES BEFORE STERILIZATION OR HIGH-LEVEL DISINFECTION (HLD)

**STEP 1:** Before removing soiled gloves, immerse hands briefly in a container filled with 0.5% chlorine solution (or other locally available disinfectant).

**STEP 2:** Remove gloves by turning inside out and soak in the chlorine solution for 10 minutes.

(Performing **Steps 1 and 2** insures that both surfaces of the gloves are decontaminated.)

**STEP 3:** Wash gloves in soapy water, cleaning inside and out.

**STEP 4:** Rinse gloves in clean water until no soap or detergent remains. (Residual soap or detergent can interfere with sterilization or HLD.)

**STEP 5:** Test gloves for holes by inflating them by hand and holding them under water. (Air bubbles will appear if there are holes.)

**STEP 6:** Gently air dry gloves inside and out before proceeding with steam sterilization. (Gloves that remain wet for long periods of time will absorb water and become tacky.)

**Note:** Gloves should be discarded after processing three times because invisible tears may occur with additional processing (Bagg, Jenkins and Barker 1990; Martin et al 1988).

---

<sup>1</sup> Adapted from: Tietjen L, W Cronin and N McIntosh. 1992. *Infection Prevention for Family Planning Service Programs: A Problem-Solving Reference Manual*. Essential Medical Information Systems, Inc.: Durant, Oklahoma.

## HOW TO STERILIZE SURGICAL GLOVES

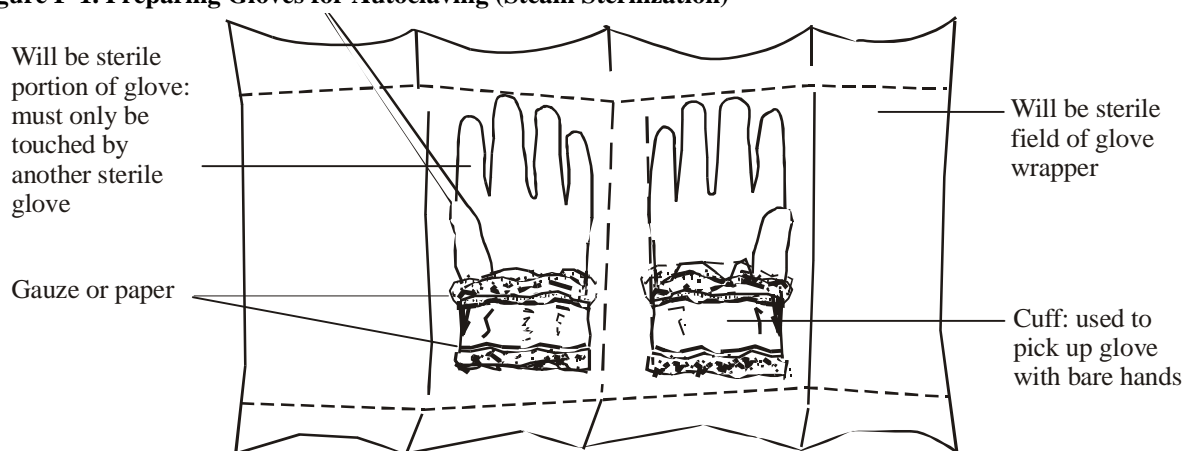
After decontamination, cleaning and drying, gloves must be packaged prior to sterilizing by autoclaving. First, fold the cuffs of the gloves out towards the palm so that they can be put on easily and without contamination after sterilization. Next, put gauze or paper inside each glove and under the fold of the cuff and wrap the gloves as shown in **Figure F-1**. (Do not tie tightly or wrap glove packs with rubber bands.) Finally, place them in a wire basket on their sides to allow optimum steam penetration. (If gloves are stacked in piles, penetration of steam under the cuffs may be poor.) Autoclave at 121°C (250°F) for 30 minutes and at a pressure of 106 kPa (15 lb/in<sup>2</sup>).

---

**Remember:** Higher temperatures and pressures are destructive to gloves.

---

**Figure F-1. Preparing Gloves for Autoclaving (Steam Sterilization)**



Source: South East Asia Office/World Health Organization 1988.

Immediately after autoclaving, gloves are extremely friable and tear easily. Gloves should **not** be used for 24 to 48 hours to allow the elasticity to return and to prevent tackiness (stickiness) (**Table F-1**).

**Table F-1. Tips to Help Avoid Glove Problems**

PROBABLE CAUSE	RECOMMENDED SOLUTION
<b>PROBLEM: TACKY OR STICKY GLOVES</b>	
Residual liquid soap or detergent	Reduce amount of liquid soap or detergent used when washing gloves.  Rinse gloves at least three times in clean water.
Heated to high temperature for too long	Use <b>30 minutes</b> sterilizing time at 121 °C (250 °F) and remove gloves from sterilizer as soon as cycle is completed.
Gloves sterilized with other goods	Sterilize gloves separately.
Gloves not allowed to dry completely after steaming	Wear “wet” within 30 minutes or allow to dry for 4 to 6 hours before using.
Poor powdering	Use absorbable glove powder and follow manufacturer’s instructions to insure a film of powder on all surfaces.
Surfaces of gloves touching each other	Gauze or paper wicks should be inserted between the palm and back of hand of each glove and between the hand of the glove and the turned-back cuff. This allows steam to contact all surfaces during sterilization and prevents surfaces from adhering to each other.
Breakdown (deterioration) of rubber (latex)  (Rubber gloves deteriorate while stored even though they have not been used. They become soft, sticky and unusable.)	Store in a dry, cool area. Do not store in direct sunlight.
<b>PROBLEM: EXCESSIVE TEARING OR RUPTURING</b>	
Gloves used too soon following sterilization	<b>Do not</b> use gloves for 24 to 48 hours after sterilization. This allows gloves to regain their elasticity before use.

Source: Tomlinson 1991.

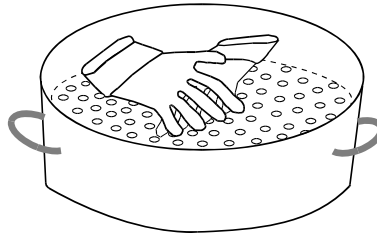
## HOW TO HIGH-LEVEL DISINFECT SURGICAL GLOVES BY STEAMING

After gloves have been decontaminated and thoroughly washed, they are ready for HLD by steaming (McIntosh et al 1994). (See **Appendix C** for more information on steaming.)

**STEP 1:** Fold up the cuffs of the gloves so that they can be put on easily and without contamination after HLD.

**STEP 2:** Place gloves into one of the steamer pans with holes in its bottom. To make removal from the pan easier, the cuffs should be facing outward toward the edge of the pan (**Figure F-2**). Five to fifteen pairs can be put in each pan depending on the size (diameter) of the pans.

**Figure F-2. Gloves in Steamer Pan**



**STEP 3:** Repeat this process until up to three steamer pans have been filled with gloves. Stack the filled steamer pans on top of a bottom pan containing water for boiling. A second (empty) pan without holes should be placed on the counter next to the heat source (see **Step 9**).

**STEP 4:** Place lid on top pan and bring water to a full **rolling** boil. (When water only simmers, very little steam is formed and the temperature may not get high enough to kill microorganisms.)

---

**Remember:** Be sure there is sufficient water in the bottom pan for the **entire** 20 minutes of steaming.

---

**STEP 5:** Reduce heat so that water continues to boil at a rolling boil. (When water boils too violently, it evaporates quickly and wastes fuel.)

**STEP 6:** When steam begins to come out between pans, start timer or note time on clock and record time in the HLD log.

**STEP 7:** Steam gloves for 20 minutes.

**STEP 8:** Remove top steamer pan and place cover on pan remaining on the top of the stack. Gently shake excess water from the gloves in the pan just removed.

---

**Remember:** Do **not** place pans containing gloves on a table top, counter or other surface as gloves will be contaminated.

---

**STEP 9:** Place pan containing gloves on the second (empty) pan (see **Step 3**). Repeat until all pans containing gloves are restacked on this empty pan. (This step allows the gloves to cool and dry without becoming contaminated.)

**STEP 10:** Allow gloves to air dry in the steamer pans (4 to 6 hours) before using.<sup>2</sup>

**STEP 11:** Using a high-level disinfected forceps, transfer the dry gloves to a dry, high-level disinfected container<sup>3</sup> with a tight-fitting lid. Store for up to 1 week. (Gloves also can be stored in the stacked and covered steamer pans.)

## REFERENCES

Bagg J, S Jenkins and GR Barker. 1990. A laboratory assessment of the antimicrobial effectiveness of glove washing and re-use in dental practice. *Journal of Hospital Infection* 15(1): 73–82.

Daschner F. 1993. The hospital and pollution: Role of the hospital epidemiologist in protecting the environment, in *Prevention and Control of Nosocomial Infections*, Second edition. Wenzel RP (ed). Williams & Wilkins: Baltimore, Maryland.

Martin MV et al. 1988. A physical and microbial evaluation of the re-use of non-sterile gloves. *British Dental Journal* 165(9): 321–324.

McIntosh N et al. 1994. *Practical Methods for High-Level Disinfection of Surgical Gloves*. Paper presented at American Public Health Association Annual Meeting. Session no. 2285, Washington, DC, October 31–November 4.

Perkins JJ. 1983. *Principles and Methods of Sterilization in Health Sciences*, Second edition. Charles C. Thomas: Springfield, Illinois.

Sorensen KC and J Luckman. 1979. Basic Nursing: A Psychophysiologic Approach, 934–938. WB Saunders Co.: Philadelphia, Pennsylvania.

South East Asia Office (SEARO)/World Health Organization (WHO). 1988. Manual on Infection Control in Health Facilities. SEARO Regional Health Papers No. 18: New Delhi, India.

Tietjen LG, W Cronin and N McIntosh. 1992. *Infection Prevention for Family Planning Service Programs: A Problem-Solving Reference*

---

<sup>2</sup> Alternatively, allow gloves to cool for 5 to 10 minutes before wearing “wet.” Gloves should be used within 30 minutes, if possible. After this time, the fingers of the gloves stick together and the gloves are hard to put on despite being damp. Gloves that have been removed from the steamer pan(s) to be worn “wet” but were not used during the clinic session should be reprocessed before using.

<sup>3</sup> To prepare a high-level disinfected container, boil (if small) or fill a plastic container with 0.5% chlorine solution and soak for 20 minutes. (The chlorine solution can then be transferred to another container and reused.) Rinse the inside thoroughly.

*Processing Surgical Gloves*

*Manual.* Essential Medical Information Systems, Inc.: Durant, Oklahoma.

Tomlinson M. 1991. Personal reference. Chosen Mission Project: Erie, Pennsylvania.

## APPENDIX G

# PERFORMING BREAST AND PELVIC EXAMINATIONS<sup>1</sup>

## INTRODUCTION

Having regular breast and pelvic examinations is an important part of improving every woman's health. They can help identify problems before a woman has any symptoms and provide an opportunity for early treatment or prevention (e.g., breast or cervical cancer). These examinations also give the healthcare provider the opportunity to talk with the woman about her health and allow appropriate counseling if her lifestyle puts her health at risk. For example, if during an examination the provider finds that a woman has multiple sex partners, she should be counseled about the risk of this behavior and advised to use a condom during sexual intercourse. In addition, having regular breast and pelvic examinations helps the woman to learn about her body. Finally, healthcare providers often need to perform pelvic examinations before they give some family planning methods (e.g., IUD) in order to be sure the method is appropriate for the woman.

## PURPOSE

- To look at the breasts and check for differences in shape or size or other abnormalities
- To check the lower abdomen and groin for abnormalities
- To look at the external genitalia and check the Bartholin's and Skene's glands for discharge
- To look at the vagina and cervix for infection, tears or other abnormalities (e.g., polyps, cancer)
- To check the pelvic organs (uterus, fallopian tubes and ovaries) for infection and abnormalities

---

<sup>1</sup> Adapted from: Schaefer L, N McIntosh and A Blouse (eds). 2000. *Guidelines for Performing Breast and Pelvic Examinations*. JHPIEGO: Baltimore, Maryland.

## **BEFORE STARTING**

To make these guidelines easy to use, the text follows the order in which the examinations are performed. The essential, need-to-know information for each examination is organized under the headings:

- Preparation
- Procedure

## **TIPS WHEN PERFORMING BREAST AND PELVIC EXAMINATIONS**

- Be sensitive to the woman by giving her opportunities to express any concerns before and during the examination.
- Always respect the woman's sense of privacy (e.g., draw the curtains around the examining table, close the door or cover the window in the examination room).
- Speak in a calm, relaxed voice at all times and encourage the woman to ask questions at any time.
- If the woman is anxious, assure her that you will do your best to make the examination comfortable.
- Discuss what you are going to do at each step, show her what you are going to do (e.g., let her see the speculum and explain its use), discuss what you find throughout the examination and be sure she clearly understands your findings and what they mean for her.
- Throughout the examination, approach the woman slowly and avoid any sudden or unexpected movements.
- Do not rush through the examination. Perform each step gently and ask her if she is having any discomfort during any part of the examination. Be aware of her facial expressions and body movements as indications that she is uncomfortable.
- Always take into consideration any cultural factors when deciding what clothing the woman should remove. Have a clean sheet or drape to cover the woman's breast or pelvic area if needed.

Knowing that the examinations will be performed by a caring and competent provider may encourage the woman to continue coming to the clinic for her reproductive health needs.



This symbol alerts the provider to useful **information** or **suggestions** for making the examination easier to perform or more comfortable for the woman.

To assist the provider in talking with women about these reproductive health examinations, there is a short section called **Most Commonly Asked Questions** at the end of the breast and pelvic examination sections.

## GETTING READY<sup>2</sup>

- These examinations should be performed in a clean, well-lit, private examination or procedure room that has a source of clean water.
- If a pelvic examination will be performed, before asking the woman to undress, **check** to be sure she has:
  - emptied her bladder, and
  - thoroughly washed and rinsed her abdominal and genital area with soap and water if her hygiene is poor.
- The woman should be asked to remove only enough clothing to complete the examinations. For example:
  - For the breast examination she should remove her upper garments.
  - For the pelvic examination she should remove any lower undergarments.

Because she will need to expose her abdomen during the pelvic examination, she may have to remove or loosen her outer garments as well.

- Help her onto the table and make sure she is comfortable. If necessary, ask her to take a few deep breaths to help her relax.
- Wash your hands thoroughly with soap and water and dry them with a clean, dry cloth or allow them to air dry before beginning the examination.

## PERFORMING A BREAST EXAMINATION

It is important that the provider be sensitive to the woman's feelings and concerns **before, during** and **after** performing a breast examination. She may be embarrassed or not want to have the examination because she will need to show her breasts. The healthcare provider also may be uncomfortable at first. A calm and caring manner will help reassure the woman.

---

<sup>2</sup> A female assistant should be available to chaperone the woman when a male clinician is the examiner.

**In this section, you will learn:**

- How to examine both breasts and nipples for changes in shape or size, dimpling or puckering of the skin, and nipple discharge
- How to check both breasts and axilla for thickening, fluid-filled cysts or masses (tumors)

**Preparation**

- Tell her you are going to examine her breasts.



This is a good time to ask if she has noted any changes in her breasts and whether she does monthly breast self-examinations. Tell the woman that you will show her how to do a breast self-examination before she leaves.

- With the woman undressed from the waist up, have her sit on the examining table with her arms at her sides.

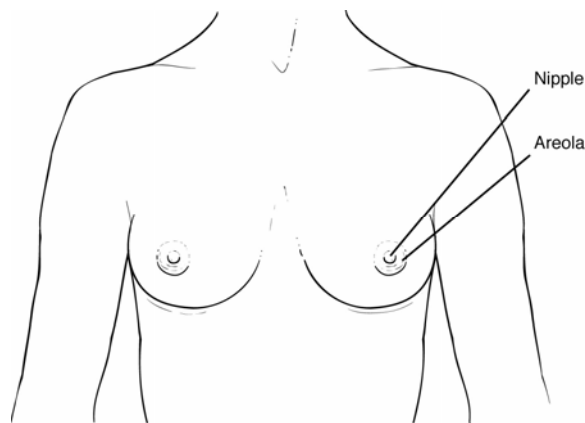


If there are open sores or nipple discharge, put new examination or high-level disinfected surgical gloves on both hands.

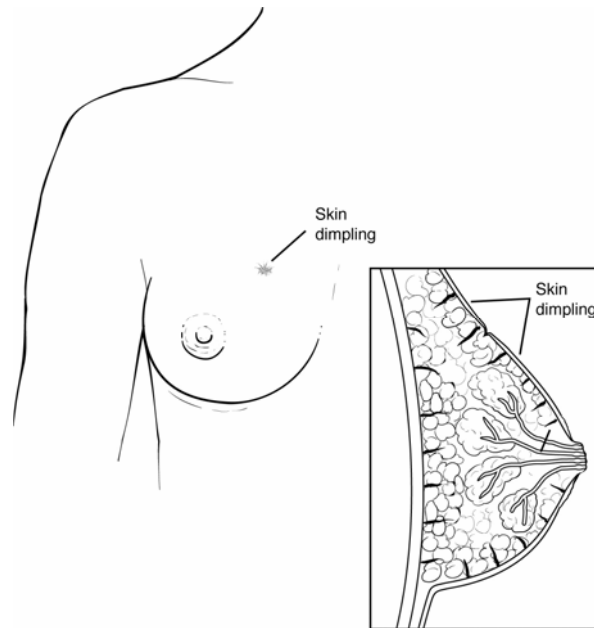
**Procedure**    *Inspection*

- Look at the breasts for shape and size (**Figure G-1**). Note any difference in shape, size, nipple or skin puckering or dimpling (**Figure G-2**). Although some difference in size of the breasts is normal, irregularities or difference in size and shape may indicate masses. Swelling, increased warmth or tenderness in either breast may suggest infection, especially if the woman is breastfeeding.

**Figure G-1. Appearance of Breasts (Hands at Sides)**

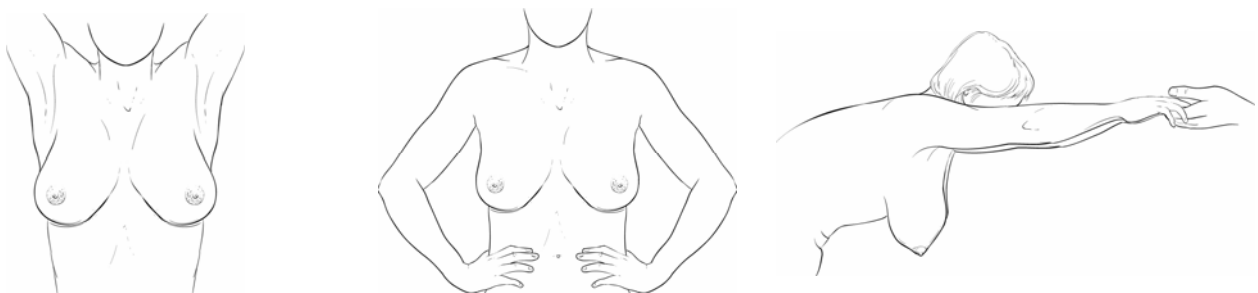


**Figure G-2. Breast Puckering or Dimpling**



- Look at the nipples and note their size and shape and the direction in which they point (e.g., do her breasts hang evenly?). Also check for rashes or sores and any nipple discharge.
- Have the woman first raise her arms over her head (**Figure G-3a**) and then press her hands on her hips to contract her chest wall (pectoral) muscles (**Figure G-3b**). In each position, inspect the size, shape and symmetry, nipple or skin puckering or dimpling of the breast and note any abnormalities. (These positions will also show skin puckering or dimpling if either is present.) Then have the woman lean forward to see if her breasts hang evenly (**Figure G-3c**).

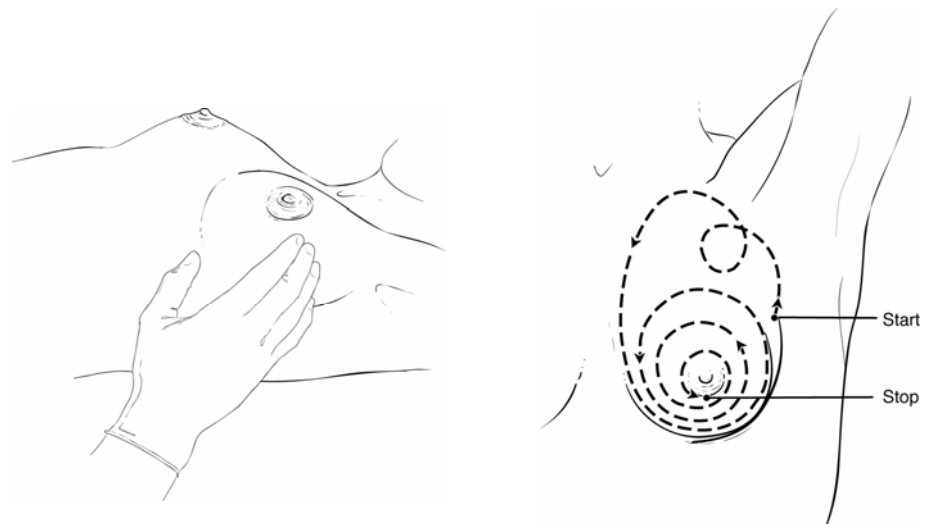
**Figure G-3a, b and c. Appearance of Breasts (left to right): Arms over Head, Hands on Hips, Leaning Forward**



***Palpation***

- Have the woman lie down on the examining table.
- ✓ Placing a pillow under her shoulder on the side being examined will spread the breast tissue and may help in examining the breast.
- ✓ Place a clean sheet or drape over the breast you are not examining.
  - Place the woman's left arm over her head. Look at the left breast to see if it looks similar to the right breast and whether there is puckering or dimpling.
  - Using the pads of your three middle fingers (**Figure G-4a**), palpate the breast using the spiral technique. Start at the top outermost edge of the breast (**Figure G-4b**). Press the breast tissue firmly against the ribcage as you complete each spiral and gradually move your fingers toward the areola. Continue this until you have examined every part of the breast. Note any lumps or tenderness.
- ✓ Wetting your fingertips with dilute soap solution or betadine may help you identify small lumps or axillary nodes.

**Figure G-4a and b. Spiral Technique of Breast Examination**



- Using the thumb and index finger, **gently** squeeze the nipple of the breast (**Figure G-5**). Note any discharge: clear, cloudy or bloody. Any cloudy or bloody discharge expressed from the nipple should be noted in the woman's record. Although it is normal to have some cloudy discharge from either or both breasts up to a year after giving birth or stopping breastfeeding, rarely it may be due to cancer, infection or a benign tumor or cyst.

**Figure G-5. Checking for Nipple Discharge (Left Breast)**



- Repeat these steps for the right breast.
- If there is any doubt about your findings (e.g., whether there is a lump) repeat the steps with the woman in a sitting position with her arms at her sides.
- To palpate the tail of the breast, have the woman sit up and raise her left arm to shoulder level. If needed, have her rest her hand on your shoulder. Press along the outside edge of the pectoral muscle while gradually moving your fingers up into the axilla to check for enlarged lymph nodes or tenderness (**Figure G-6**). It is essential to include the tail of the breast in the palpation because this is where most cancer occurs.

**Figure G-6. Checking the Axilla (Left Breast)**



- Repeat this step for the right side.
- After completing the examination, have the woman cover herself. Explain any abnormal findings and what, if anything, needs to be done. If the examination is entirely normal, tell her everything is normal and healthy and when she should return for a repeat examination (i.e., annually or if she finds any changes on breast self-examination).

- Show the woman how to perform a breast self-examination (see below).
- Record your findings.

**Recording the Findings**

After performing the breast examination, write the findings in the woman's record. An example of the findings from a normal examination is shown below.

Breasts                      Appeared normal. No nipple discharge. No lumps or tenderness found during palpation. Axilla normal.

***Terms Used to Describe the Findings***

Specific terms used to describe the findings are listed below. When recording the findings, use as many of these terms as possible so that the woman's record will have enough detail.

Shape                      Is there any difference in the shape of the breasts?

Skin                        What does the skin look like? Is it smooth, puckered or dimpled?

Nipple Discharge        Is there any abnormal fluid coming from the nipples? Discharge is described by its color, thickness, odor and amount.

Mass or Lump              A group of cells that adhere to each other. May be the result of an abscess, cyst, or benign or malignant tumor.

Size                        How big (cm) is the mass? If the mass is round, what is the diameter?

Consistency              What does the mass or lump feel like? Is it firm, soft, fluid-filled or hardened?

Mobility                    When palpated, is the mass movable or does it stay fixed? Mobility is usually defined in terms such as fixed (does not move on palpation), freely mobile (mobility on palpation) and limited mobility (some movement on palpation).

## **BREAST SELF-EXAMINATION (BSE)**

Most breast lumps are found by women themselves. By examining her breasts every month, a woman will know how her breasts normally look and feel. If there is a change in her breasts, she will be able to see it and let her healthcare provider know. Teaching women how to examine their breasts every month and encouraging them to do so are important to maintaining good health (**Figure G-7**).

### **Instructions for Breast Self-Examination**

#### *When to Examine Your Breasts*

- It is best to examine your breasts **7–10 days after the first day** of the menstrual period. (This is the time when the breasts are less likely to be swollen and tender.) **You should examine your breasts every month, even after your menstrual period has stopped forever.** If you are no longer menstruating, you should pick the same day each month (e.g., the first day of the month) to examine your breasts.
- Breast self-examination can be done after bathing or before going to sleep. Examining your breasts as you bathe will allow your hands to move easily over your wet skin.

#### *How to Examine Your Breasts*

First, **look** at your breasts.

- Stand in front of a mirror with your arms at your sides and look for any changes in your breasts. Note any changes in their size, shape or skin color or if there is any puckering or dimpling.
- Look at both breasts again, first with your arms raised above your head and then with your hands pressed on your hips to contract your chest muscles. Bend forward to see if both breasts hang evenly.
- **Gently** squeeze each nipple with the thumb and index finger to look for any discharge.

Then, **feel** your breasts.



You may examine your breasts while standing up or lying down. If you examine your breasts while lying down, it will help to place a folded towel or pillow under the shoulder of the breast you are examining.

- Raise your left arm over your head. Use your right hand to press firmly on your left breast with the flat surface (fat pads) of your three middle fingers. Start at the top of the left breast and move your fingers around the entire breast in a large spiral or circular motion. Feel for any lumps or thickening. Continue to move around the breast in a spiral direction and inward toward the nipple until you reach the nipple.

### *Performing Breast and Pelvic Examinations*

- Be sure to check the areas between the breast and the underarm and the breast and the collarbone.
- Raise your right arm over your head and repeat the examination for the right breast.

### *What to Look for When Examining Your Breasts*

- A change in the size or shape of the breast.
- A puckering or dimpling of the breast skin.
- A lump or thickening in or near the breast or underarm area. If the lump is smooth or rubbery and moves under the skin when you push it with your fingers, do not worry about it. But if it is hard, has an uneven shape and is painless, especially if the lump is in only one breast and does not move even when you push it, you should report it to your healthcare provider.

If your breasts are usually lumpy, you should note how many lumps you feel and their locations. Next month, you should note if there are any changes in the size or shape (smooth or irregular). Using the same technique every month will help you know if any changes occur.

- Any nipple discharge that looks like blood or pus, especially if you are not breastfeeding, should be reported to your healthcare provider.



There may be some discharge from one or both breasts for up to a year after having a baby or stopping breastfeeding.

**Figure G-7. Breast Self-Examination**



## **MOST COMMONLY ASKED QUESTIONS ABOUT BREAST EXAMINATIONS**

**What is a breast examination?** A breast examination is looking at the size and shape of both breasts, feeling the breast tissue and checking to see if you have any fluid leaking from either nipple.

**Why do I need a breast examination?** The breast examination ensures that your breasts are normal. It also helps your healthcare provider find any medical conditions (such as infections or tumors) that could become serious if not treated. Many healthcare providers recommend that you have breast examinations regularly when you become sexually active or by 18 years of age.

**How common is breast cancer?** Breast cancer is a leading cause of cancer deaths in women throughout the world (age standardized rate for world population is 13/100,000<sup>3</sup>). Factors that appear to increase the likelihood of developing breast cancer include:

- Age over 40
- Mother or sister with breast cancer
- Menarche prior to age 12
- No children or children only after age 30
- History of breast biopsies
- Overweight

**What are the warning signs?** The changes that can be seen by looking at the breasts are:

- Unusual increase in the size of one breast
- One breast hangs unusually lower
- Puckering of the skin
- Dimpling or puckering of a nipple or areola
- Swelling in upper arm
- Change in the appearance of a nipple
- Milky or bloody discharge from a nipple

The changes that can be found by examining the breast are:

- Lump in the breast
- Enlargement of lymph nodes in axilla or neck

**Will the breast examination hurt?** The breast examination will not hurt. Other than being uncomfortable because someone else is touching your breasts, there should be no pain or discomfort.

---

<sup>3</sup> Parkin DM, P Pisani and J Ferlay. 1999. Estimates of worldwide incidence of 25 major cancers in 1990. *International Journal of Cancer* 80: 827–841.

**I feel scared to have a breast examination. Do other women feel this way?**

It is normal to feel uncomfortable, embarrassed or scared during this examination. Many women complain that the most uncomfortable part of the examination is that it is embarrassing to show their breasts to a healthcare provider. It may help to remember that your healthcare provider is highly trained in performing these examinations. To make you feel more comfortable, you can have someone with you, such as your mother or close girlfriend, during the examination.

**Do I have to take off my clothes?**

You will be asked to remove your outer clothes, including your bra, from the waist up. You can undress in privacy and cover yourself with a cloth sheet or drape before your healthcare provider comes in for the examination.

**Can I see what is happening during the breast examination?**

Yes, it is important that you watch how your breasts are examined and listen carefully to what the healthcare provider says. You will also have the opportunity to learn how to perform breast self-examination.

**How long will the breast examination take?**

Usually the breast examination takes no more than 2–3 minutes. It takes an additional 5–10 minutes to teach you how to perform breast self-examination.

**What is breast self-examination?**

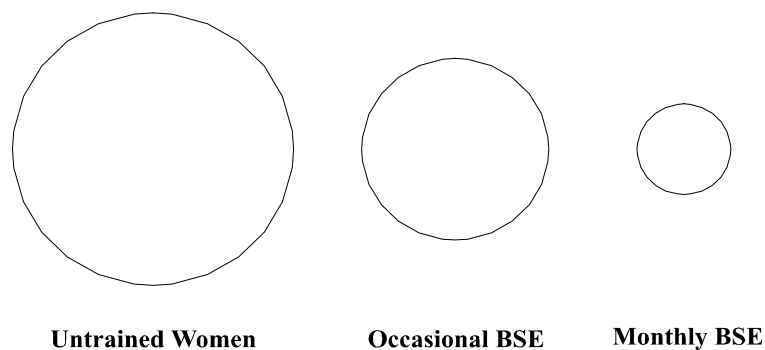
Breast self-examination (BSE) is learning to look at and examine your own breasts each month. Doing this on a regular basis helps reassure you that you are healthy.

**Why is doing monthly breast-self examinations important?**

By doing monthly BSE, you also will have the best chance of finding a lump or other problem at the earliest stage (i.e., when it is small), and when treatment, if needed, will be the most effective and easiest to provide.

As shown below (**Figure G-8**), women trained in BSE can detect smaller lumps than those who are not.

**Figure G-8. Average Size of Lumps Detected**



*Source:* Spence 1994.

## **PERFORMING A PELVIC EXAMINATION**

The steps in performing a pelvic examination include:

- examining the abdomen and groin;
- inspecting the external genitalia;
- performing the speculum and bimanual examinations; and
- performing the rectovaginal examination, if necessary.

## **LOWER ABDOMINAL AND GROIN EXAMINATION**

In this section, you will learn:

- How to check for lower abdominal scars, tenderness or guarding, masses or other abnormalities
- How to check the groin for tenderness, swollen lymph nodes (buboes), open sores or other evidence of STIs

### **Preparation**

- Be sure the woman has emptied her bladder.
- Check that she has thoroughly washed and rinsed her abdominal and genital area with soap and water if her hygiene is poor.
- Ask the woman to remove any lower undergarments.



If a cloth sheet or drape is not available, do not have the woman undress completely, but ask her to loosen her clothing and remove only her undergarments.

- If available, place a rubber sheet on the examining table where the woman's buttocks will rest.
- Have the woman lie on her back on the examining table with her arms at her sides.



Placing a small pillow (if available) under her head and another under her knees may help relax her abdominal muscles. Do not place her hands above her head or folded across her chest. This will stretch and tighten the abdominal muscles, making palpation difficult.

- Expose the entire abdomen, from the base of the rib cage to the pelvic bone. The groin should be visible, but keep the external genitalia covered.

**Examining the  
Abdomen**

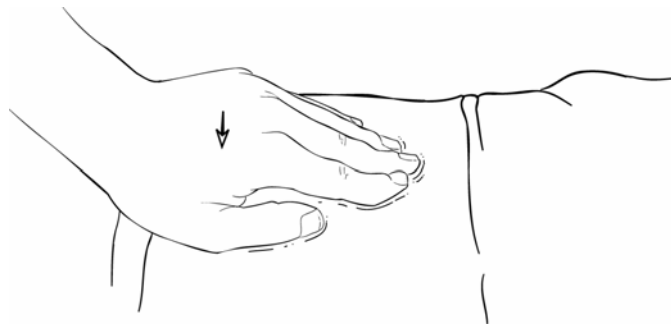
**Inspection**

- Standing to one side of the woman, look at the abdomen.
  - Note whether the abdomen is flat, rounded, distended or sunken.
  - Note the location and contour or shape of the navel (umbilicus). Look for swellings or bulges that may suggest an umbilical hernia. To make the bulge more evident, ask the woman to strain slightly or cough.
  - Look for bulges or visible masses of the abdomen that may indicate pregnancy, tumors, enlarged organs, or fluid or gas presence.
- Check the skin for:
  - Abnormal coloring such as a yellow tone, which may be a sign of jaundice, a blue tone (cyanosis) or areas of redness (inflammation). These may not be easy to see in dark-skinned women.
  - Scars: Record their location and whether the scar is fixed or moves freely.
  - Stretch marks (striae).
  - Rashes and lesions.

**Palpation**

- Before palpating the abdomen, ask the woman if she has any abdominal pain or discomfort. If she does, ask her to point to these areas. Examine these areas last.
- Use light pressure to feel all areas of the abdomen (**Figure G-9**). The abdomen should feel smooth and be soft.

**Figure G-9. Palpating the Abdomen**



## *Performing Breast and Pelvic Examinations*

✓ While you are palpating the abdomen, watch the woman's facial expressions and body movements as possible indications of tenderness.

- Continue to use the pads of your fingertips to palpate all areas of the abdomen.
- Use deeper palpation to determine the size, shape, consistency, tenderness, mobility and movement with respiration of any masses.
- Record any masses, areas of tenderness or increased muscular resistance, and record your findings with reference to the abdominal quadrant in which they are located.

✓ Ask the woman to take a deep breath to help relax the abdominal wall. As she breathes out, you should be able to push the abdomen down more deeply.

- Identify any tender areas. **Guarding** or involuntary abdominal rigidity (muscular resistance) occurs when a tender area is palpated. If more severe tenderness is present, the woman may have guarding and **rebound** (or release) tenderness. In this instance she will feel sharp, stabbing pain when you remove your fingers after deep palpation.

✓ To check for rebound tenderness, press in firmly and slowly and then quickly withdraw your fingers. Guarding and rebound tenderness suggest intra-abdominal abnormalities (e.g., pelvic inflammatory disease or ectopic pregnancy).

✓ When deep palpation is difficult due to obesity, muscular resistance or other reasons, use two hands, one on top of the other. Press down with the upper hand while palpating with the bottom hand.

### **Examining the Groin**

- If there are open sores, put new examination or high-level disinfected surgical gloves on both hands before examining the groin.
- Palpate both groin areas for bumps, swollen lymph nodes (buboes) or swelling.
- If gloves were used, immerse both gloved hands in 0.5% chlorine solution, then remove gloves by turning them inside out. If disposing of gloves, place in a leakproof container or plastic bag. If reusing gloves, submerge in 0.5% chlorine solution for 10 minutes for decontamination.
- Wash hands thoroughly and dry them with a clean, dry cloth or allow them to air dry.

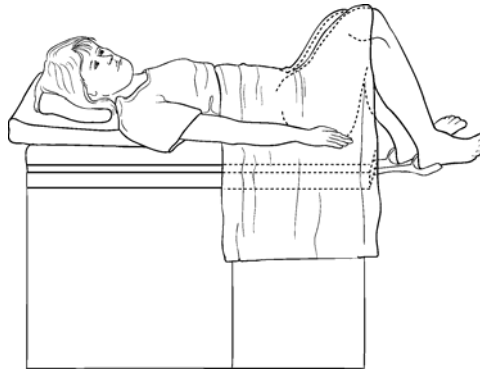
## **EXTERNAL GENITAL EXAMINATION**

In this section, you will learn:

- How to examine the labia, clitoris and perineal area for lesions or scars or sores or warts (condyloma accuminata) and the pubic hair for pubic nits or lice
- How to check for tenderness, swelling, or discharge from Bartholin's or Skene's (paraurethral) glands

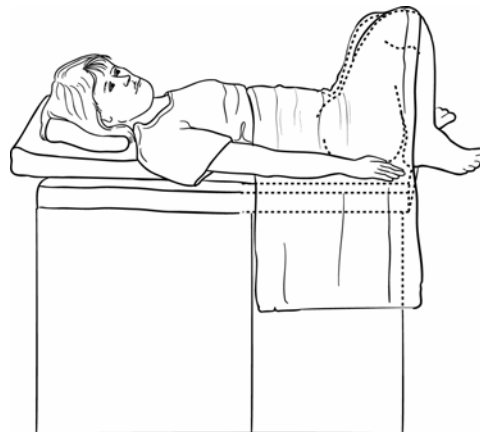
- Preparation**
- If you are using a table with stirrups or footrests, help the woman place her heels in them. Ask her to move toward the end of the examining table until her buttocks extend slightly beyond the edge of the table. Then, ask her to let her knees fall open and to relax her buttocks (**Figure G-10**).

**Figure G-10. Woman Positioned for Pelvic Examination on Table with Stirrups**



- If there are no stirrups, help place her feet on the outside edge of the end of the table and place her buttocks close enough to her feet so that her knees bend upward and fall open comfortably (**Figure G-11**).

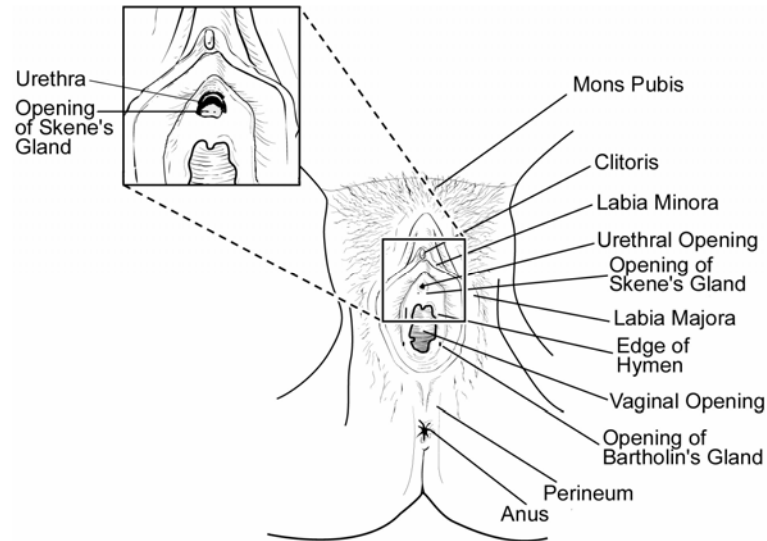
**Figure G-11. Woman Positioned for Pelvic Examination on Table without Stirrups**



**Examining the External Genitalia**

- If she prefers, cover her knees with the drape. The drape can also be placed flat across her abdomen so that you can make eye contact with the woman and she can see what you are doing.
- Wash your hands thoroughly with soap and water and dry them with a clean, dry cloth or allow them to air dry before beginning the examination.<sup>4</sup>
- Turn on the light and direct it so that it shines on the genital area.
- Put new examination or high-level disinfected surgical gloves on both hands.
- Seat yourself comfortably so that you can look at the external genitalia easily.
- Touch the inside of her thigh gently before touching any of the genital area so that you do not startle her.
- Inspect the external genitalia (**Figure G-12**).
  - Look at the thighs for rashes and lesions.
  - Look at the pubic area for lice.
  - Look at the vaginal opening and perineum for rashes, sores and warts (condyloma accuminata).

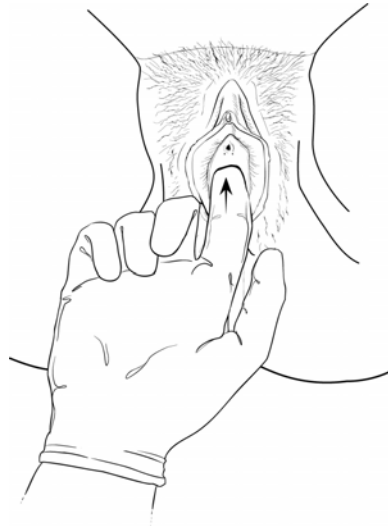
**Figure G-12. External Genitalia**



<sup>4</sup> If hands were washed following groin examination, then omit this step.

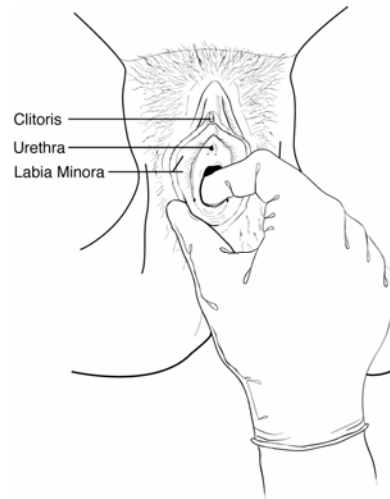
- Separate the labia majora with two fingers and look at the labia minora, clitoris, urethral opening and vaginal opening (**Figure G-12**).
  - Palpate the labia minora between the thumb and second finger.
  - Look for redness (inflammation) discharge, tenderness, ulcers or blisters.
  - Feel for irregularities or lumps (nodules).
- Check for discharge and tenderness of the Skene's glands and urethra (**Figure G-13**).
  - Do this on each side of the urethra and then directly under the urethra.
  - If a discharge is present, take a smear for Gram's stain and tests for gonorrhea and chlamydia (if laboratory facilities are available).

**Figure G-13. Checking the Skene's Glands**



- Check the Bartholin's glands (**Figure G-14**).
  - Using your finger and thumb, palpate each side for any swelling or tenderness.
  - If a discharge is present, take a smear for Gram's stain and tests for gonorrhea and chlamydia (if laboratory facilities are available).

Figure G-14. Checking the Bartholin's Glands



- Ask the woman to bear down while you hold the labia open and watch for any bulging of the anterior or posterior vaginal walls. (Bulging of the anterior vaginal wall indicates cystocele; bulging of the posterior wall is due to a rectocele. If the cervix pushes out through the vaginal opening, this is a uterine prolapse.)
- Look at the perineum.
  - The surface should be thick and smooth in a nulliparous woman; it will be thinner and rigid in a multiparous woman.
  - The anal skin is more darkly pigmented, and may look coarse. There should not be any scarring, lesions, inflammation, lumps, stretch marks, cracks or tears in the skin.



If there are open sores in this area, change gloves before doing the speculum and bimanual examinations. Doing this will avoid introducing fecal microorganisms, especially *E. coli*, into the vagina.



These gloves **cannot be reused**. Immerse both gloved hands in 0.5% chlorine solution, remove the gloves by turning them inside out and place in a leakproof container or plastic bag. Then, wash and dry your hands before putting on another pair of gloves.

## SPECULUM EXAMINATION

In this section, you will learn:

- How to look for vaginal or cervical discharge, tears, ulcers or other abnormalities such as cervical lesions (cervicitis or cervical cancer)
- How to take specimens for diagnostic studies (if appropriate and available)

- How to check for any condition(s) that may require management (e.g., absence of IUD strings) or to evaluate results of treatment (e.g., antibiotics for cervicitis)

**Preparation**

- Once the woman is prepared for the external genitalia examination, no further preparation is necessary.
- If it was necessary to dispose of your gloves following the external genitalia examination, wash your hands with soap and water and dry with a clean cloth or allow to air dry. Put a new pair of examination or high-level disinfected surgical gloves on both hands.

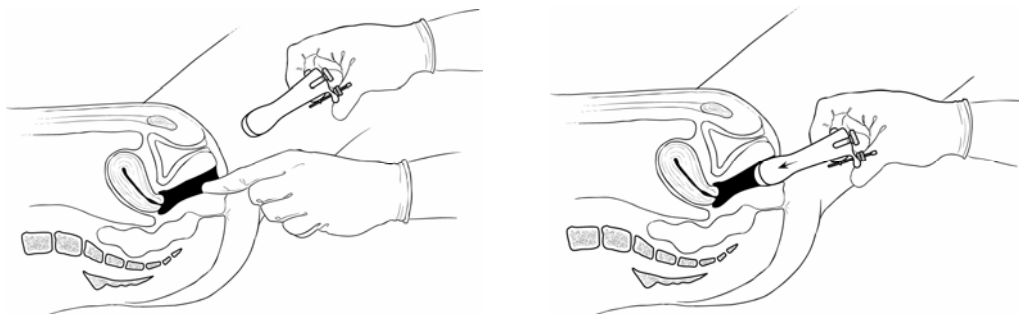
**Performing a Speculum Examination**

- Select the **smallest** bivalve speculum that will allow you to see the vagina and cervix adequately.
- Before inserting the speculum, show it to the woman and explain that you are going to insert part of it into her vagina.
- When inserting the speculum, ask the woman to breathe in deeply and then breathe out slowly through her mouth. This will help her to relax and not contract her vaginal muscles.
- To insert the speculum:
  - Gently insert the index finger of one hand just inside the vaginal opening and push down firmly on the perineum towards the rectum. (This relaxes the vaginal muscles and makes it easier to insert the speculum.) If the vagina is dry, lubricate the blades of the speculum with water before insertion.
  - With your other hand, hold the closed speculum so that the closed blades are in a vertical plane and at a slightly oblique angle (**Figure G-15a**).
  - As you gently insert the speculum into the vagina in a posterior direction, remove your index finger (**Figure G-15b**). Doing this avoids pressure on the urethra, which is painful.



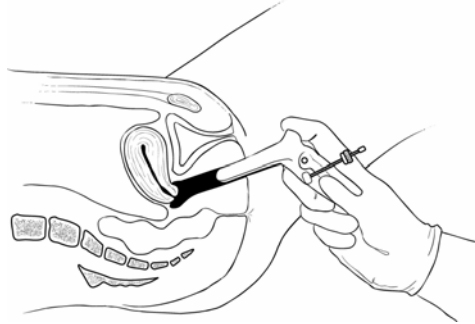
Be careful not to pull on the pubic hair or pinch the labia with the speculum.

**Figure G-15a and b. Inserting the Speculum**



- As you advance the speculum, gently rotate the blades into a horizontal position with the handle down (**Figure G-16**). Be sure the labia do not fold inward while advancing the speculum. Insert it fully or until resistance is felt.

**Figure G-16. Rotating the Speculum**

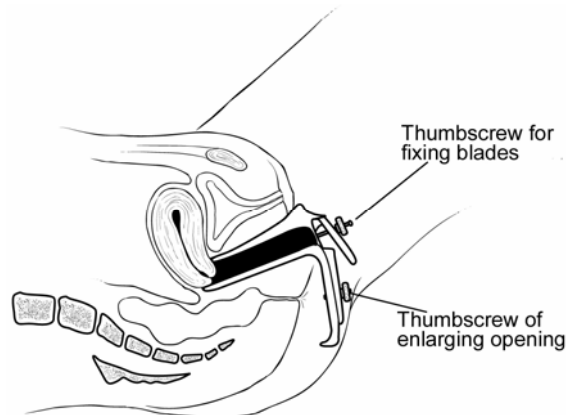


- Gently open the blades (**Figure G-17**) until the cervix comes into full view (**Figure G-18**); then fix the blades in the open position by tightening the upper thumbscrew.

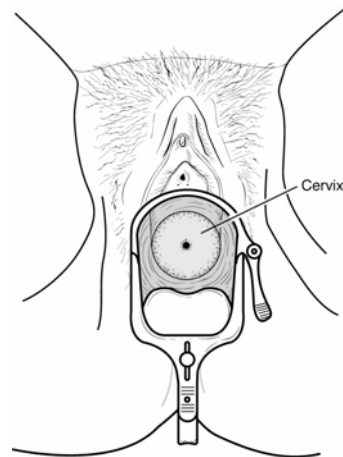


If you are having difficulty locating the cervix, withdraw the speculum slightly, move the speculum so that it points more posteriorly and gently advance the speculum again. Open the blades slowly to see if the cervix has come into view.

**Figure G-17. Opening the Speculum Blades**



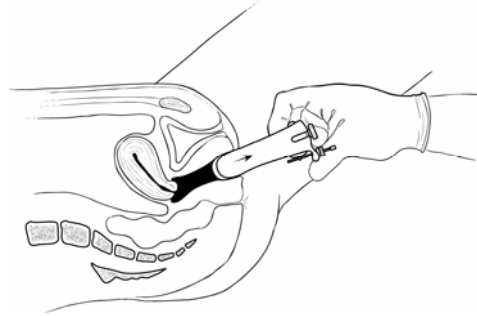
**Figure G-18. Speculum in Place with Blades Open**



- Look at the vaginal walls:
  - The mucosa should be pink in color with a moist and smooth or folded (rugae) surface. Note any inflammation, ulcers or sores. Normal secretions are usually thin, clear or cloudy, and odorless.
  - Look for any abnormal vaginal discharge: watery, bubbly, foul or “fishy” smelling, “cheesy” white or gray. Take a sample of any vaginal discharge for pH, saline or KOH wet mounts and, if possible, for a Gram’s stain (if laboratory facilities available).
- Look at the cervix and cervical opening (os):
  - The cervical os of a nulliparous woman is small and round or oval. The os of a parous woman is usually a horizontal slit, but may be irregular and open.
  - Note the color of the cervix. The surface should be smooth and pink, with the color evenly distributed. The area of the cervix where the color changes from pink to red is the T-zone, which is usually just inside the external cervical os.
  - Note the position of the cervix (anterior or posterior); if there are polyps, nodules, cysts or any erosion or shiny red tissue around the os (ectropion); or if there is bleeding or discharge containing pus. Normal cervical secretions should be clear or cream-colored and odorless.
  - The cervix should not bleed easily when gently touched with a cotton-tipped swab.
  - If there is mucopus or if the cervix bleeds easily, a specimen should be obtained for Gram’s stain and tests for gonorrhea and chlamydia (if laboratory facilities are available).
- After obtaining any specimens, unlock the speculum blades by keeping your thumb on the lever and loosening the thumbscrew(s). While keeping the blades partly separated, rotate the speculum 90°.

Remove it slowly so that you can look at the anterior and posterior vaginal walls (**Figure G-19**).

**Figure G-19. Removing the Speculum**



As the speculum is withdrawn, the blades will tend to close. To prevent the blades from closing and pinching the vaginal mucosa or labia, keep your thumb on the lever of the speculum.



To avoid causing discomfort and putting pressure on the urethra, maintain a slight downward pressure on the speculum as you remove it.

- After gently removing the speculum, place it in a 0.5% chlorine solution for 10 minutes for decontamination.

## **BIMANUAL EXAMINATION**

In this section, you will learn:

- How to determine the size, shape, position, consistency and mobility of the uterus
- How to check for pregnancy, uterine abnormalities (e.g., fibroids or double uterus) or uterine tenderness
- How to assess the adnexa (fallopian tubes, ovaries and broad ligaments) for enlargement or tenderness

### **Preparation**

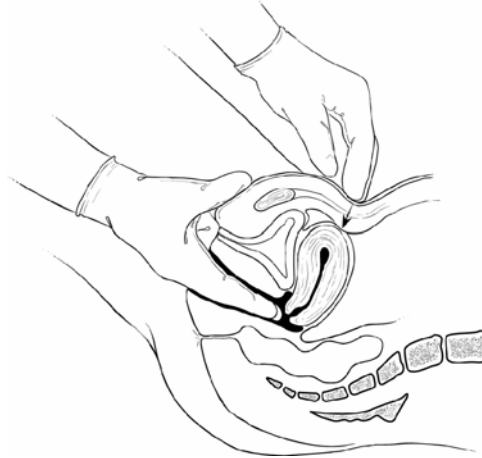
- Once the woman is in position for the speculum examination, no further preparation or positioning is necessary.

### **Performing the Bimanual Examination**

- Wet the index and middle fingers of the pelvic hand with clean water or a small amount of vaginal secretions.
- Separate the labia with two fingers of the abdominal hand and introduce the tips of the index and middle fingers of the pelvic hand slowly and gently into the vagina. While exerting slight downward pressure (away from the bladder) gradually insert your fingers fully while slowly turning your hand palm upward until you touch the cervix. At this point, your thumb should be pointing anteriorly with your ring and little fingers folded into your palm (**Figure G-20**).

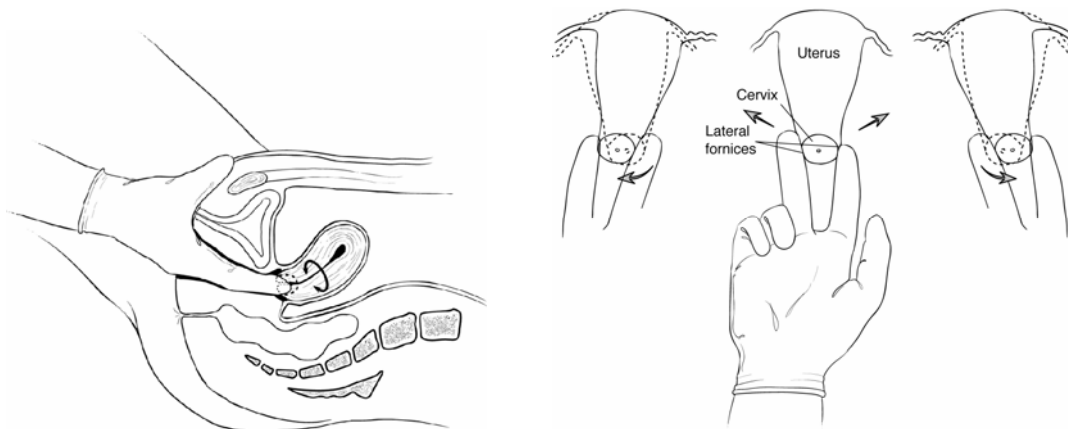
- ✓ For right-handed persons, the hand placed in the vagina usually is the right hand. In these instructions, it is referred to as the pelvic hand. The hand not in the vagina is referred to as the abdominal hand.
- ✓ Avoid placing your thumb on the woman's clitoris because this is uncomfortable for her.

**Figure G-20. Inserting the Fingers into the Vagina**



- Follow the anterior vaginal mucosa until you feel the cervix (**Figure G-20**). Begin gently palpating the cervix.
  - A nonpregnant cervix will feel like the tip of your nose. During pregnancy the cervix is softer, larger and feels like your lip.
  - Feel the size, length and shape of the cervix. Note its position and consistency.
  - The position of the cervix often indicates the position of the corpus of the uterus. A cervix pointing up usually means the uterine body is directed posteriorly (retroverted), while a cervix pointing down usually means an anteriorly directed uterus (anteverted).
  - Move the cervix gently from side to side between your fingers. It should move 1–2 cm in each direction without causing the woman discomfort or pain (**Figures G-21a and b**).

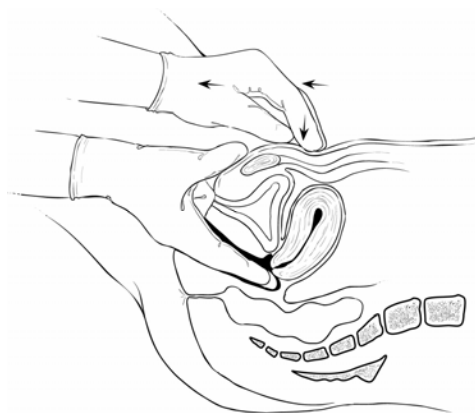
**Figure G-21a and b. Checking Cervical Movement**



If the woman feels pain on cervical motion, it may indicate infection in the uterus or adnexa. Ask the woman to point to the location of the pain.

- To feel the body of the uterus, place the fingers of your pelvic hand in the space behind the cervix with the palm up (**Figure G-22**). Next, place your other hand flat on the abdomen, midway between the umbilicus and the pubic bone.
- Slowly slide your abdominal hand toward the symphysis pubis, pressing downward and forward (toward the uterus) with the flat part (pads) of your fingers. At the same time, push inward and upward with the fingers of the hand in the vagina, trying to trap the uterus between the fingers of your two hands. If the uterus is anteverted, you will feel the fundus between the fingers of your two hands, about 2–4 cm above the level of the pubic bone.

**Figure G-22. Palpation of an Anteriorly Directed Uterus**



The woman may tighten the muscles of her abdomen and buttocks. Asking her to take a deep breath and blow out and relax the muscles of her buttocks will help you to feel the uterus more easily.

If you cannot feel the uterus, it may be either horizontally directed or, more likely, retroverted.

- To check this, you will need to either:
  - move the uterus upward: place the fingers of the pelvic hand under the cervix and gently lift up (anteriorly) (**Figure G-23**), or
  - push down more deeply with the fingers of your abdominal hand.

**Figure G-23. Feeling a Retroverted Uterus**



- If you still cannot find the uterus, move your fingers to each side of the cervix and press inward as far as you can without causing discomfort. Then press downward with your other hand as deeply as possible.

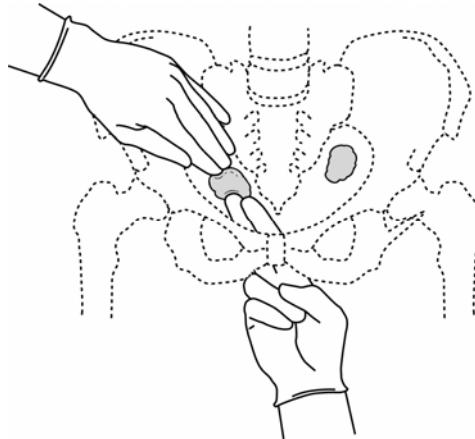


If these maneuvers do not help, it may be necessary to do a rectovaginal examination (see page G-28).

- While palpating the uterus, check for the following:
  - **Size:** The nonpregnant uterus is about 5–8 cm long, 3–5 cm wide and 2 cm thick. If it is enlarged and soft, consider pregnancy.
  - **Shape:** The body of the uterus should be rounded and pear-shaped. If it is irregular, it may indicate the presence of fibroids; if heart-shaped it may indicate a uterine anomaly, such as a double uterus.
  - **Location:** The uterus should be located in the midline. If the top (fundus) is pushed either to the right or left, this suggests possible scar tissue (adhesions), adnexal (ovarian or fallopian tubal) masses or pregnancy (possibly ectopic).
  - **Consistency:** The body should feel smooth and firm. If it is uniformly soft, suspect pregnancy.

- **Mobility:** The uterus should be easy to move anteriorly or posteriorly. If it is fixed (not mobile), suspect adhesions or other problems.
- **Tenderness:** Normally, the uterus is not tender with movement or on palpation. If tenderness is present, suspect infection in the uterine cavity (endometritis).
- Locate the ovaries next. Remember that they usually are located behind and to either side of the uterus.
- To locate the right ovary, move the fingertips of the pelvic hand just under and to the side of the cervix deep in the lateral fornix. Move your abdominal hand to the same side and just lateral to the uterus (**Figure G-24**). Press down (posteriorly) with this hand and reach up (anteriorly) with your vaginal fingers. Gently bring the fingers of both hands together and move them toward the symphysis pubis. You should feel the ovary slip between your fingers. Hold the ovary gently because pressure on a normal ovary can cause pain.

**Figure G-24. Locating the Ovary**



It is often easier to feel the ovary on the same side of the body as the hand that is in the vagina (i.e., right hand in vagina and the right ovary as shown above).



Finding ovaries is a skill that takes much practice to develop. Keep the woman's comfort in mind. If you are just learning, you may not be able to feel the ovaries of every woman. Not being able to feel the ovaries or other adnexal structures generally suggests that they are normal size (approximately 3 cm long, 2 cm wide and 1 cm thick), which is also important to know.

- Record the size, shape, consistency, mobility and tenderness of any masses.
- Repeat the procedure for the other ovary.



A tender adnexal mass in a woman with late or missed menses, irregular bleeding, a positive pregnancy test (if available) or other signs or symptoms of pregnancy suggests an unruptured ectopic pregnancy. This must be evaluated **immediately**, preferably in a hospital with surgical facilities. If you are uncertain, ask another clinician to check your findings.

- Before removing the fingers of your pelvic hand, gently push posteriorly to check for tenderness or masses in the cul-de-sac (space behind the uterus and in front of the rectum).
- If a rectovaginal examination is not necessary, go to **Completing the Examination** (page G-30).

## RECTOVAGINAL EXAMINATION

In this section, you will learn:

- How to verify findings of bimanual examination (e.g., determine the position or size of the uterus or check for masses or tenderness posterior to the uterus)



This examination should be performed only if the findings of bimanual examination are confusing (e.g., inability to palpate the uterus in an obese woman or there is tenderness posterior to the cervix) or if additional information is required.

### **Preparation**

Because a rectovaginal examination is uncomfortable for most women, it should be completed as quickly and gently as possible.

- Explain to the woman what you intend to do and that the examination may make her feel like she has to move her bowels—but she will not.



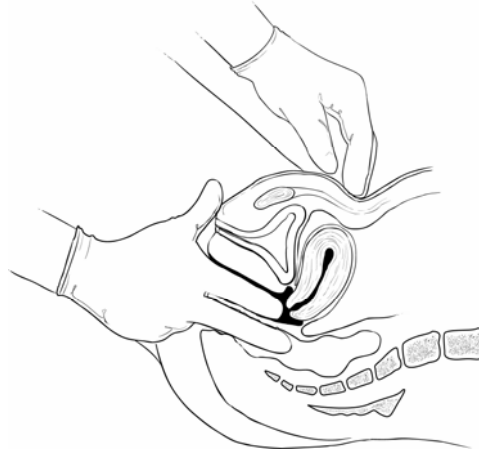
Ask the woman if she has moved her bowels today. If she hasn't, give her the option of doing so before the examination.

- If you suspect the woman has a vaginal infection, you may want to change the glove on your pelvic hand to avoid putting infectious microorganisms from the vagina into the rectum. If you need to change your gloves, before removing them, immerse both gloved hands in 0.5% chlorine solution, then remove them by turning them inside out. If disposing of them, place them in a leakproof container or plastic bag. If reusing the gloves, submerge them in 0.5% chlorine solution for 10 minutes for decontamination.

**Performing a Rectovaginal Examination**

- Slowly insert the middle finger of your pelvic hand into the rectum and your index finger into the vagina (**Figure G-25**). As you do this, ask the client to breathe out through her mouth; this helps relax her rectal muscles (anal sphincter) and helps you feel where to insert your finger. Lubrication of both fingers with water also helps to insert the fingers.

**Figure G-25. Performing a Rectovaginal Examination**



- The tissue between your two fingers is called the rectovaginal septum and measures not more than 2–4 mm (one-quarter of an inch) in thickness along its length.
- Press down firmly and deeply with the abdominal hand just above the pubic bone while the upper (vaginal) finger is pushing anteriorly on the cervix.
- Use the lower (rectal) finger to feel for the posterior surface of the uterus to determine if it is directed toward the rectum. The uterus should feel smooth. Slide the rectal finger upward until the fundus is felt.
- Check for tenderness or masses between the posterior surface of the uterus and the rectum. This could suggest endometriosis.
- When you have completed the rectovaginal examination, remove both fingers slowly.

## COMPLETING THE EXAMINATION

- After completing the examination, immerse both gloved hands in 0.5% chlorine solution. Remove the gloves by turning inside out.
- If disposing of gloves, place them in a leakproof container or plastic bag.
- If reusing the gloves, submerge them in the 0.5% chlorine solution for 10 minutes for decontamination.



If a rectovaginal examination was performed, the gloves **cannot** be reused. Thus, after immersing both gloved hands in 0.5% chlorine solution, remove them and place in a leakproof container or plastic bag.

- Wash your hands thoroughly with soap and water and dry them with a clean, dry cloth or allow them to air dry.
- Ask the woman to move toward the head of the table and help her into a sitting position.
- When lubrication is used for the bimanual or rectovaginal examinations, or if the woman has her menstrual period or discharge, offer her a tissue to wipe off her external genitalia and rectum before she dresses. Show her where to dispose of the tissue.
- After she is dressed, if the examination was normal, tell the woman that everything is normal and healthy, and when she should return for a checkup. If there were abnormal findings, discuss these with her and tell her what, if anything, needs to be done.
- If a rubber sheet was used, wipe with 0.5% chlorine solution.
- Record your findings.

### **Recording the Findings**

After performing the pelvic examination, write the findings in the woman's record. An example of the findings from a normal examination is shown below.

Abdomen and Groin Examination	Appeared normal. No scars, hernial defects or masses. No tenderness during palpation and no groin lesions.
External Genital Examination	Normal appearance. Bartholin's and Skene's glands normal. Good vaginal support.
Speculum Examination	
Vagina	Clear with no lesions.
Cervix	Normal. (Note if any specimens were taken for Gram's stain or culture.)

## *Performing Breast and Pelvic Examinations*

### Bimanual Examination

Uterus	Normal size, shape and consistency. Anteriorly directed, midline, freely mobile and nontender.
Ovaries	Palpably normal.
Adnexa	No masses or tenderness.

Rectovaginal Examination	Confirms bimanual examination.
--------------------------	--------------------------------

## **MOST COMMONLY ASKED QUESTIONS ABOUT PELVIC EXAMINATIONS**

<b>What is a pelvic examination?</b>	A pelvic examination is looking at the labia, clitoris and pubic area and checking the inner female organs including the vagina, cervix, uterus and ovaries.
<b>Why do I need a pelvic examination?</b>	The pelvic examination ensures that your pelvic organs are healthy. It also helps your healthcare provider find any medical conditions, such as infections or abnormalities in the cervix or vagina, which could become serious if not treated. Many healthcare providers recommend that you have your first pelvic examination when you become sexually active or by 18 years of age.
<b>Will the pelvic examination hurt?</b>	The pelvic examination will not be painful. Many women describe their experience as a feeling of crowding or fullness in the vagina; however, there should be no pain. Sometimes a woman will feel discomfort, especially if she is not relaxed. Women who have not had a baby or who have an infection may feel some pain.
<b>What will the pelvic examination feel like?</b>	You will feel gloved fingers touching the outside of your genitals. During the bimanual examination, you will feel two fingers in the vagina and the other hand on the abdomen gently pressing the tissue between the two hands. At one point during the examination, the healthcare provider will insert an instrument called a speculum into the vagina. Healthcare providers sometimes will complete the examination by doing a rectal examination by placing one finger in the rectum and one finger in the vagina. Doing this examination allows the healthcare provider to feel higher and deeper in the pelvis to ensure that everything is normal.
<b>I feel scared to have a pelvic examination. Do other women feel this way?</b>	It is normal to feel uncomfortable, embarrassed or scared during an examination. Many women complain that the most uncomfortable part of the examination is that they feel embarrassed to show their genitals to a healthcare provider. It may help to remember that your healthcare provider is highly trained in performing these exams.

- Do I have to take off all of my clothes?** You will be asked to remove your undergarments and other clothing as needed. You can undress in privacy and cover yourself with a cloth sheet or drape, if it is available, before your healthcare provider comes in for the examination.
- What is the most common position for the pelvic examination?** The most common position is lying on your back with your feet resting in stirrups; however, various positions can be used for a pelvic examination. You will be asked to move your buttocks down to the end of the table and let your knees fall wide apart. The reason for this position and the stirrups is to provide the healthcare provider enough access to the genital area.
- Can I see what is happening during the pelvic examination?** Ask your healthcare provider if you can watch the examination by holding a mirror in your hand. Many healthcare providers are happy to show women their external and internal genital organs.
- How long will the pelvic examination take?** Usually, the whole examination takes no more than 5 minutes. Although many women find the examination uncomfortable, it is important to your health now and in the future. After the first examination, most women find that it was not as uncomfortable as they might have imagined.
- Can my healthcare provider tell if my cervix is healthy?** A Pap test or Pap smear is a screening test that helps healthcare providers find any abnormal changes in the cells of the cervix. A Pap test is done to find changes before they can become cancer. The Pap smear includes taking a sample of cells by wiping or scraping a small wooden stick (similar to a tongue depressor) over the cervix. During the Pap smear you will feel a swab being wiped across the cervix; this feels somewhat scratchy, but is not painful. If your Pap test is abnormal, do not be alarmed. Many women incorrectly believe an abnormal Pap test means they have cancer.
- An alternative to a Pap smear is called visual inspection with dilute acetic acid. With this test, your healthcare provider looks at your cervix after it has been wiped with a small amount of vinegar solution. Putting this solution on the cervix does not hurt. It helps your healthcare provider immediately see if your cervix is healthy because abnormal cells appear white after being washed with vinegar.

## **REFERENCES**

Bates B. 1983. *A Guide to Physical Examination*, Third edition. J.B. Lippincott Company: Philadelphia, Pennsylvania.

Burns AA et al. 1997. *Where Women Have No Doctor: A Health Guide for Women*. The Hesperian Foundation: Berkeley, California.

*Performing Breast and Pelvic Examinations*

*Do It Yourself: Monthly Breast Self-Exam.* 1987. Wyeth-Ayerst Laboratories: Philadelphia, Pennsylvania.

*Dorland's Illustrated Medical Dictionary*, Twenty-eighth edition. 1994. W.B. Saunders Company: Philadelphia, Pennsylvania.

International Planned Parenthood Federation (IPPF). 1997. *Family Planning Handbook for Health Professionals: The Sexual and Reproductive Health Approach*. International Planned Parenthood Federation: London.

Mishell Jr DR et al. 1997. *Comprehensive Gynecology*, Third edition. Mosby-Year Book, Inc.: St. Louis, Missouri.

Seidel HM et al. 1995. *Mosby's Guide to Physical Examination*. Third edition. Mosby: St. Louis, Missouri.

Spence WR. 1994. *Breast Care: The Good News*. Health Edco: Waco, Texas.

Thomas CL (ed). 1997. *Taber's Cyclopedic Medical Dictionary*, Eighteenth edition. F.A. Davis Company: Philadelphia, Pennsylvania.

Tietjen L, W Cronin and N McIntosh. 1992. *Infection Prevention for Family Planning Service Programs: A Problem-Solving Reference Manual*. JHPIEGO Corporation: Baltimore, Maryland.

## LEARNING GUIDE FOR BREAST EXAMINATIONS

(To be completed by **Participants**)

Rate the performance of each step or task observed using the following rating scale:

- 1 Needs Improvement:** Step or task not performed correctly or out of sequence (if necessary) or is omitted
- 2 Competently Performed:** Step or task performed correctly in proper sequence (if necessary) but participant does not progress from step to step efficiently
- 3 Proficiently Performed:** Step or task efficiently and precisely performed in the proper sequence (if necessary)

LEARNING GUIDE FOR BREAST EXAMINATIONS					
STEP/TASK	CASES				
<b>GETTING READY</b>					
1. Greet the woman respectfully and with kindness.					
2. Tell her you are going to examine her breasts.					
3. Ask the woman to undress from her waist up. Have her sit on the examining table with her arms at her sides.					
4. Wash your hands thoroughly with soap and water and dry them with a clean, dry cloth or allow them to air dry. If there are open sores or nipple discharge, put new examination or high-level disinfected surgical gloves on both hands.					
<b>BREAST EXAMINATION</b>					
1. Look at the breasts and note any differences in: <ul style="list-style-type: none"> <li>• shape</li> <li>• size</li> <li>• nipple or skin puckering</li> <li>• dimpling</li> </ul> Check for any swelling, increased warmth or tenderness in either breast.					
2. Look at the nipples and note size, shape and direction in which they point. Check for rashes or sores and nipple discharge.					
3. Ask the woman to raise her arms over her head and look at her breasts. Note any differences. Have the woman press her hands on her hips and look at the breasts again.					
4. Ask her to lean forward to see if her breasts hang evenly.					
5. Have her lie down on the examining table.					
6. Place a pillow under her left shoulder. Place the woman's left arm over her head.					
7. Look at the left breast and note any differences from the right breast. Check for any puckering or dimpling.					
8. Using the pads of your three middle fingers, palpate the entire breast, starting at the top outermost edge of the breast, using the spiral technique. Note any lumps or tenderness.					
9. Use the thumb and index finger to gently squeeze the nipple. Note any clear, milky or bloody discharge.					
10. Repeat these steps for the right breast. If necessary, repeat this procedure with the woman sitting up and with her arms at her sides.					

*Performing Breast and Pelvic Examinations*

<b>LEARNING GUIDE FOR BREAST EXAMINATIONS</b>					
<b>STEP/TASK</b>	<b>CASES</b>				
11. Have the woman sit up and raise her arm to shoulder level. Palpate the tail of the breast by pressing along the outside edge of the left pectoral muscle while gradually moving your fingers up into the axilla. Check for enlarged lymph nodes or tenderness.					
12. Repeat this step for the right side.					
13. After completing the examination, have the woman cover herself. Explain any abnormal findings and what needs to be done. If the examination is normal, tell the woman everything is normal and healthy and when she should return for a repeat examination.					
14. Show the woman how to perform a breast self-examination.					

## CHECKLIST FOR BREAST EXAMINATIONS

(To be used by the **Trainer**)

Place a “✓” in case box if step/task is performed **satisfactorily**, and “X” if it is **not** performed **satisfactorily**, or N/O if not observed.

**Satisfactory:** Performs the step or task according to the standard procedure or guidelines

**Unsatisfactory:** Unable to perform the step or task according to the standard procedure or guidelines

**Not Observed:** Step or task or skill not performed by participant during evaluation by clinical trainer

CHECKLIST FOR BREAST EXAMINATIONS					
STEP/TASK	CASES				
<b>GETTING READY</b>					
1. Greet the woman respectfully and with kindness.					
2. Tell the woman you are going to examine her breasts.					
3. Ask the woman to undress from her waist up. Have her sit on the examining table with her arms at her sides.					
4. Wash hands thoroughly and dry them. If necessary, put on new examination or high-level disinfected surgical gloves on both hands.					
<b>SKILL/ACTIVITY PERFORMED SATISFACTORILY</b>					
<b>BREAST EXAMINATION</b>					
1. Look at the breasts and note any differences in: <ul style="list-style-type: none"> <li>• shape</li> <li>• size</li> <li>• nipple or skin puckering</li> <li>• dimpling</li> </ul> Check for swelling, increased warmth or tenderness in either breast.					
2. Look at the nipples and note size, shape and direction in which they point. Check for rashes or sores and nipple discharge.					
3. Look at breasts while woman has hands over her head and presses her hands on her hips. Check to see if breasts hang evenly.					
4. Have her lie down on the examining table.					
5. Look at the left breast and note any differences from the right breast.					
6. Place pillow under woman’s left shoulder and place her arm over her head.					
7. Palpate the entire breast using the spiral technique. Note any lumps or tenderness.					
8. Squeeze the nipple gently and note any discharge.					
9. Repeat these steps for the right breast. If necessary, repeat this procedure with the woman sitting up and with her arms at her sides.					
10. Have the woman sit up and raise her arm. Palpate the tail of the breast and check for enlarged lymph nodes or tenderness.					
11. Repeat this procedure for the right side.					

*Performing Breast and Pelvic Examinations*

<b>CHECKLIST FOR BREAST EXAMINATIONS</b>					
<b>STEP/TASK</b>	<b>CASES</b>				
12. After completing the examination, have woman cover herself. Explain any abnormal findings and what needs to be done. If the examination is normal, tell the woman everything is normal and healthy and when she should return for a repeat examination.					
13. Show the woman how to perform a breast self-examination.					
<b>SKILL/ACTIVITY PERFORMED SATISFACTORILY</b>					

## LEARNING GUIDE FOR PELVIC EXAMINATIONS

(To be completed by **Participants**)

Rate the performance of each step or task observed using the following rating scale:

- 1 Needs Improvement:** Step or task not performed correctly or out of sequence (if necessary) or is omitted
- 2 Competently Performed:** Step or task performed correctly in proper sequence (if necessary) but participant does not progress from step to step efficiently
- 3 Proficiently Performed:** Step or task efficiently and precisely performed in the proper sequence (if necessary)

LEARNING GUIDE FOR PELVIC EXAMINATIONS					
STEP/TASK	CASES				
<b>GETTING READY</b>					
1. Explain why the examination is being done and describe the steps in the examination.					
2. Ask the woman to empty her bladder and wash and rinse her abdominal and genital area.					
3. Check that the instruments and supplies are available.					
4. Ask the woman to undress and help her onto the examining table.					
5. Wash your hands thoroughly with soap and water and dry them with a clean, dry cloth or allow them to air dry.					
<b>LOWER ABDOMINAL AND GROIN EXAMINATION</b>					
1. Ask the woman to lie down on the examining table with her arms at her sides.					
2. Expose the entire abdomen.					
3. Note any swelling or bulges in the abdomen. Note the location and shape of the umbilicus.					
4. Inspect the abdomen for abnormal coloring, scars, stretch marks or rashes and lesions.					
5. Using light pressure with the pads of your fingers, palpate all areas of the abdomen. Identify any masses, areas of tenderness or muscular resistance. Record your findings.					
6. Using deeper pressure, determine size, shape, consistency, tenderness, mobility and movement of any masses. Record any masses and areas of tenderness.					
7. Identify any tender areas. If abnormal tenderness is present, check for rebound tenderness.					
8. If open sores are present on groin, put new examination or high-level disinfected surgical gloves on both hands before examining groin. Palpate both groin areas for bumps, buboes or swelling.					
<b>EXTERNAL GENITAL EXAMINATION</b>					
1. Ask the woman to place her heels in the stirrups. If there are no stirrups, help her place her feet on the outside edges of the end of the table. Drape the woman.					
2. Wash your hands thoroughly with soap and water and dry them with a clean, dry cloth or allow them to air dry.					

*Performing Breast and Pelvic Examinations*

LEARNING GUIDE FOR PELVIC EXAMINATIONS					
STEP/TASK	CASES				
3. Turn on light and direct it toward genital area.					
4. Put new examination or high-level disinfected gloves on both hands.					
5. Touch the inside of her thigh before touching any of the genital area.					
6. Inspect the labia, clitoris and perineum.					
7. Separating the labia majora with two fingers, check the labia minora, clitoris, urethral opening and vaginal opening.					
8. Palpate the labia minora. Look for swelling, discharge, tenderness, ulcers and fistulas. Feel for any irregularities or nodules.					
9. Check the Skene's glands for discharge and tenderness. With the palm facing upward, insert the index finger into the vagina and gently push upward against the urethra and milk the gland on each side and then directly on the urethra. (If discharge is present, take a smear for Gram's stain and tests for gonorrhea and chlamydia, if laboratory facilities are available.)					
10. Check the Bartholin's glands for discharge and tenderness. Insert index finger into vagina at lower edge of opening and feel at base of each of the labia majora. Using your finger and thumb, palpate each side for any swelling or tenderness. (If discharge is present, take a smear for Gram's stain and tests for gonorrhea and chlamydia, if laboratory facilities are available.)					
11. Ask the woman to bear down while you hold the labia open. Check for any bulging of the anterior or posterior vaginal walls.					
12. Look at the perineum. Check for any scarring, lesions, inflammation or cracks in the skin.					
<b>SPECULUM EXAMINATION</b>					
1. Select a bivalve speculum and show it to the woman. Explain what you are going to do.					
2. Insert the speculum fully and open the blades. Look at the vaginal walls and note any inflammation, ulcers or sores. Check for any discharge.					
3. Look at the cervix and os and note the color, position, smoothness or discharge. If the cervix bleeds easily or there is mucopus, obtain a specimen for Gram's stain and tests for gonorrhea and chlamydia, if laboratory facilities are available.					
4. Remove the speculum.					
5. Place the speculum in 0.5% chlorine solution for decontamination.					
<b>BIMANUAL EXAMINATION</b>					
1. Wet the index and middle fingers of the hand that will be inserted in the vagina (pelvic hand) with clean water or vaginal secretions.					
2. Separate the labia with two finger of the abdominal hand and insert the tips of the index and middle fingers of the pelvic hand into the vagina.					
3. While exerting pressure downward, wait for the perineal muscles to relax. Gradually insert fingers fully or until the cervix is touched.					
4. Turn your palm upward and follow the anterior vaginal mucosa until you feel the cervix.					
5. Feel the length, size and shape of the cervix. Note its position and consistency.					
6. Move the cervix gently from side to side between your fingers. Note whether the woman feels pain.					

LEARNING GUIDE FOR PELVIC EXAMINATIONS					
STEP/TASK	CASES				
7. With the palm up, place the fingers of your pelvic hand in the space behind the cervix to feel the body of the uterus.					
8. Place your other hand flat on the abdomen, midway between the umbilicus and the pubic bone.					
9. Slowly slide your abdominal hand toward the symphysis pubis, pressing downward and forward with the pads of your fingers. At the same time, push inward and upward with the fingers of the pelvic hand, trying to trap the uterus between your hands. If you cannot feel the uterus, check whether it is retroverted.					
10. Palpate the uterus and check for: <ul style="list-style-type: none"> <li>• Size</li> <li>• Shape</li> <li>• Location</li> <li>• Consistency</li> <li>• Mobility</li> <li>• Tenderness</li> </ul>					
11. Locate an ovary by placing the fingers of the pelvic hand inside the vagina with the tips in the lateral fornix. Move your abdominal hand to the same side and lateral to the uterus. Press down with the abdominal hand and reach up with the fingers of your pelvic hand. Gently bring the fingers of both hands together and move them toward the symphysis pubis.					
12. Determine size, consistency and mobility of ovary.					
13. Repeat this procedure for the other ovary.					
14. Check the size, shape consistency, mobility and tenderness of any masses in the adnexa.					
<b>RECTOVAGINAL EXAMINATION</b>					
1. Explain to the woman what you are going to do.					
2. If you need to change your gloves, immerse both hands in 0.5% chlorine solution, then remove them by turning them inside out. If disposing of them, place them in a leakproof container or plastic bag. If reusing the gloves, submerge them in 0.5% chlorine solution for decontamination.					
3. Slowly insert the middle finger of the pelvic into the rectum and your index finger into the vagina. Ask the woman to exhale to help her relax.					
4. Press down firmly and deeply with the abdominal hand above the pubic bone while the vaginal and rectal fingers are pushing anteriorly on the cervix.					
5. Feel the surface of the uterus and check to see if it is smooth.					
6. Check for tenderness or masses between the uterus and rectum.					
7. After you have completed the examination, remove both fingers slowly.					
8. Immerse both gloved hands in 0.5% chlorine solution, remove gloves by turning inside out and dispose of them in a leakproof container or plastic bag.					
<b>COMPLETING THE PELVIC EXAMINATION</b>					
1. If rectovaginal examination was not performed, immerse both gloved hands in 0.5% chlorine solution, then remove gloves by turning them inside out. <ul style="list-style-type: none"> <li>• If disposing of gloves, place them in a leakproof container.</li> <li>• If reusing the gloves, submerge them in 0.5% chlorine solution for decontamination.</li> </ul>					

*Performing Breast and Pelvic Examinations*

LEARNING GUIDE FOR PELVIC EXAMINATIONS					
STEP/TASK	CASES				
2. Wash your hands thoroughly with soap and water and dry them on a clean, dry cloth or allow them to air dry.					
3. Help the woman to sit up on the examining table and ask her to get dressed.					
4. After the woman is dressed, discuss any abnormal findings and what, if anything, she needs to do. If the examination was normal, tell her that everything is normal and healthy.					

## CHECKLIST FOR PELVIC EXAMINATIONS

(To be used by the **Trainer**)

Place a “✓” in case box if step/task is performed **satisfactorily**, and “X” if it is **not** performed **satisfactorily**, or N/O if not observed.

**Satisfactory:** Performs the step or task according to the standard procedure or guidelines

**Unsatisfactory:** Unable to perform the step or task according to the standard procedure or guidelines

**Not Observed:** Step or task or skill not performed by participant during evaluation by clinical trainer

CHECKLIST FOR PELVIC EXAMINATIONS					
STEP/TASK	CASES				
<b>GETTING READY</b>					
1. Explain why the examination is being done and describe the steps in the examination.					
2. Ask the woman to empty her bladder and wash and rinse her abdominal and genital area.					
3. Check that the instruments and supplies are available.					
4. Ask the woman to undress and help her onto the examining table.					
5. Wash hands thoroughly with soap and water and dry them.					
<b>SKILL/ACTIVITY PERFORMED SATISFACTORILY</b>					
<b>LOWER ABDOMINAL AND GROIN EXAMINATION</b>					
1. Ask the woman to lie down on the examining table.					
2. Look at the abdomen for abnormal coloring, scars, stretch marks or rashes and lesions.					
3. Palpate all areas of the abdomen using a light pressure. Then, palpate the abdomen using a deeper pressure.					
4. Identify any tender areas and check for rebound tenderness.					
5. Put new examination or high-level disinfected surgical gloves on both hands if sores are present on groin. Palpate both groin areas for bumps, buboes or swelling.					
<b>SKILL/ACTIVITY PERFORMED SATISFACTORILY</b>					
<b>EXTERNAL GENITAL EXAMINATION</b>					
1. Position and drape woman.					
2. Wash hands thoroughly and dry them. Put new examination or high-level disinfected surgical gloves on both hands.					
3. Inspect external labia, clitoris and perineum.					
4. Check the labia minora, clitoris, urethral opening and vaginal opening.					
5. Check the Skene’s glands and urethra and take smears, if discharge is present.					
6. Check the Bartholin’s glands and take smears, if discharge is present.					
7. Ask the woman to bear down while holding the labia open. Check for any bulging of the anterior or posterior vaginal walls.					
8. Look at the perineum.					
<b>SKILL/ACTIVITY PERFORMED SATISFACTORILY</b>					

*Performing Breast and Pelvic Examinations*

<b>CHECKLIST FOR PELVIC EXAMINATIONS</b>					
<b>STEP/TASK</b>	<b>CASES</b>				
<b>SPECULUM EXAMINATION</b>					
1. Insert the speculum fully and open the blades. Look at the vaginal walls and note any inflammation, ulcers or sores. Check for any discharge.					
2. Look at the cervix and os and note the color, position, smoothness or discharge. If the cervix bleeds easily or there is mucopus, obtain a specimen for tests.					
3. Remove the speculum and place in 0.5% chlorine solution for decontamination.					
<b>SKILL/ACTIVITY PERFORMED SATISFACTORILY</b>					
<b>BIMANUAL EXAMINATION</b>					
1. Separate the labia with two fingers of the abdominal hand and insert the tips of the index and middle fingers of the pelvic hand into the vagina.					
2. Gradually insert fingers fully or until the cervix is touched.					
3. Palpate the uterus and check for: <ul style="list-style-type: none"> <li>• Size</li> <li>• Shape</li> <li>• Location</li> <li>• Consistency</li> <li>• Mobility</li> <li>• Tenderness</li> </ul>					
4. Locate ovaries and determine size and consistency.					
5. Check the size, shape consistency, mobility and tenderness of any masses in the adnexa.					
<b>SKILL/ACTIVITY PERFORMED SATISFACTORILY</b>					
<b>RECTOVAGINAL EXAMINATION</b>					
1. If changing gloves, immerse both hands in 0.5% chlorine solution, then remove them by turning them inside out. <ul style="list-style-type: none"> <li>• If disposing of gloves, place them in a leakproof container.</li> <li>• If reusing the gloves, submerge them in 0.5% chlorine solution for decontamination.</li> </ul>					
2. Slowly insert middle finger of the pelvic into the rectum and index finger into the vagina.					
3. Check for tenderness or masses between the uterus and rectum.					
4. Immerse both gloved hands in 0.5% chlorine solution, remove gloves by turning them inside out and dispose of them in a leakproof container.					
<b>SKILL/ACTIVITY PERFORMED SATISFACTORILY</b>					
<b>COMPLETING THE PELVIC EXAMINATION</b>					
1. If rectovaginal examination was not performed, immerse both gloved hands in 0.5% chlorine solution, then remove gloves by turning them inside out. <ul style="list-style-type: none"> <li>• If disposing of gloves, place them in a leakproof container.</li> <li>• If reusing the gloves, submerge them in 0.5% chlorine solution for decontamination.</li> </ul>					
2. Wash hands thoroughly and dry them.					
3. Help the woman to sit up on the examining table and ask her to get dressed.					

<b>CHECKLIST FOR PELVIC EXAMINATIONS</b>					
<b>STEP/TASK</b>		<b>CASES</b>			
4. Discuss any abnormal findings and what, if anything, she needs to do. If the examination was normal, tell her that everything is normal and healthy.					
<b>SKILL/ACTIVITY PERFORMED SATISFACTORILY</b>					



## APPENDIX H

# PERCEIVED BARRIERS TO PROVIDING CERVICAL CANCER PREVENTION SERVICES<sup>1</sup>

The following were listed in a PATH survey regarding the main barriers to providing CIN treatment in developing countries<sup>2</sup>:

- Lack of a comprehensive screening program: (66%)
- Cost and unavailability of equipment: (57%)
- Inability to followup women: (54%)
- Lack of trained personnel: (48%)
- Inability to identify women with early, treatable disease: (34%)
- Women's resistance to treatment: (15%)
- Other barriers<sup>3</sup>: (19%)

Regionally, slight differences were noted in these results.

A brief discussion of each barrier and of potential solutions is presented below.

## BARRIERS AND POTENTIAL SOLUTIONS

### **Lack of a Comprehensive Screening Program**

Survey results indicated that in all regions, screening largely occurs opportunistically rather than as part of an integrated program. Where cytology (Pap smear) screening is already in place, respondents expressed concern about its quality, and specifically, about high rates of false-negative results. Clearly, establishing widespread, reliable screening is essential to reducing cervical cancer morbidity and mortality. Simple, appropriate screening approaches for low-resource settings that can be paired with outpatient treatment methods also should be identified.

---

<sup>1</sup> Adapted from: Bishop A et al. 1995. *Cervical Dysplasia Treatment in Developing Countries: A Situation Analysis*. Program for Appropriate Technology in Health (PATH): Seattle, Washington.

<sup>2</sup> Number of responses: 97.

<sup>3</sup> Other barriers included: cost of travel to hospital; treatment affordability to patients; lack of patient/public education; lack of political will; insufficient equipment, supplies and facilities for the large number of women needed treatment; high false-negative rate of Pap smears; crowded conditions; and long waiting time for diagnosis.

**Cost and Availability of Equipment**

Since the survey found that clinicians still rely heavily on cone biopsy and hysterectomy, even to treat low-grade lesions, the reasons were explored for why nearly 60% of respondents indicated that cost of equipment was a key barrier to treatment. Survey results revealed that equipment prices varied widely among countries and presumably depended on local availability of equipment and supplies. Still, investing in lower-cost outpatient methods to treat preinvasive conditions is likely to lead to considerable savings because the equipment lasts for many years and the incidence of advanced cases should decrease, thus reducing the demand for more expensive therapy. Finally, survival rates will be much greater, resulting in a lower cost per Discounted Health Life Year (DHLY) gained.<sup>4</sup>

Obtaining supplies for some treatment methods also is difficult.

**Inability to Followup Women**

Referral and followup systems are essential to developing an effective cervical cancer screening and treatment program. A test and treat approach could reduce the number of clinic visits required for evaluation and treatment, which can take many weeks (and is also perceived as a barrier to care). Estimates of the percentage of women who actually return for required post-treatment followup varied considerably. Followup rates can be increased, however, if outreach programs are established specifically to encourage women to return for followup care.

**Lack of Trained Personnel**

According to the survey, at present gynecologists rather than other clinicians usually provide treatment in all regions.

Because many countries have a shortage of gynecologists, as well as physicians in general, reliance on them to perform treatment of precancerous lesions probably has hindered efforts to expand cervical cancer screening and treatment beyond urban areas. If mid-level practitioners, such as nurse-midwives, could be trained to perform screening and perhaps simple outpatient treatment such as cryotherapy, coverage could be expanded in many settings. The feasibility of training nurses and midwives to perform screening and treatment, however, depends on local policies regarding healthcare delivery, and should be evaluated within the local context. Still, this approach warrants further exploration wherever feasible.

**Women's Resistance to Treatment**

Only a small proportion of respondents (about 15%) cited women's resistance as an important barrier. Perceived resistance by women, however, may be related to lack of education and available information for women about cervical cancer, which also was mentioned as a barrier by some respondents.

---

<sup>4</sup> DHLY = number of years between the age at which death would have occurred from cervical cancer and the individual's expected age at death, with years gained discounted at 3% each year.

## **AVAILABILITY OF BASIC SUPPLIES AND EQUIPMENT**

Availability of supplies, equipment and trained staff varies among regions. For examples, survey findings suggests that the majority of facilities represented by the respondents are equipped with examining tables, specula, lights and electricity; however, facilities in African countries represented in the survey were not as well-equipped with these items as those in other regions. Most facilities have access to a pathology laboratory. A majority are equipped with local anesthesia and consumable supplies, but some experienced shortages.

Although facilities represented in the survey seem to have basic equipment to provide some type of treatment, respondents still indicated that for the numbers of women requiring treatment, insufficient supplies, facilities and equipment remained a barrier to service delivery. In particular, respondents cited crowded clinic conditions and long waiting time for services and laboratory results as being important deterrents to providing treatment services.

## **SUMMARY**

Data from this survey suggest that in all regions, but particularly in Africa, low-cost, outpatient procedures such as cryotherapy and LEEP are not being used sufficiently. Rather, clinicians still rely heavily on cone biopsy and hysterectomy, even to treat low-grade lesions. This suggests that education of providers to help change their perceptions of the various methods, and ultimately their methods of choice, is crucial. Heavy reliance on inpatient methods also is likely due to limited access to alternative methods and lack of resources to support early detection and treatment of preinvasive conditions. In addition, inability to follow up women was cited as another important barrier; this highlights the need to develop an effective, single-visit cervical cancer screening and treatment program.

Regionally, it appears that countries in Asia, Latin America and the Caribbean may have greater access to cryotherapy and LEEP than African countries, as well as greater capacity to incorporate these methods into their programs. This suggests that strategies for introducing outpatient treatment will probably differ among these regions, and that introduction efforts in Africa, in particular, will need to be carefully considered in the context of limited resources. In all regions, however, introducing outpatient methods and clear guidelines for their use could improve overall quality of care and extend treatment services beyond central facilities, thereby reaching more women who need them.

**REFERENCE**

Bishop A et al. 1995. *Cervical Dysplasia Treatment in Developing Countries: A Situation Analysis*. Program for Appropriate Technology in Health (PATH): Seattle, Washington.

# GLOSSARY

<b>Acetic Acid</b>	A vinegar solution that is applied to cervical tissue to make identification of abnormal tissue easier. The acetic acid interacts with diseased cells, causing epithelial lesions to turn white.
<b>Acetowhite Change</b>	Areas of the transformation zone that become white in color when stained with acetic acid (see <b>Transformation Zone</b> ).
<b>Carcinoma <i>in Situ</i> (CIS)<sup>1</sup></b>	Malignant cell changes in the epithelial tissue that do not go beyond the basement membrane (see <b>HGSIL</b> and <b>LGSIL</b> ).
<b>Cervical Intraepithelial Neoplasia (CIN)</b>	Dysplasia of the basal layers of the squamous epithelium of the cervix (see <b>HGSIL</b> and <b>LGSIL</b> ).
<b>Cervical Stenosis</b>	A narrowing of the cervical canal that may impair fertility.
<b>Cervicography</b>	Technique in which a photograph of the cervix is obtained after application of dilute (3–5%) acetic acid using a specifically designed handheld camera (Cerviscope).
<b>Cold Coagulation</b>	The use of a thermal probe heated to 100°C to destroy abnormal cervical tissue.
<b>Colposcopy</b>	Examination of the vagina and cervix using an instrument that provides magnification to allow direct observation and study of vaginal and cervical cells <i>in vivo</i> .
<b>Columnar Epithelium</b>	Tall, glandular (mucus-secreting) cells that line the endocervix.
<b>Cone Biopsy (also known as Cold Knife Conization)</b>	A surgical procedure to obtain a cone of endocervical tissue by cutting with a cold knife (scalpel) so as to preserve the tissue's cellular characteristics for histopathology.
<b>Cryotherapy</b>	Method of outpatient treatment that uses low temperatures (-60° to -90°C) to freeze and destroy abnormal tissue. Most commonly, a compressed gas (liquid carbon dioxide or nitrous oxide) is used as the coolant.
<b>Cytology</b>	The study of normal and abnormal cells, such as those covering the ecto- and endocervix.

---

<sup>1</sup> CIN I, II, and III and CIS represent grades of dysplasia based on the degree to which the cervical epithelium is replaced by abnormal cells.

<b>Dysplasia</b>	Abnormal cells in the cervical epithelium; it is considered a precursor to carcinoma. Sometimes called CIN depending on which qualification system is used.
<b>Ectocervix (also Exocervix)</b>	External portion of the cervix and os.
<b>Ectropy/Ectropion</b>	A change in the appearance of the cervix caused by increased presence of glandular tissue (columnar cells) on the outer surface of the cervix. (Columnar epithelium is reddish in color, bleeds easily when touched and is friable.) This condition may result from exposure to sex hormones such as the estrogen and progestins in oral contraceptives.
<b>Electrocautery (Electrocoagulation)</b>	The process of using an electrically heated metal probe reaching very high temperatures (>100°C) to destroy abnormal tissue.
<b>Electrode</b>	The terminal of an electric circuit through which electrons pass and, depending on the resistance, become very hot.
<b>Endocervix</b>	Internal portion of the cervix lined by columnar cells.
<b>Friable</b>	Tissue that bleeds easily when touched.
<b>Gynoscope</b>	One version of a low-power (2.5x) magnification device that may be useful in looking at the cervix in conjunction with acetic acid. It is used to facilitate cervical cancer detection and perhaps to guide biopsy and treatment of preinvasive disease.
<b>HGSIL</b>	High-grade squamous intraepithelial lesion ( <b>CIN II, III/CIS</b> ).
<b>LGSIL</b>	Low-grade squamous intraepithelial lesion ( <b>CIN I</b> ).
<b>Lugol's Iodine</b>	An iodine solution that is applied to cervical tissue to make identification of abnormal tissue easier. The iodine interacts with diseased cells, causing epithelial lesions to turn pale yellow while normal tissue stains dark brown or black. It is also known as iodine potassium iodide or IKI solution.
<b>Loop Electrosurgical Excision Procedure (LEEP)</b>	Method of outpatient excisional biopsy and treatment that removes the entire transformation zone using a thin wire electrode charged with a low-voltage, high-frequency alternating current (60 Hz); produces a tissue specimen suitable for histologic analysis in most circumstances.
<b>Papanicolaou (Pap) Smear</b>	The standard approach to cervical cancer screening that relies on cytology. Cervical cells are scraped from the cervix, fixed on a slide and analyzed using a microscope to determine the presence or absence of cancerous or precancerous changes in the cells.

<b>Patulous</b>	Spread apart or open. Usually refers to a portion of the cervix. Probably the result of obstetrical trauma with subsequent scarring and healing.
<b>Squamocolumnar Junction (SCJ)</b>	The point at which endocervical columnar cells meet ectocervical squamous cells on the cervix. This junction is located in the center of the transformation zone and is most vulnerable to abnormal changes in cervical cells.
<b>Squamous Epithelium</b>	Flattened cells that are irregular in shape and cover the external portion of the cervix (ectocervix).
<b>Transformation Zone (T-zone or TZ)</b>	Located on the surface of the cervix, the transformation zone (T-zone) is composed of glandular (columnar) epithelium until the onset of puberty, when the glandular epithelium is gradually replaced by squamous epithelium, similar to the lining of the vagina. Cervical cancer generally originates at the edges of the T-zone.
<b>Visual Inspection (VI)</b>	Naked eye visualization of cervix used to detect abnormal (precancerous) cells.
<b>Visual Inspection with Acetic Acid (VIA)</b>	Naked-eye visualization of the acetic acid-washed cervix (using dilute 3–5% acetic acid) to detect abnormal (precancerous) cells.
<b>Visual Inspection with Acetic Acid and Magnification (VIAM)</b>	Acetic acid-washed cervix examined with low-power (2–6) magnification to detect abnormal (precancerous) cells.



## ADDITIONAL READING

Alliance for Cervical Cancer (ACCP). 2004. *Planning and Implementing Cervical Cancer Prevention and Control Programs: A Manual for Managers*. ACCP.

Association of Reproductive Health Professionals (ARHP). 2001. *Clinical Proceedings: Human Papillomavirus (HPV) and Cervical Cancer*. ARHP: Washington, DC.

Bosch J et al. 2006. HPV Vaccines and Screening in the Prevention of Cervical Cancer [special issue]. *Vaccine* Vol 24, Suppl 3.

Frisch L, FH Milner and DJ Sherris. 1994. Naked-eye inspection of the cervix after acetic acid application may improve the predictive value of negative cytologic screening. *Journal of Family Practice* 39(5): 457–460.

Hanissian J. 1997. Emerging HPV vaccines. *Infections in Medicine* 14(4): 266, 273–275, 300.

Kols A and J Sherris. 2000. *HPV Vaccines: Promises and Challenges*. PATH: Seattle, Washington.

Malloy C, J Sherris and C Herdman. 2000. *HPV DNA Testing: Technical and Programmatic Issues for Cervical Cancer Prevention in Low-Resource Settings*. PATH: Seattle, Washington.

Montz FJ. 1996. Impact of therapy for cervical intraepithelial neoplasia on fertility. *American Journal of Obstetrics and Gynecology* 175: 1129–1136.

Ottaviano M and P La Torre. 1982. Examination of the cervix with the naked eye using acetic acid test. *American Journal of Obstetrics & Gynecology* 143(2): 139–142.

Pisani P. 1998. Personal communication. Cited in: Preventing cervical cancer in low-resource settings. *Outlook* 16(1): 1–8.

Sanghvi H. 1994. Cervical cancer screening in Kenya, in *Issues in Cervical Cancer: Seeking Alternatives to Cytology*. Blumenthal PD et al. (eds). Workshop Proceedings (2–4 March). JHPIEGO: Baltimore, Maryland.

Sankaranarayanan R and P Pisani. 1997. Prevention measures in the third world: Are they practical? in *New Developments in Cervical*

*Cancer Screening and Prevention*. Franco E and J Monsonogo (eds). Blackwell Science Ltd.: Malden, Massachusetts.

Sankaranarayanan R et al. 1998. Visual inspection of the uterine cervix after application of acetic acid in the detection of cervical carcinoma and its precursors. *Cancer* 83: 2150–2156.

Sankaranarayanan R et al. 1997. Visual inspection as a screening test for cervical cancer control in developing countries, in *New Developments in Cervical Cancer Screening and Prevention*. Franco E and J Monsonogo (eds). Blackwell Science Ltd.: Malden, Massachusetts.

Sivanesaratnam V et al. 1999. Problems in management of CIN. *Thai Journal of Obstetrics and Gynaecology* 11(Suppl 1): 27–30.

Slawson DC, JH Bennett and JM Herman. 1992. Are Papanicolaou smears enough? Acetic acid washes of the cervix as adjunctive therapy: A HARNET Study. *Journal of Family Practice* 35(3): 271–277.

Tietjen L, D Bossemeyer and N McIntosh. 2004. *Infection Prevention Guidelines for Healthcare Facilities with Limited Resources*. JHPIEGO: Baltimore, Maryland.

Womak SD et al. 2000. HPV-based cervical cancer in a population at high risk for HIV infection. *International Journal of Cancer* 85: 206–210.



